

# Detail RW1

## Roof-to-Rising-Wall-Transition - Brick Shelf Angle With Standoff Clips (2D)

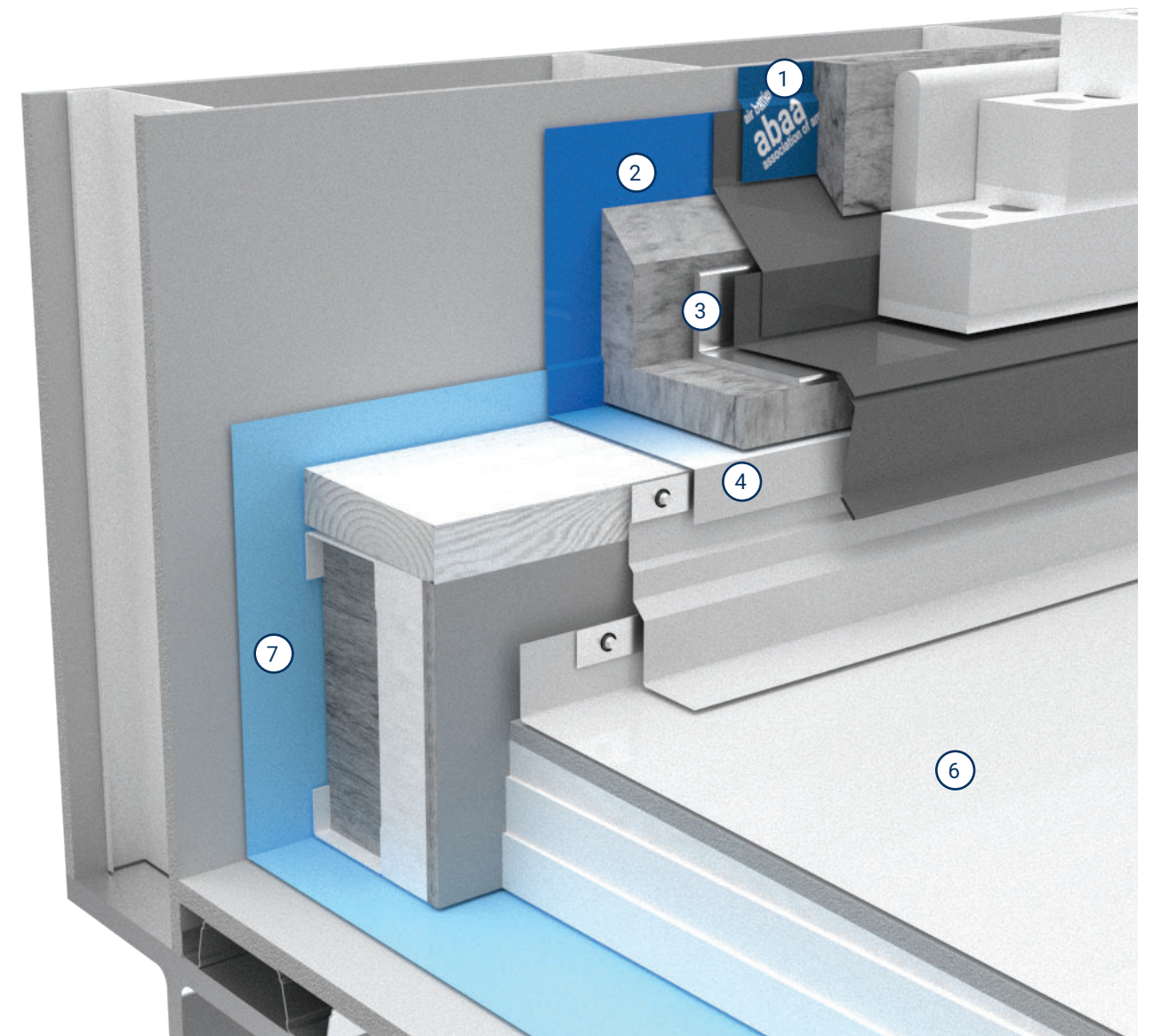
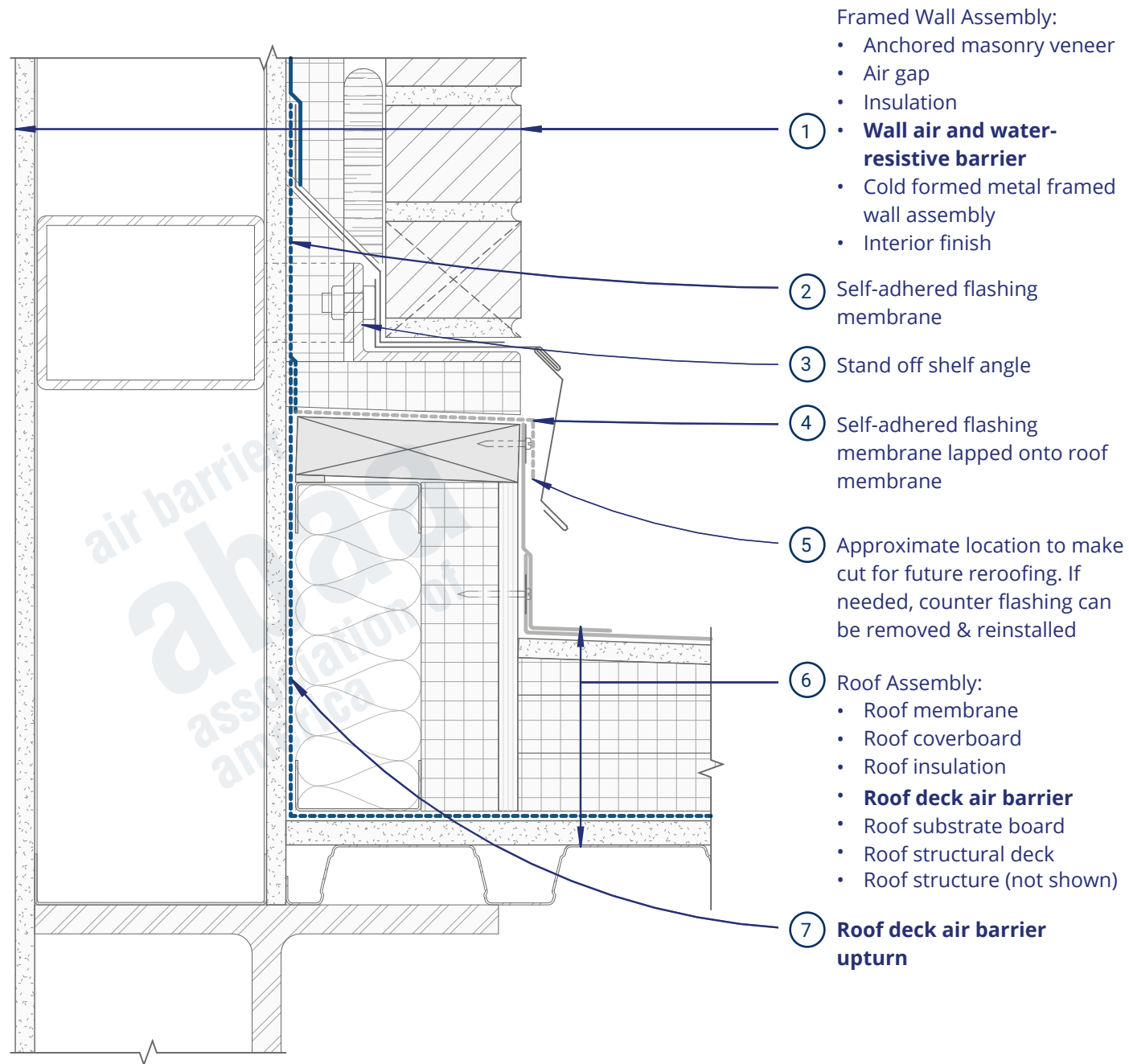

## Roof-to-Rising-Wall-Transition - Brick Shelf Angle With Standoff Clips (2D)