

# Detail RS8

## Rainscreen Wall - Deck Air Barrier Prior to Parapet Extension With Thermal Break (2D)

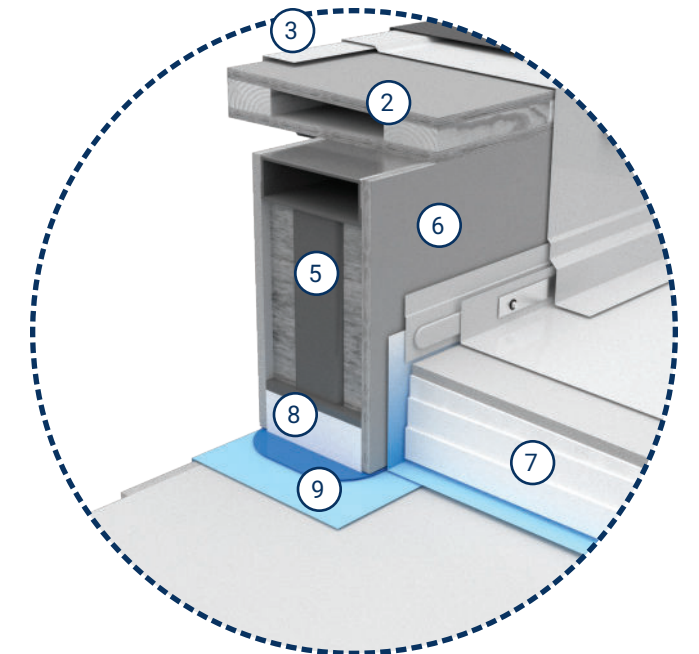

View from Roof

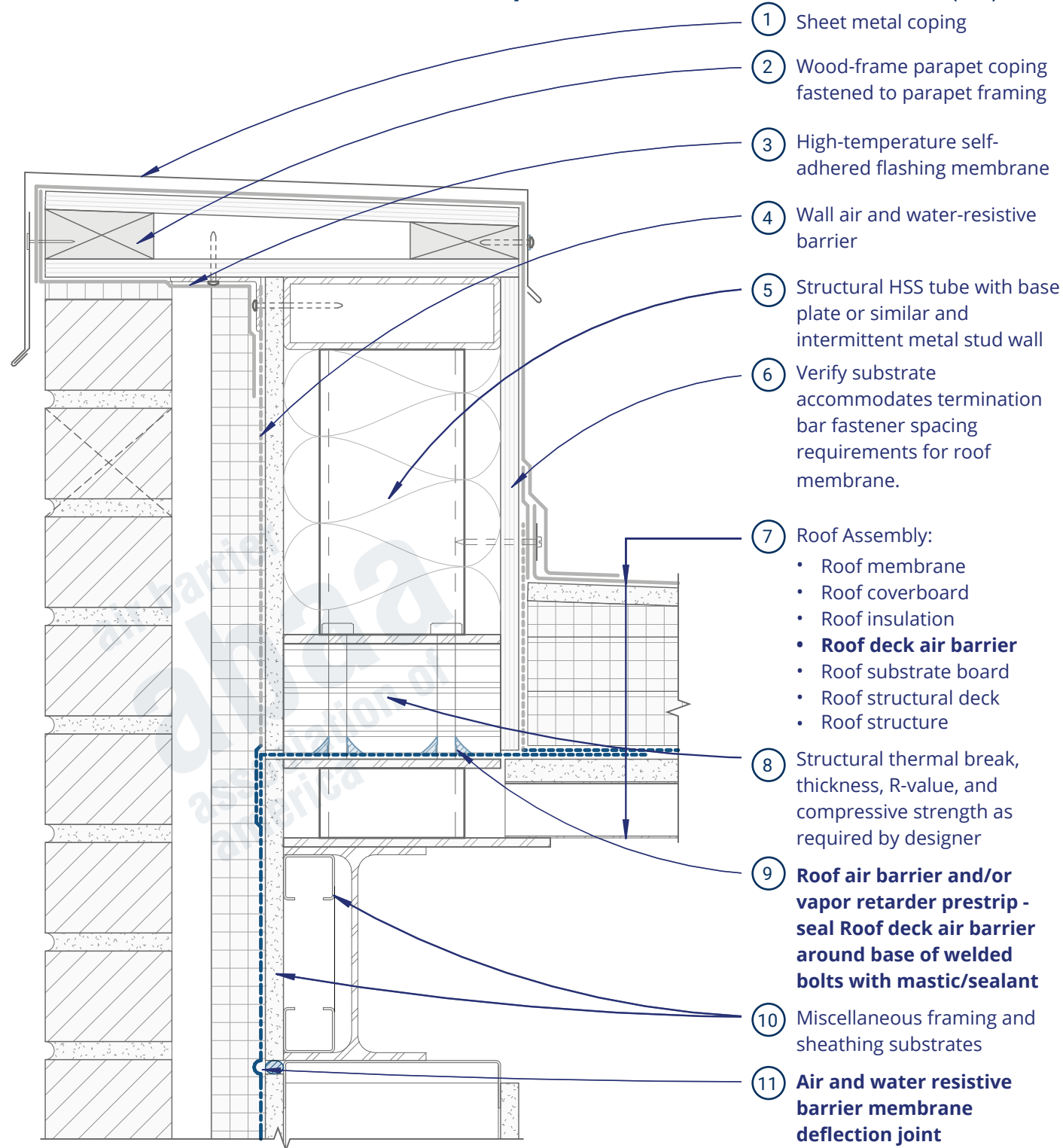
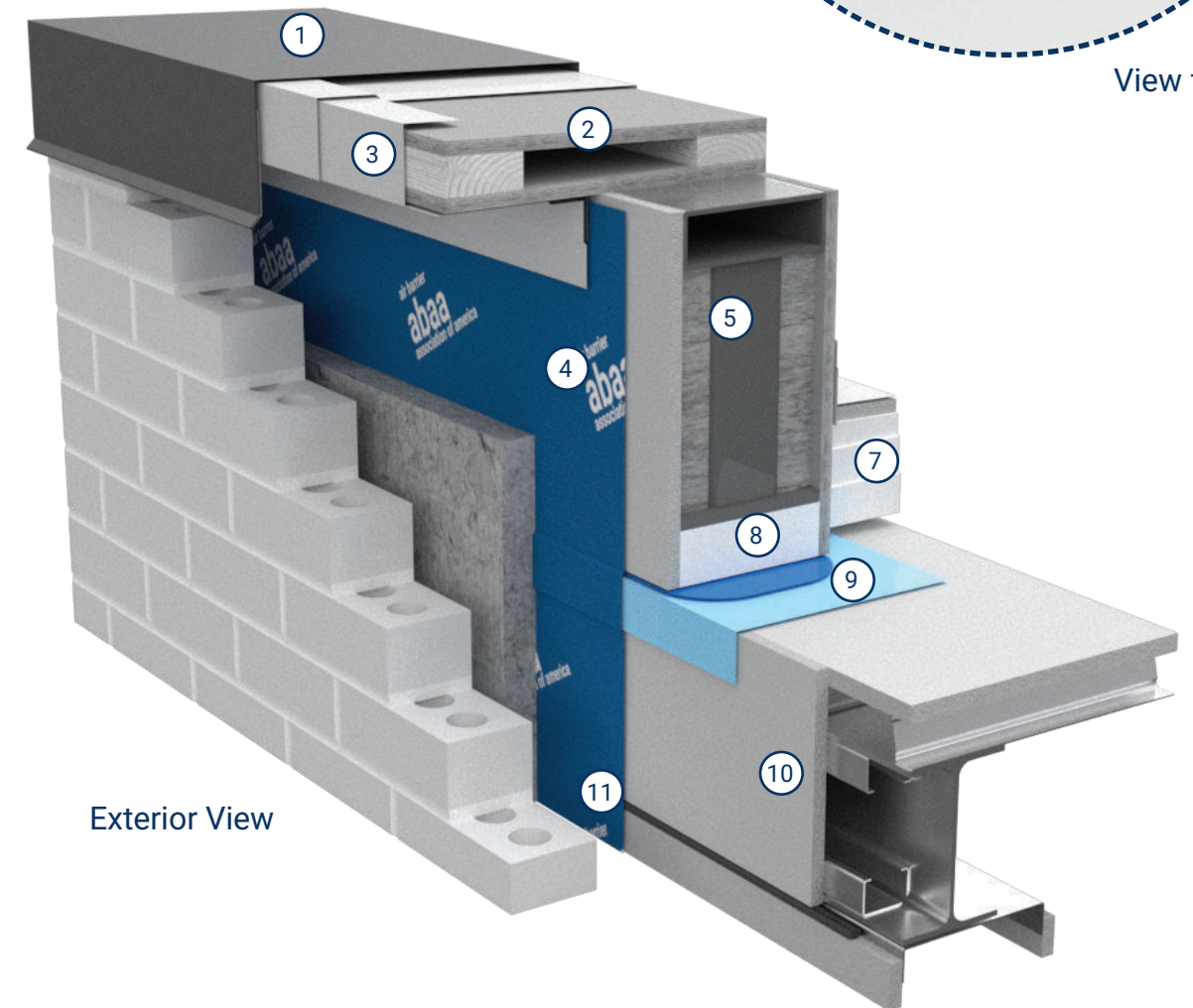

Exterior View

## Rainscreen Wall - Deck Air Barrier Prior to Parapet Extension With Thermal Break (3D)