

# Detail IRS8

## Insulated Sheathing Rainscreen Wall - Air Barrier Installation Prior to Parapet Extension - With Thermal Break (2D)

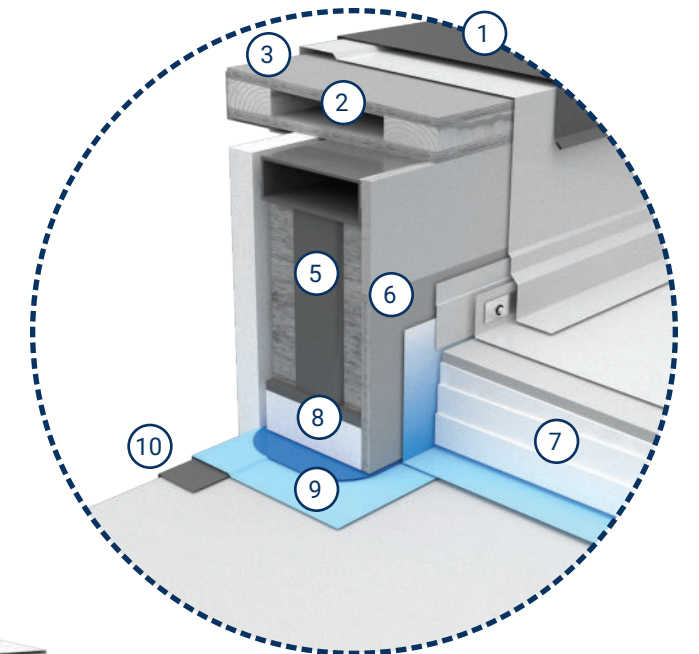

View from Roof

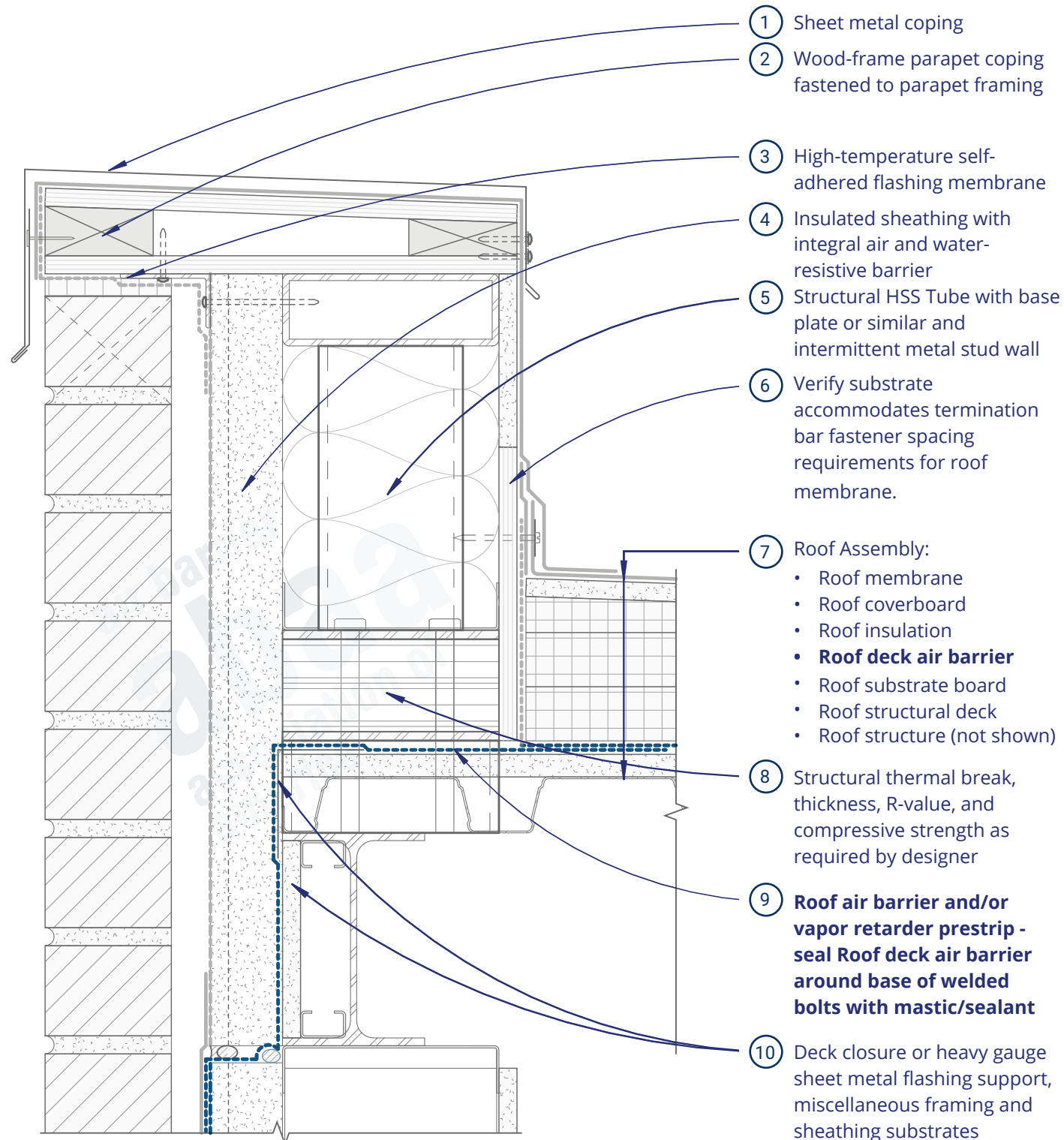
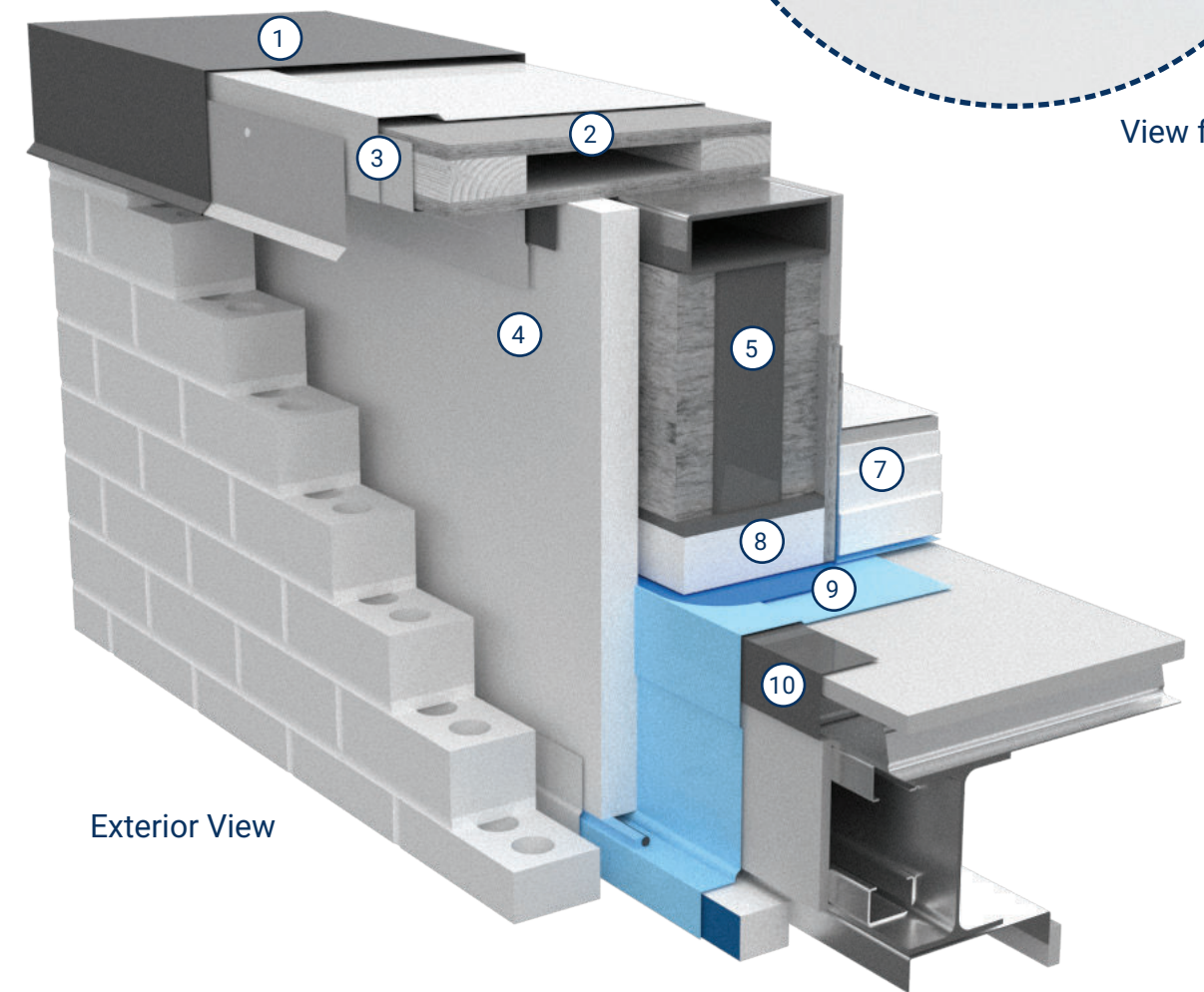

Exterior View

## Insulated Sheathing Rainscreen Wall - Air Barrier Installation Prior to Parapet Extension - With Thermal Break (3D)

**Parapet Details:**  
See General Notes sheet regarding parapet heights, condensation risk, and air and thermal continuity.