

Standard Process for Evaluation of Air, Water-Resistive and Air/Water-Resistive Barrier Materials

Published by the Air Barrier Association of America Inc. (ABAA).

Copyright© 2024 Air Barrier Association of America Inc. (ABAA). All rights reserved.

No part of this publication may be reproduced, stored in a retrieval system or transmitted in any form or by any means, electronic, mechanical, photocopying, recording or otherwise, without the prior written permission of the Air Barrier Association of America, Inc. 1600 Boston-Providence Hwy Walpole, MA 02081 abaa@airbarrier.org.

Contents

Forward.....	v
Introduction	vi
1 Scope	1
2 Normative References	1
3 Terms and Definitions.....	2
4 Material Evaluation Process.....	3
5 Application	4
6 Requirements.....	4
6.1 Material Types.....	4
6.2 Material Sampling	6
6.3 Thickness Tested	5
6.4 Testing.....	5
6.5 Material Used in Assembly Testing	5
7 Testing – Material.....	7
7.1 Material Specification	7
8 Testing – Assemblies.....	6
8.1 Wall Assembly Testing.....	6
8.1.1 Wall Assembly Test Method	6
8.1.2 Base Wall Assemblies.....	6
8.1.3 Wall Specimen Construction	6
8.1.4 Wall Assembly Testing Requirements.....	7
Table 1: Load Requirements for ASTM E2537 Testing	7
8.1.5 Wall Assembly Testing Sequence	8
8.2 Roof Assembly Testing	8
8.2.1 Roof Assembly Test Methods.....	8
8.2.2 Base Roof Assemblies.....	8
8.2.3 Roof Specimen Construction	8
8.2.4 Roof Assembly Testing Requirements.....	9
8.2.5 Roof Assembly Testing Sequence.....	9
Reporting.....	9
9.1 Materials	9
9.2 Assemblies.....	13
10 Review of Documentation	13
11 Renewal	13
12 Suppliers Obligations.....	14
13 Keywords	14
Annex A (normative) Documentation Required	15
Annex B (normative) Flow Chart.....	19
Annex C (normative) Air Barrier Wall Assembly Specimens.....	20

Forward

The procedures used to develop this document and those intended for its further maintenance are described P-114-017 rev 4 ABAA Policy for Balloting Official ABAA Documents.

Please submit any questions or any feedback on this document to abaa@airbarrier.org.

Introduction

For air and water-resistive barrier materials to perform as intended when installed on a building, the air and water-resistive barrier material needs to have certain characteristics and provide a level of performance for the materials as established in the ABAA Material Specification for the type of air barrier, water-resistive barrier, or air and water-resistive barrier material. In addition, integration of air barrier materials with other air barrier components and service penetrations, with the use of air barrier accessories, is critical for the in-service performance of air barrier assemblies and air barrier systems. This document also outlines the process for evaluating air leakage characteristics in air barrier assemblies for both wall and roofing applications.

The ABAA Technical Committee has approved the criteria included in this document through the ABAA document approval process.

1 Scope

This document provides a consistent, documented process for the Air Barrier Association of America (ABAA) evaluation of air barrier materials, water-resistive barrier materials, and air and water-resistive barrier materials, accessories and assemblies. This document defines the requirements and outlines the process for a supplier to have a material, accessory or assembly evaluated by ABAA.

Suppliers who conform to all the requirements of this document can request the material to be listed on the ABAA website under “Evaluated Air Barrier Assemblies” and included in the appropriate ABAA Master Project Specification.

The values stated in SI units are to be regarded as standard. The values given in parentheses are mathematical conversions to inch/pound units that are provided for information only and are not considered standard.

The testing and evaluation of a material against this document may require the use of materials and/or equipment that could be hazardous. This document does not purport to address all the safety aspects associated with its use. Users of this document has the responsibility to consult the appropriate authorities and to establish appropriate health and safety practices in conjunction with any existing applicable regulatory requirements prior to its use.

2 Normative References

The following documents are referred to in the text in such a way that some or all the content constitutes the requirements of this document. For dated references, only the edition cited applies. For undated references, the latest edition of the referenced document (including any amendments) applies.

Documents published by the Air Barrier Association of America, Inc. (ABAA)

1600 Boston Providence Hwy, Walpole, MA 02081 USA

Telephone: (866) 956-5888 Fax: (866) 956-5819

www.airbarrier.org

ABAA P-114-017 rev 4 *ABAA Policy for Balloting Official ABAA Documents*

Document Published by American Society for Testing and Materials (ASTM)

100 Barr Harbor Drive, Conshohocken, PA 19428-2951

P.O. BOX C700, Conshohocken, A 19428-0700

Telephone: (610) 832-9585 Fax: (610) 832-9555

www.astm.org

ASTM C390, *Standard Practice for Sampling and Acceptance of Thermal Insulation Lots*

ASTM D8052, *Standard Test Method for Quantification of Air Leakage in Low-Sloped Membrane Roof Assemblies*

ASTM E96/E96M-21, *Standard Test Methods for Gravimetric Determination of Water Vapor Transmission Rate of Materials*

ASTM E631, *Standard Terminology of Building Constructions*

ASTM E1680, *Standard Test Method for Rate of Air Leakage through Exterior Metal Roof Panel Systems*

ASTM E2178-21a, *Standard Test Method for Determining Air Leakage Rate and Calculation of Air Permeance of Building Materials*

ASTM E2357, *Standard Test Method for Determining Air Leakage of Air Barrier Assemblies*

3 Terms and Definitions

The terms and definitions given in ASTM E631—and the following—apply to this document.

3.1

accredited testing laboratory

organization accredited to ISO 17025 by a member of the IAF/ILAC Multilateral Agreement, possessing the necessary competence to test material to the specific test method.

3.2

air barrier accessory

materials designated to maintain airtightness between air barrier materials, air barrier assemblies, and air barrier components, to fasten them to the structure of the building, or both (e.g., sealants,

tapes, backer rods, transition membranes, nails/washers, ties, clips, staples, strapping, primers).

3.3

air barrier assembly

combination of air barrier materials and air barrier components, sealed together to reduce air leakage with the use of air barrier accessories.

3.4

air barrier component

pre-manufactured elements such as windows, doors and service elements that are installed in the building envelope which met a requirement for a maximum air leakage rate and water ingress.

3.5

air barrier material

primary substance that constitutes the air control layer in the building envelope.

3.6

air barrier supplier

entity that provides a material or product which is declared to be an air barrier material, accessory, component, or an assembly.

3.7

air barrier system

combination of interconnected materials and assemblies designed and constructed to provide a continuous barrier to air leakage through the building envelope that separates conditioned from unconditioned space or that separates adjoining conditioned space of different occupancies or uses (six sides of a building).

3.8

air leakage rate

airflow per unit time driven through a unit surface area at a defined static pressure differential across the material or assembly.

3.9

air permeance

airflow per unit time driven through a unit area at a unit static pressure difference across the material divided by the pressure difference between the two sides.

3.10

building envelope (enclosure)

combination of roof, wall and foundation assemblies comprised of materials, sub-assemblies, and components that when combined using accessories form the primary control layers to separate one environment from another environment.

3.11

membrane

material forming a selective barrier that may or may not allow passage of elements.

3.12

product change

change in the composition of a material, which results in a difference in the material properties of greater than 5 percent.

3.13

sub-assembly

subset of material(s) and accessories(s) that can be tested separately but are part of a complete building assembly.

3.14

water-resistive barrier

material behind an exterior wall covering that is intended to resist liquid water that has penetrated behind the exterior covering from further intruding into the exterior wall.

4 Material Evaluation Process

The ABAA material evaluation process provides a standardized way of evaluating air barrier materials, water-resistive barrier materials, and air and water-resistive barrier materials. The ABAA Technical Committee develops a material specification for each category and type of material, providing the required material properties and performance requirements for each property within the specification.

The material specifications and performance requirement table therein specify the required values for the different material properties. These values are intended for use in specifications, material evaluations, and quality control. The property values are not intended to predict *in situ* end-use material performance, and the values will differ from those reported when tested under different conditions. The installation procedures required by the supplier may affect the materials in situ end-use performance.

ABAA provides the evaluation service for the industry and publishes information on whether the material performance has met the requirements outlined by ABAA. The user shall determine whether a material is suitable for in situ applications on a building.

ABAA has developed material requirements for an air barrier or water-resistive barrier application. In addition to resisting water or reducing airflow through the material, further material property requirements for each type of material need to be met for the material to be considered for listing by ABAA.

5 Application

The supplier shall complete a membership application form, material evaluation form, mutual nondisclosure agreement, and licencing agreement available at <https://www.airbarrier.org/air-barrier-material-evaluation/> and provide the documentation listed in Annex A.

If the supplier feels that the material does not fit into an existing material specification, the supplier may request that ABAA develop a new material specification for the proposed type of material. ABAA would consider developing a new material specification for the type of material proposed, if that material is deemed not to fit into existing material types.

ABAA will list the material on the ABAA website only when the supplier meets all material testing, assembly testing, reporting, and documentation requirements.

6 Requirements

6.1 Material Types

ABAA has developed a listing system separates materials into categories (air, water-resistive, and air and water-resistive barriers) and then types. Each material specification includes requirements that are specific to that material type. Suppliers looking to have a material evaluated by ABAA shall review the documents to see where a material may fit. The supplier can then download the material specification for that material type to determine the material property requirements. When the supplier's material type is not readily apparent, the supplier shall contact ABAA for assistance in determining the proper material type.

6.2 Material Sampling

The accredited testing laboratory determining compliance to this document is responsible for the random sampling of the material. Sampling shall be performed in accordance with the principles of ASTM C390. Randomly select enough material on a single occasion from a single lot to complete all testing to determine compliance with this document.

The supplier shall ensure that sufficient material—both in size and quantity—is available for sampling and testing.

Where additional material is required, obtain it from the same lot as the originally selected material or a lot that has the same material properties, formulation, and manufacturing process.

6.3 Thickness Tested

The thickness of the material tested shall be the same for all tests conducted following the ABAA Material Specification. Test reports' rejection will occur when different thicknesses are used for various test methods unless specifically required in the test method. If a supplier declares another thickness requirement for that material in the future, ABAA shall consider that to be new material and require documentation for the air leakage rate of the material (ASTM E2178), air leakage of the assembly [(ASTM E2357), (ASTM E1680) or (ASTM D8052)] and water vapor transmission (ASTM E96).

6.4 Testing

The testing is required to be performed by an accredited testing laboratory.

Testing shall follow the latest edition or cited edition, if indicated, of the test method. For dated references, only the edition cited applies. For undated references, the latest edition of the referenced document (including any amendments) applies.

6.5 Material Used in Assembly Testing

When conducting assembly testing, the material installed into the wall air barrier assemblies, roof air barrier assemblies, and water-resistive barrier assemblies shall be the same evaluated material. The thickness of the material in the assembly shall be the supplier's declared installed thickness and material tested thickness. All accessories used to construct the building assembly are to be the

supplier's required accessories for the material being tested. These accessories are to be included in the test report.

7 Testing – Material

7.1 Material Specification

The material shall meet the requirements listed in ABAA Material Specification for the specific material type.

8 Testing – Assemblies

The requirements listed in this document for testing of assemblies include the tested material along with the general evaluation and documentation required by the ABAA evaluation process.

The tested material thickness shall be consistent for all material testing (material, sub-assembly, and assembly). The required installed thickness shall be equal to the thickness tested to show conformance to the material property requirements of the relevant ABAA Material Specification.

The material installed into the assembly shall be the same as used for all test reports submitted for evaluation, with no product changes. In the case of fluid-applied materials, the installed dry thickness shall equal the required dry mil thickness of the tested material.

8.1 Wall Assembly Testing

Any material that ABAA evaluates and lists on the ABAA website shall meet both the material and assembly requirements.

8.1.1 Wall Assembly Test Method

All materials shall be tested as part of a wall air barrier assembly following ASTM E2357 *Standard Test Method for Determining Air Leakage of Air Barrier Assemblies* by an accredited testing laboratory. (See **Table 1** for optional Structural Wind Loading Schedule for wind pressure conditioning.) Type 1 is the ASTM E2357 default wind pressure conditioning. The supplier may request the laboratory test at a higher type of level and have the higher type clearly identified on the report and recognized by ABAA.

8.1.2 Base Wall Assemblies

The base specimen walls, constructed by either the accredited testing laboratory or the supplier under the supervision of the accredited testing laboratory, shall follow the base wall construction instructions in Annex C. The supplier can choose which type (wood, steel stud or CMU) of backup wall to install the air barrier materials and accessories. Only one type of wall is required to be tested.

8.1.3 Wall Specimen Construction

The air barrier assembly specimen shall be constructed by installing the air barrier material and accessories on the base wall assemblies. A qualified installer shall install the materials and accessories following the supplier's installation instructions. Any additions, deletions, or deviations to the installation instructions shall be documented and provided in the test report. Installation instructions shall include information on:

- A Acceptable substrate and a list of any substrates not approved.
- B Substrate preparation for each type of substrate. Indicate when material will be directly installed onto the framing without a substrate support.
- C Ambient and substrate conditions required for installation (e.g., temperature, wind, humidity, precipitation, falling temperature, etc.).
- D Installation method (e.g., mechanically fastened, trowel on, roll on or spray on).
- E Sequence and technique details for installation, penetrations, terminations, and transitions.
- F Material compatibility listing – both mechanical and chemical.
- G Listing of acceptable primers and sealants.
- H For fluid-applied membranes – required site installed thickness that is the air barrier material tested thickness without any substrate.
- I Installation details for the assembly showing each air barrier accessory.

8.1.4 Wall Assembly Testing Requirements

The testing shall follow the procedures in ASTM E2357. Wall Specimens shall be conditioned for a minimum of 24 hours at laboratory conditions. The supplier shall use either the existing loads included in ASTM E2357 (Type 1) or may test to higher loads. The supplier may choose from the following loads.

**Table 1:
 Optional Structural (Wind) Loading Schedule for ASTM E2537
 Testing**

Type	P_1, P'_1 sustained for one hour (Pa)	P_2, P'_2 2000 cycles (Pa)	P_3, P'_3 gust wind (Pa)
1 (ASTM E2357)	600	800	1200
2	1500	2000	2400
3	2800	3800	4400
4	3100	4100	4800
5	3300	4300	5100
6	3400	4500	5300
7	3600	4700	5500

The calculated air leakage rate through the test specimen per ASTM E2357 shall not be greater than 0.20 L/s·m² at a pressure differential of 75 Pa [0.04 cfm/ft² at a pressure differential of 1.57 psf] when tested in both directions. The result shall be recorded to a minimum of three decimal places. The test report shall indicate the pressures used in the test.

8.1.5 Wall Assembly Testing Sequence

The base wall is to be constructed in accordance with Annex C Air Barrier Wall Assembly Specimens. The air barrier/water-resistive barrier material is to be installed according to the supplier's published installation instructions and to the supplier's published installation thickness. Where required, the material shall be cured. The specimen is to be tested in accordance with ASTM E2357 at the supplier's chosen structural loading pressures choose from Table 1. After completion of the test and without removing the specimen from the test apparatus, the brick ties are to be installed according to the brick-tie supplier's instructions with any additional requirements of the air/water-resistive barrier supplier's requirements. The ASTM E2357 test is to be run for a second time after the brick ties have been installed. Results of both tests are to be included.

8.2 Roof Assembly Testing

All roof air barrier materials to be evaluated by ABAA shall be incorporated into and tested as part of a roof air-barrier assembly in conformance with the latest version of the standard.

8.2.1 Roof Assembly Test Methods

Use one of the following test methods depending on the roof construction type.

- A ASTM D8052 Standard Test Method for Quantification of Air Leakage in Low-Sloped Membrane Roof Assemblies for ABAA evaluation of low-slope roof assemblies, or;
- B ASTM E1680 Standard Test Method for Rate of Air Leakage through Exterior Metal Roof Panel Systems for metal roofs.

8.2.2 Base Roof Assemblies

The base specimen roof assemblies shall be constructed following the test method specimen requirements by either the accredited testing laboratory or the supplier under supervision of the accredited testing laboratory.

8.2.3 Roof Specimen Construction

A qualified installer shall install the materials and accessories following the supplier's installation instructions. Any additions, deletions, or deviations to the installation instructions shall be documented and provided in the test report. Installation instructions shall include information on:

- A Acceptable substrate and a list of any substrates not approved;
- B Substrate preparation for each type of substrate;
- C Ambient and substrate conditions required for installation (e.g., temperature, wind, humidity, precipitation, falling temperature, etc.);
- D Installation requirements including minimum dry mil thickness for fluid-applied materials;

- E Sequence and technique details for installation, penetrations, terminations and transitions;
- F Material compatibility listing – both mechanical and chemical;
- G Listing of acceptable primers and sealants.

8.2.4 Roof Assembly Testing Requirements

Test methods ASTM D8052 or ASTM E1680 provide the loads and conditions under which the air barrier materials and air barrier accessories must be evaluated when combined as a roof assembly.

The calculated air leakage rate through the test specimen per ASTM D8052 or ASTM E1680 shall not be greater than 0.20 L/s-m² at a pressure differential of 75 Pa [0.04 cfm/ft² at a pressure differential of 1.57 psf when tested in both directions. The result shall be recorded to a minimum of three decimal places at a pressure differential of 75 Pa [0.0002 cfm/ft² at a pressure differential of 1.57 psf].

9 Reporting

The supplier requesting evaluation shall compile and submit, to ABAA, all documentation and reports required, as listed in Annex A. Once received, ABAA will review the completed documentation package to ensure all information is received and communicate with the supplier for clarification or missing items.

The date on any report or document shall not be more than five years old when submitted for evaluation.

9.1 Materials

The supplier shall submit a complete set of test reports including the information as required by the ABAA Material Specification for the specific type of material. The test report for each material property shall state that the laboratory followed the test method with no modifications—other than modifications—included in the ABAA Material Specification. If the test report does not contain complete information, the ABAA office will reject the report.

9.2 Assemblies

The supplier shall submit a complete test report including the information as required by ASTM E2357, ASTM D8052 or ASTM E1680. The report shall specify the conditions utilized within ASTM E2357, ASTM D8052 or ASTM E1680 that, and if loads under which the wall assembly were tested differ from ASTM E2357 (include the loads from **Table 1**), ASTM D8052 or ASTM E1680. The test report is to include results of the specimen without the brick-ties installed and then a second set of results after the brick-ties installed.

10 Review of Documentation

The technical completeness and consistency review will consist of the following:

- A Review of test reports
- B Review of specifications, installation instructions and product limitations

Where needed, the ABAA office will forward an itemized checklist with comments to the supplier outlining requests for further information, clarification or documentation.

Upon completion of the technical document review, the ABAA office will advise the supplier of approval or disapproval.

The assembly is listed on the ABAA website only after the final review has confirmed that all information required, including the test report for assembly testing is received, reviewed, and approved. Upon final approval, work shall commence on inserting the material in the appropriate master project specification.

11 Renewal

ABAA can randomly choose material sold in the marketplace and have the material tested to confirm that selected material properties (when tested) are comparable to the test report submitted for evaluation. The specific tests chosen will depend on the material category/type.

The results of any material property, if tested, shall be within 5 percent of the initial values submitted at the time of evaluation. The ABAA office shall remove the listing if the material has changed

more than 5 percent, or the supplier has not confirmed the listed material properties have not changed.

The license renewal occurs on an annual basis on December 31.

Every five years, the supplier shall declare/confirm that the air barrier materials, components or assemblies have not changed from the original submission or shall submit new test results for their material.

The ABAA office shall remove the listing if the supplier has not confirmed the material properties, components, materials and assemblies have not changed or supplied a new set of test reports.

12 Supplier's Obligations

The supplier shall consult with ABAA to determine the appropriate air, water-resistive or air and water-resistive barrier type for a material. If the material type does not fit into the existing ABAA Material Specifications, ABAA may decide to develop a new material specification for the type of material proposed.

When a supplier has provided the documentation required to have a material, accessory or assembly listed with ABAA, the supplier must sign a Licensing Agreement that would formalize the requirements to maintain a listing by ABAA. The licensed supplier may promote themselves as a "licensed supplier" and having an ABAA Evaluated material.

The Licensing Agreement includes ongoing maintenance requirements such as:

- A Maintaining professionalism;
- B Prompt submission of test results and documentation when product changes occur;
- C Internal audit every five years that would review supplier's documentation, and;
- D Compliance with the License Agreement.

13 Keywords

air barrier, water-resistive, membrane

**Annex A
(normative)**

**Documentation
Required
for Evaluating Assemblies to be Listed on the ABAA
Website**

The supplier shall submit the following documentation (signed) to the ABAA office for review.

Application Form

The supplier shall complete the application form for each material to be evaluated by ABAA.

ABAA Licensing Agreement

ABAA Licensing Agreement shall be completed and signed by the supplier (only once).

Non-Disclosure Agreement

ABAA Non-Disclosure Agreement shall be completed and signed by the supplier (only once).

Test Reports

The supplier shall provide a complete copy of each test report required by the ABAA material specification or material requirement table for the specific category and type of material along with the test report for the air barrier assembly.

Supporting Documentation

The supplier shall submit the following documentation for each air barrier material:

- A Technical data sheet for the material
- B Supplier guide/master specification for the material

- C SDS for materials as delivered to project site and for the finished material if manufactured on site.
- D For wall air barrier materials, typical wall construction details (indicate if climate-specific) that include the following as a minimum.
 - 1. roof/wall
 - 2. wall/foundation
 - 3. window/wall
 - 4. expansion joint
 - 5. change in plane
 - 6. change in substrate
 - 7. penetrations
 - 8. inter-story connections
 - 9. deflection joints
 - 10. substrate joints
 - 11. Installation instructions that include information on:
 - a. substrate preparation
 - b. required ambient and substrate conditions (e.g., temperature, moisture content, wind, humidity, precipitation, falling temperature, etc.)
 - c. application method (e.g., mechanically fastened, trowel on, roll on, or spray on)
 - d. sequence and technique for installation of air barrier materials and air barrier accessories
 - e. material compatibility listing
 - f. air barrier accessories
 - g. for fluid-applied membranes: minimum installation thickness based on the thickness of the air barrier material only, used for the testing without any substrate. Indicate when the air barrier material is installed directly on the framing without any substrate
 - h. list of substrates that the material can be installed on and specifically list any substrate where the supplier does not recommend installation
 - i. Service temperature of installed material
 - j. Declared VOC content in g/l and test method or declared emission compliance or certification
 - k. Maximum allowed UV exposure
 - l. Shelf life of material
 - m. Storage requirements

- E For roof air barrier materials, typical roof construction details (indicate if climate-specific) that include the following as a minimum.
1. roof/wall
 2. expansion joint
 3. change in the plane
 4. change in substrate
 5. penetrations
 6. deflection joints
 7. substrate joints
 8. Installation instructions that include information on.
 - a. substrate preparation
 - b. required ambient and substrate conditions (e.g., temperature, moisture content, wind, humidity, precipitation, falling temperature, etc.)
 - c. application method (e.g., mechanically fastened, trowel on, roll on, or spray on)
 - d. sequence and technique for installation of air barrier materials and air barrier accessories
 - e. material compatibility listing
 - f. listing of air barrier accessories
 - g. for fluid-applied membranes - minimum installation thickness based on the thickness of the material used for testing
 - h. list of substrates that the material can be installed on and specifically list any substrate where the supplier does not recommend installation
 - i. Service temperature of installed material
 - j. Declared VOC content in g/l and test method or declared emission compliance or certification
 - k. Maximum allowed UV exposure
 - l. Shelf life of material
- F Supplier's logo [Provide logo electronically in vector format (.eps or .ai)]
- G Submission of representative product samples
1. The supplier shall submit three material samples,
 - a. Each sample shall be a minimum size of 120 square inches.

Annex B
 (normative)

Flow Chart

ABAA Process for Evaluation of Air Barrier Materials,
 Accessories, Components, and Assemblies

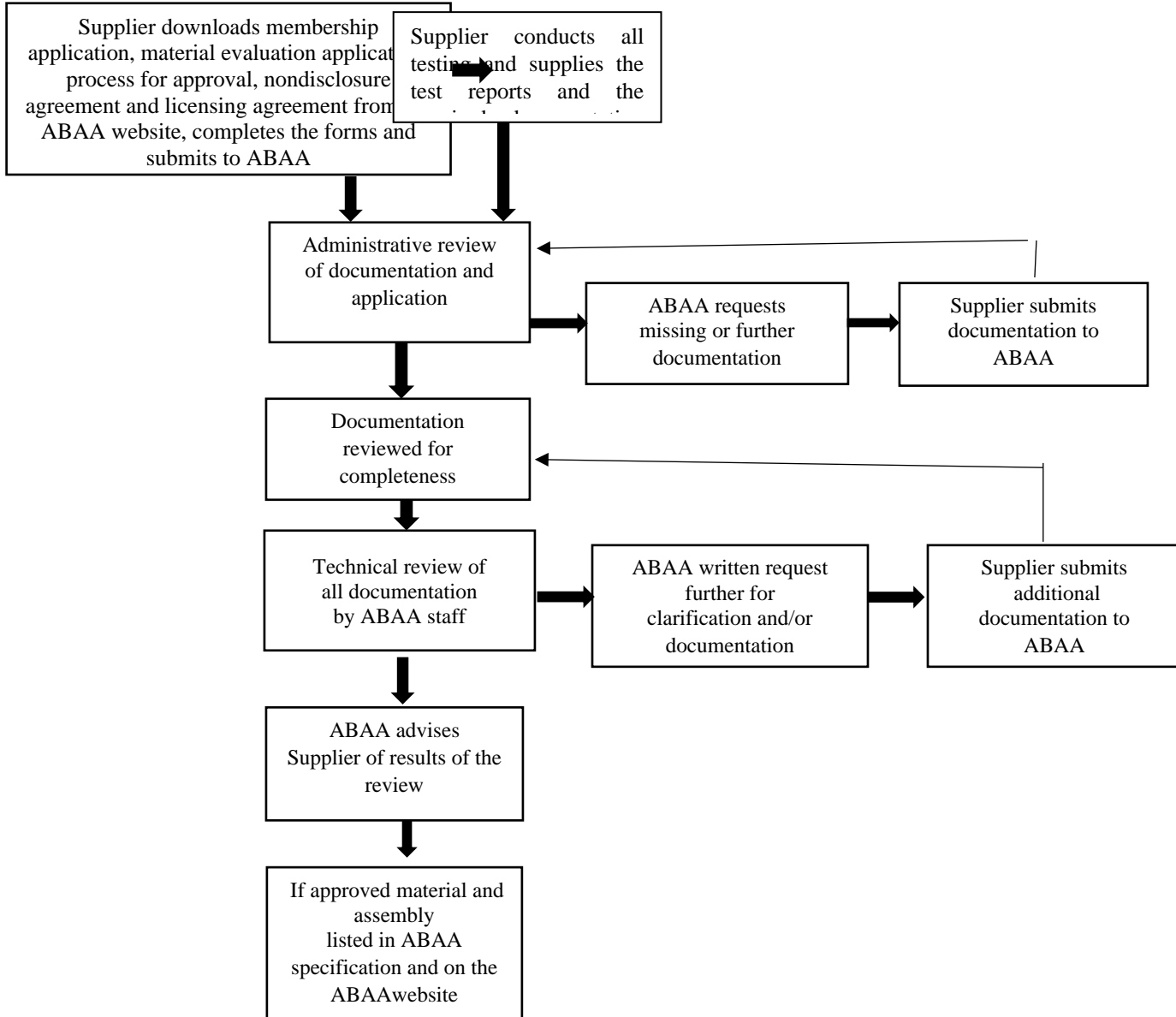

Annex C (normative)

Air Barrier Wall Assembly Specimens

The base wall requires standardization for testing, so the only variation between tests conducted by different suppliers is the air barrier materials and accessories used to create an air barrier wall assembly. The base wall has gaps incorporated into the specimen to mirror typical construction on a project site.

The key on the following page lists the numbered components for all specimen drawings, where referenced in the text the material numbers will be show in brackets.

Key to Specimen Drawings

1. 37 mm x 235 mm (2-inch x 10-inch) wood buck on all four sides with the corners sealed airtight
2. CMU medium density 400 mm x 200 mm x 150 mm (16-inch x 8-inch x 6-inch)
3. Wood mud sill 37 mm x 140 mm (2-inch by 6-inch)
4. Rim joist 37 mm x 140 mm (2-inch by 6-inch)
5. Floor joist 37 mm x 140 mm (2-inch by 6-inch)
6. Plywood sub-floor 16 mm (5/8-inch)
7. Wood plate 37 mm x 89 mm (2-inch x 4-inch)
8. Wood stud 37 mm x 100 mm (2-inch by 4-inch)
9. OSB sheathing 11 mm (7/16-inch) or the structural air barrier material itself
10. Sheet metal angle 26-gauge 100 mm x 100 mm (4-inch x 4-inch) – corners and joints sealed
11. Air and water-resistive barrier material – if in rolls, sheets, or boards, install with at least two horizontal joints and three vertical joints
12. Brick ties – corrugated surface mount or equivalent
13. Window blank – constructed with a 37 mm x 89 mm (2-inch x 4-inch) wood frame rabbited for a panel of 16 mm (5/8-inch) plywood installed into the wood frame. All joints sealed and covered with three coats of urethane
14. Electrical box – octagon surface mount
15. Electrical box – octagon recessed mount
16. Electrical box – square double gang surface mount
17. Electrical box – square double gang recessed mount
18. Pipe – PVC 38 mm (1½-inch) diameter
19. Duct – square galvanized 100 mm x 100 mm (4-inch x 4-inch)
20. Floor – poured concrete 100 mm (4-inch) thick
21. Steel track – galvanized 100 mm (4-inch)
22. Steel stud – galvanized 100 mm (4-inch)
23. Exterior sheathing – fiberglass mat faced gypsum-based 16 mm (5/8-inch) installed with 3 mm (1/8-inch) gaps on all joints or the structural air barrier material itself
24. Brick ties – corrugated sheet metal anchors minimum size of 22 gage x 7/8-inch-wide with corrugation wavelength between 0.3 to 0.5 inch, and an amplitude of 0.06 to 0.1 inch. They are to be installed with screws. The fastener must be located within ½ inch of the 90-degree bend in the anchor.
25. Steel channel – 250 mm (10-inch)
26. Brick tie – eye wire

Wood Stud Construction Wall Specimen without Penetrations and Terminations

Wood Buck

Construct a wood buck by assembling a 37 mm x 235 mm (2-inch x 10-inch) [1] wood frame to fit the specimen. The corners are to be sealed and fastened with wood screws to provide an airtight structure when placed up against the airflow apparatus. A 16-gauge sheet metal angle [10] covers the wood buck's front edge and extends 100 mm (4-inch) back on the inside of the wood buck on all four sides.

Foundation/Floor Assembly

The foundation/floor assembly includes:

- A One row of 150 mm (6-inch) deep CMU [2] placed on the wood buck with joints between the CMUs filled with mortar.
- B Wood mudsill (37 mm x 140 mm (2-inch x 6-inch) [3] with a 3 mm (1/8-inch) gauged gap between the mudsill and the CMU
- C Mock floor: comprised of a 37 mm x 140 mm (2-inch x 6-inch) rim joist [4] and 140 mm (6-inch) long, 37 mm x 140 mm (2-inch x 6-inch) joists [5] spaced every 400 mm (16-inch).
- D Subfloor 16 mm (5/8-inch) thick plywood sub-floor [6] was installed over the wood floor joists with 3 mm (1/8-inch) thick shims between the sub-floor and the wood joists halfway between the floor joists.

Wall Assembly

The wall assembly includes:

- A Wood-framed wall consisting of a 37 mm x 89 mm (2-inch x 4-inch) wood bottom plate (7), 37 mm x 89 mm (2-inch x 4-inch) wood studs [8] spaced 600 mm (24-inch) on center, and two 37 mm x 89 mm (2-inch x 4-inch) wood top plates [7] fasten with nails or screws.
- B Sheathing 11 mm (7/16-inch) thick OSB [9]

1. Secured in place with screws or nails in accordance with code requirements for the load selected for testing.
2. Horizontal joint at mid-height (halfway) in the wall
3. Vertical joint in each row of sheathing, offset two stud cavities from each other.
4. All vertical joints shall be on a wood stud.
5. Terminating at the bottom of the mudsill
6. 3 mm (1/8-inch) nominal gap at every joint between sheathing

- C Wall specimen installed in the wood buck with a 3 mm (1/8-inch) nominal gap between the framing members and the wood buck.

C.1.1 Air and/or Water-resistive Barrier Installation

A qualified installer shall install the air barrier materials and accessories [11] following the supplier's installation instructions, including joints for sheet or board material. Any additions, deletions, or deviations to the installation instructions shall be documented and provided in the test report. The installation shall detail the connection between the wood wall and the CMU foundation and the wall and the wood buck, including the metal cladding on the wood buck.

C.1.2 Brick Tie Installation

the brick ties are to be installed after the air/water-resistive barrier material has been installed and allowed to cure, install surface mount brick ties thirty [30] equally spaced into the wood studs. Surface mount brick ties shall be installed following the brick tie supplier's instructions and detailed following the air barrier supplier's instructions.

Specimen C.1 Wood Stud Construction

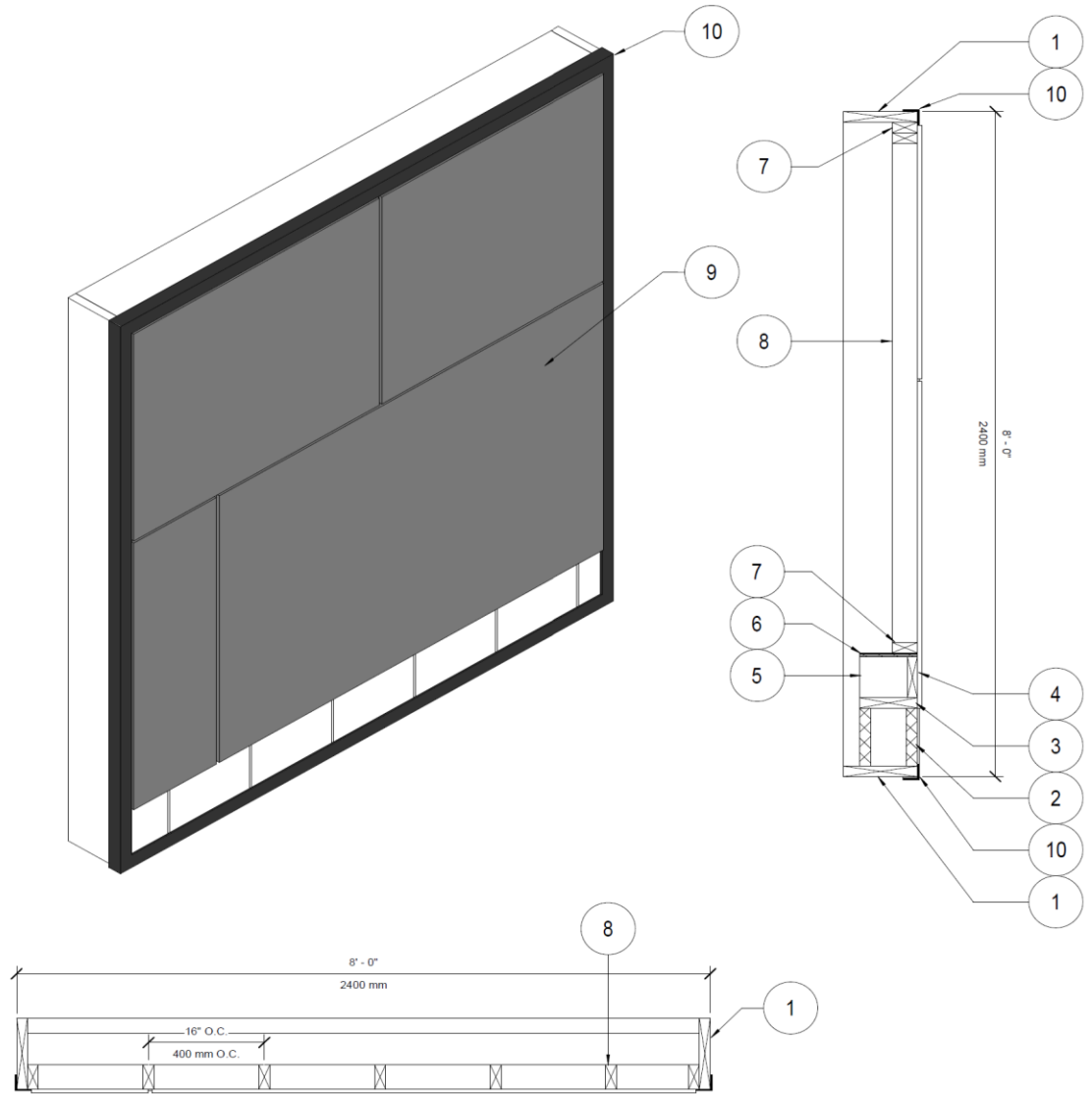

Figure 1
Base Wall: Wood Stud Specimen – Exterior View

Specimen C.1 Wood Stud Construction

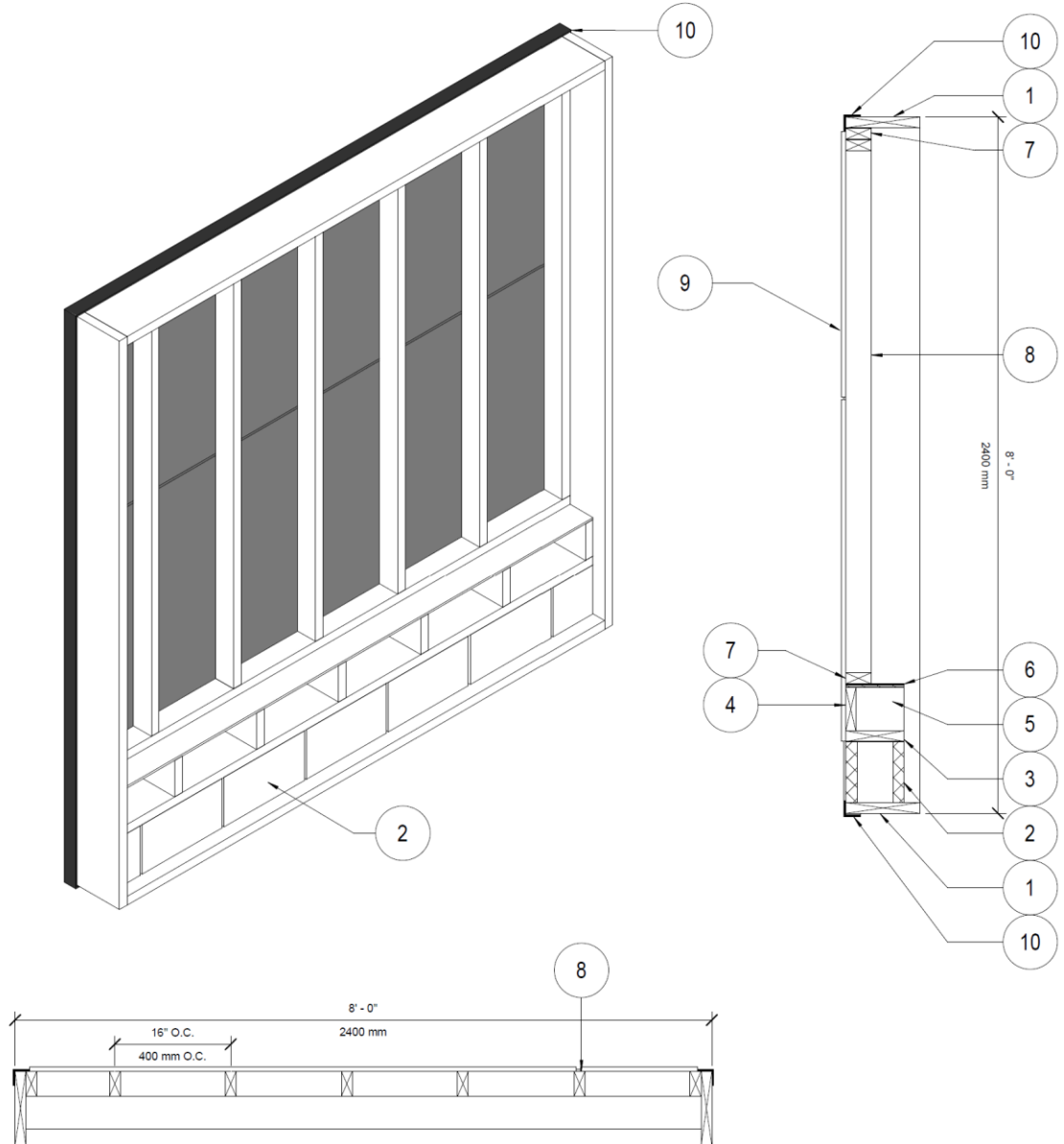

Figure 2
Base Wall: Wood Stud Specimen – Interior View

Specimen C.1 Wood Stud Construction

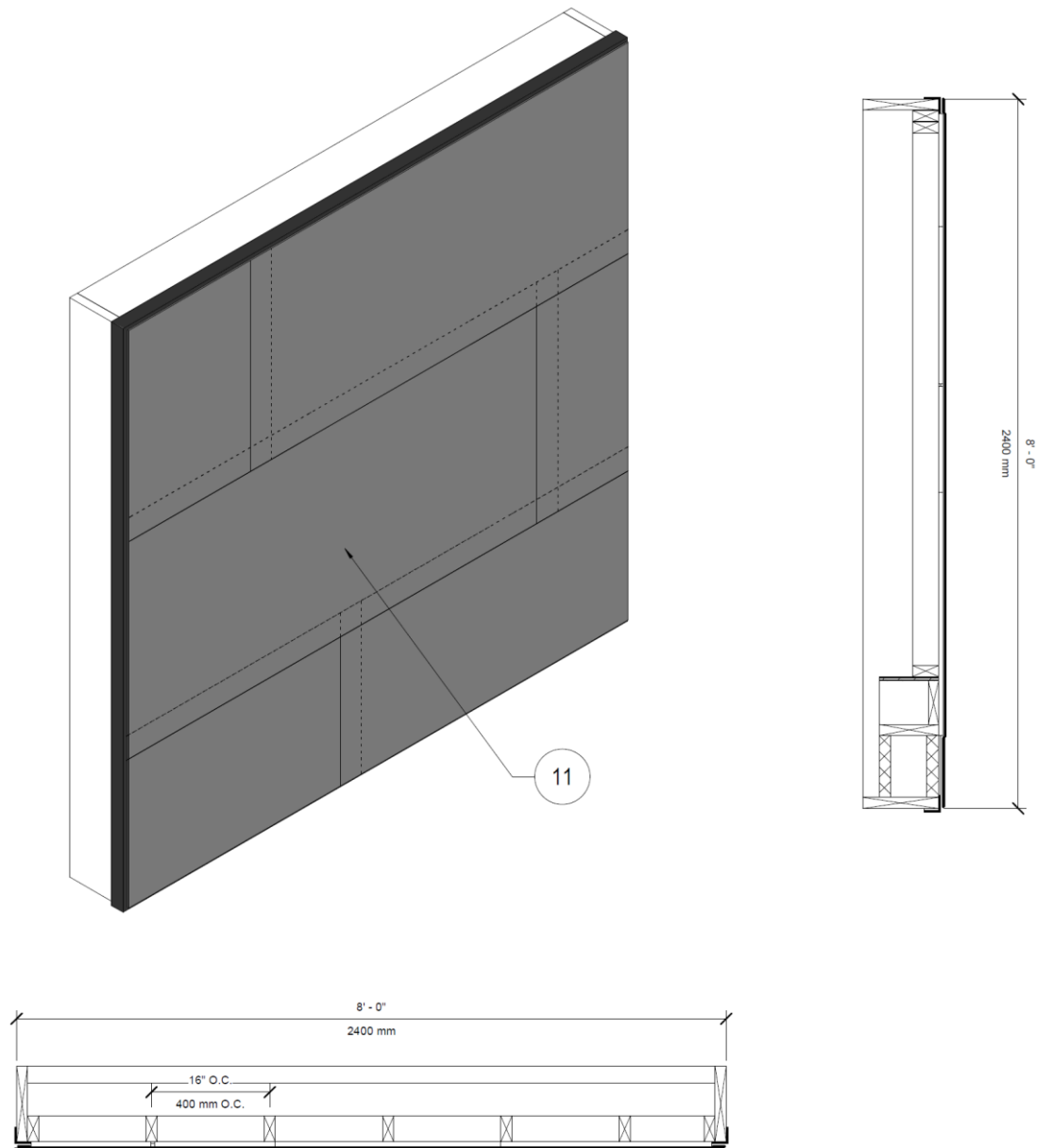

Figure 3
**Base wall: Wood Stud Specimen – Air and/or Water-
resistive Barrier Installed**

Specimen C.1 Wood Stud Construction

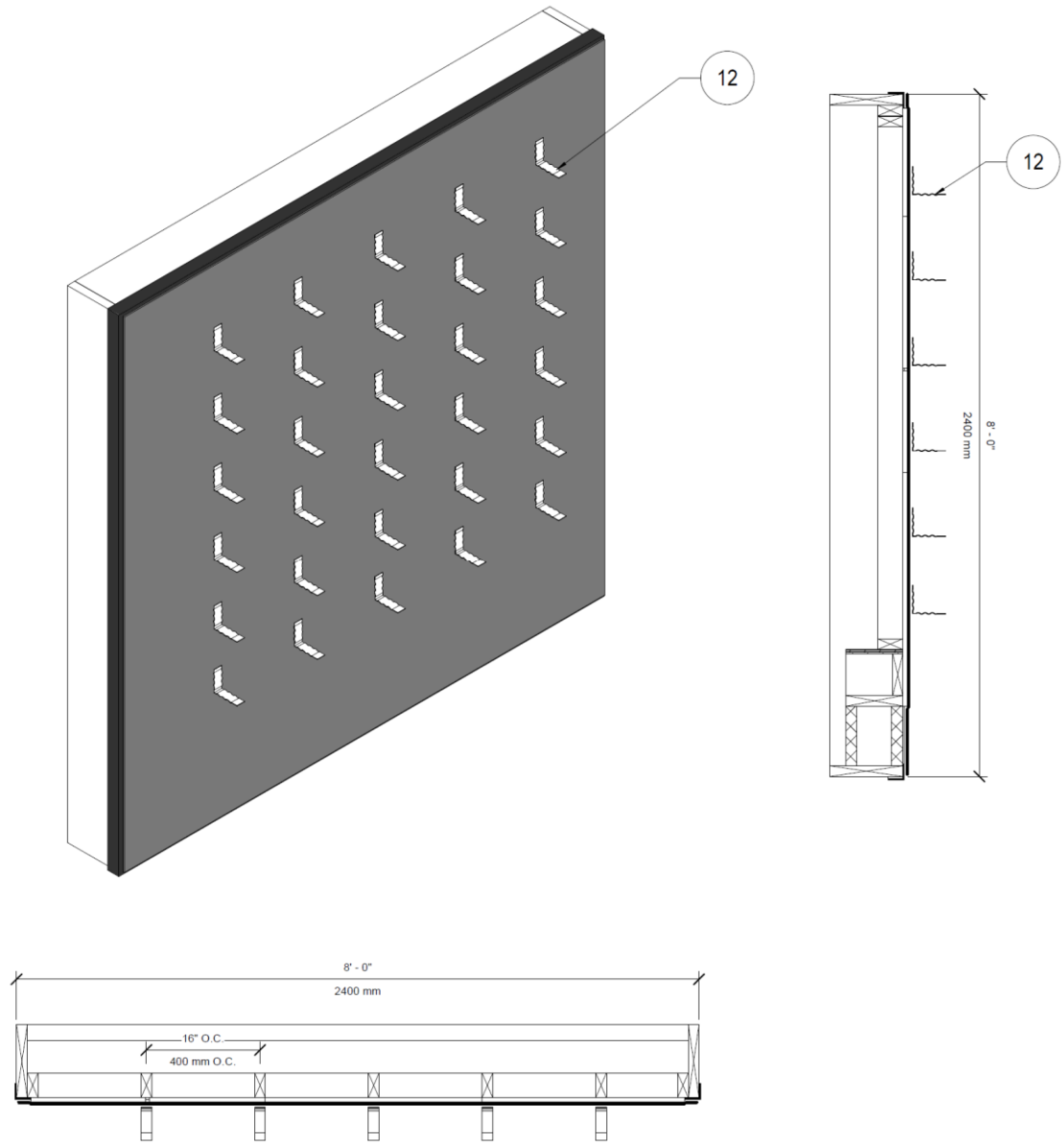

Figure 4
Base Wall: Wood Stud Specimen – Brick Ties Installed

C.2 Wood Stud Construction Wall Specimen with Penetrations and Terminations

Construct a second specimen following the exact requirements as specified in Annex Section C.1 except brick ties are not required and the wall specimen shall include the following:

- A A window rough opening constructed in the wall measuring 800 mm by 800 mm including:
 - 1. A single 50 mm x 100 mm (2-inch x 4-inch) wood plate installed at the top and bottom of the rough opening between two stud openings.
 - 2. A blank window constructed with outside dimensions of 750 mm by 750 mm (30-inch x 30-inch) nominal, leaving a 12 mm (1/2-inch) space between the rough opening and the blank window.
 - a. The blank window includes a bare, medium density plywood window blank sealed and secured into a rabbeted wood buck.
- B Surface-mounted [14,16] and recessed [15,17] junction boxes.
 - 1. The boxes may be proprietary and form part of the continuity of the proprietary air barrier assembly or conventional boxes that are air sealed with air barrier materials and/or accessories.
 - 2. The published test report shall state the methodology used to seal junction boxes.
- C A PVC pipe [18] with a 38 mm (1½-inch) nominal outside diameter
 - 1. The hole made in the substrate to install the pipe shall be 60 mm (2 ¼-inch) diameter to allowing an approximately 12 mm (1/2 inch) gap between the pipe and the rough opening hole in the sheathing around the pipe.
- D A galvanized steel duct [19] measuring 100 mm by 100 mm (4-inch x 4-inch)

1. The hole made in the substrate to install the duct shall be 125 mm by 125 mm (5-inch x 5-inch) nominal to allowing an approximately 12 mm (1/2 inch) gap between the duct and the rough opening hole in the sheathing around the duct.

Specimen C.2 Wood Stud Construction with Penetrations and Terminations

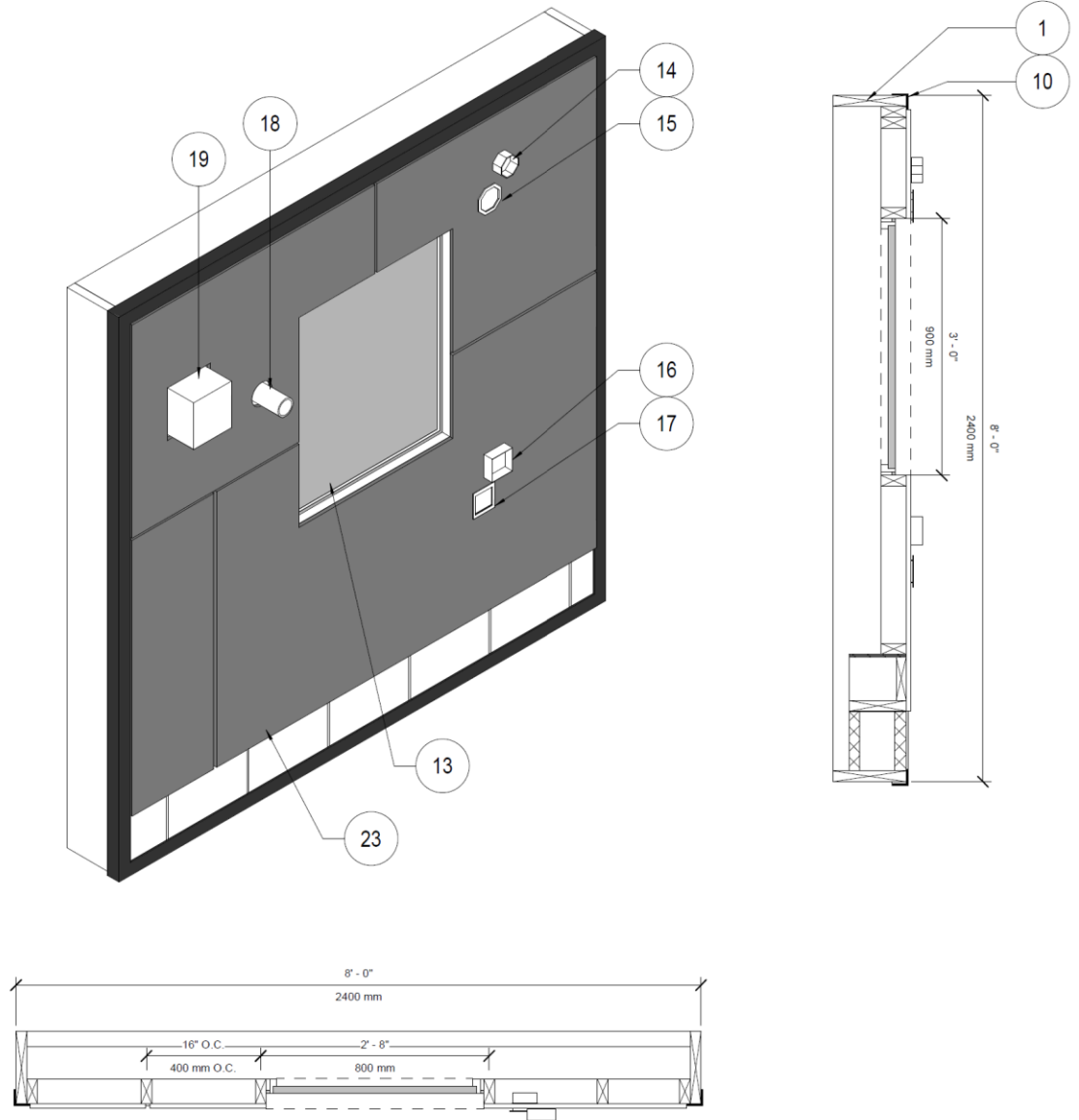

Figure 5
Base Wall: Wood Stud Specimen – Exterior View with Penetrations

**Specimen C.2 Wood Stud Construction with Penetrations
and Terminations**

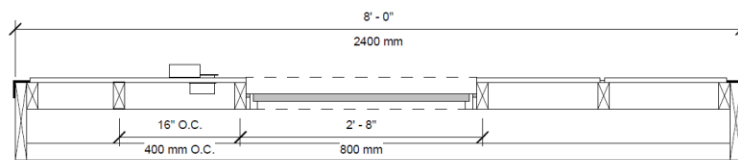
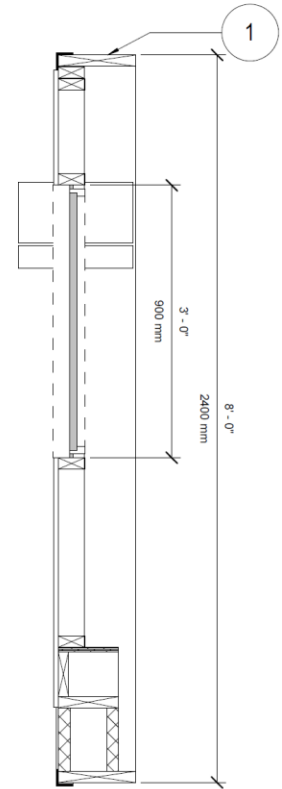
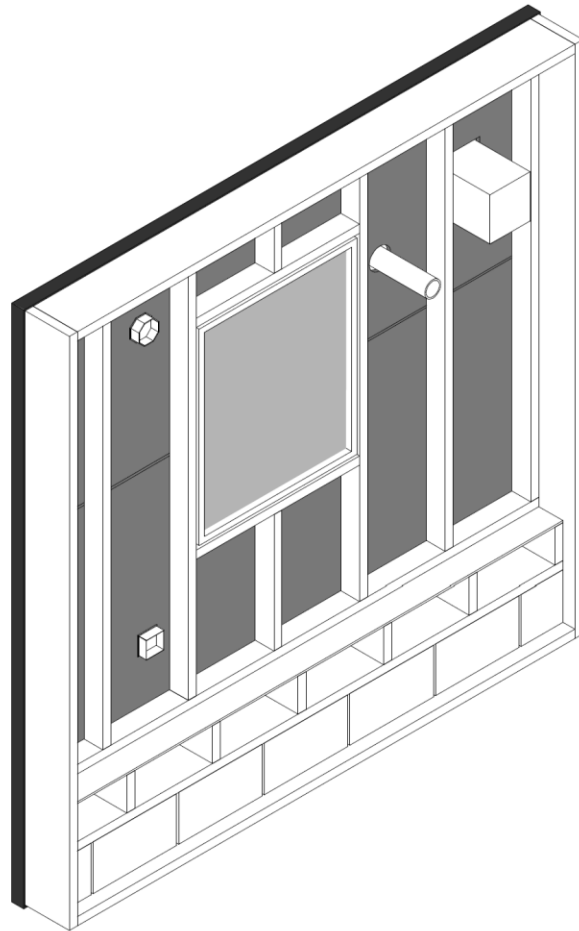

Figure 6
Base Wall: Wood Stud Specimen – Interior View with Penetrations

C.3 Steel Stud Construction Wall Specimen without Penetrations and Terminations

C.3.1 Wood Buck

A wood buck [1] is constructed by assembling a 50 mm x 250 mm (2-inch x 10-inch) wood frame into which the specimen wall will be built. The corners are to be sealed and fastened with wood screws to provide an airtight frame when placed up against the airflow apparatus. A 26-gauge sheet angle [10] shall be installed which covers the edge of the wood buck and extends 100 mm (4 -inch) back on the wood buck on the top and both sides of the wood buck.

C.3.2 Foundation/Floor Assembly

The base wall has a 200 mm x 200 mm (8-inch x 8-inch) poured concrete floor [20] installed in the wood buck.

C.3.3 Wall Assembly

Construct a steel stud framed wall consisting of a 90 mm (3½-inch) wide steel track, top and bottom [21], 90 mm (3½-inch) steel studs [22] spaced 400 mm (16-inch) on center. The framing members shall be secured with fasteners. The framing is then sheathed with a 16 mm (5/8-inch) thick fiberglass mat faced gypsum-based board [23] and fastened in place with drywall screws. The sheathing shall have a horizontal joint at mid-height in the wall, and there shall be a vertical joint in each row of sheathing, offset from each other, and vertical joints shall be on a stud. There shall be a 3 mm (1/8 inch) nominal gap at every joint in the gypsum sheathing, including between the gypsum sheathing and the wood buck. The wall is to be installed in the wood buck with a 3 mm (1/8-inch) nominal gap between the framing members and the wood buck.

C.3.4 Air and/or Water-resistive Barrier Installation

A qualified installer shall install the air barrier materials and accessories [11] following the supplier's installation instructions, including joints for sheet or board material. Any additions, deletions, or deviations to the installation instructions shall be

documented and provided in the test report. The installation shall detail the connection between the steel stud wall and the poured concrete foundation and the steel stud wall and the wood buck, including the metal cladding on the wood buck.

C.3.5 Brick Tie Installation

Install surface mount brick ties [30] equally spaced into the steel studs. Surface mount brick ties shall be installed following the brick tie supplier's instructions and detailed following the air barrier supplier's instructions.

Specimen C.3 Steel Stud Construction

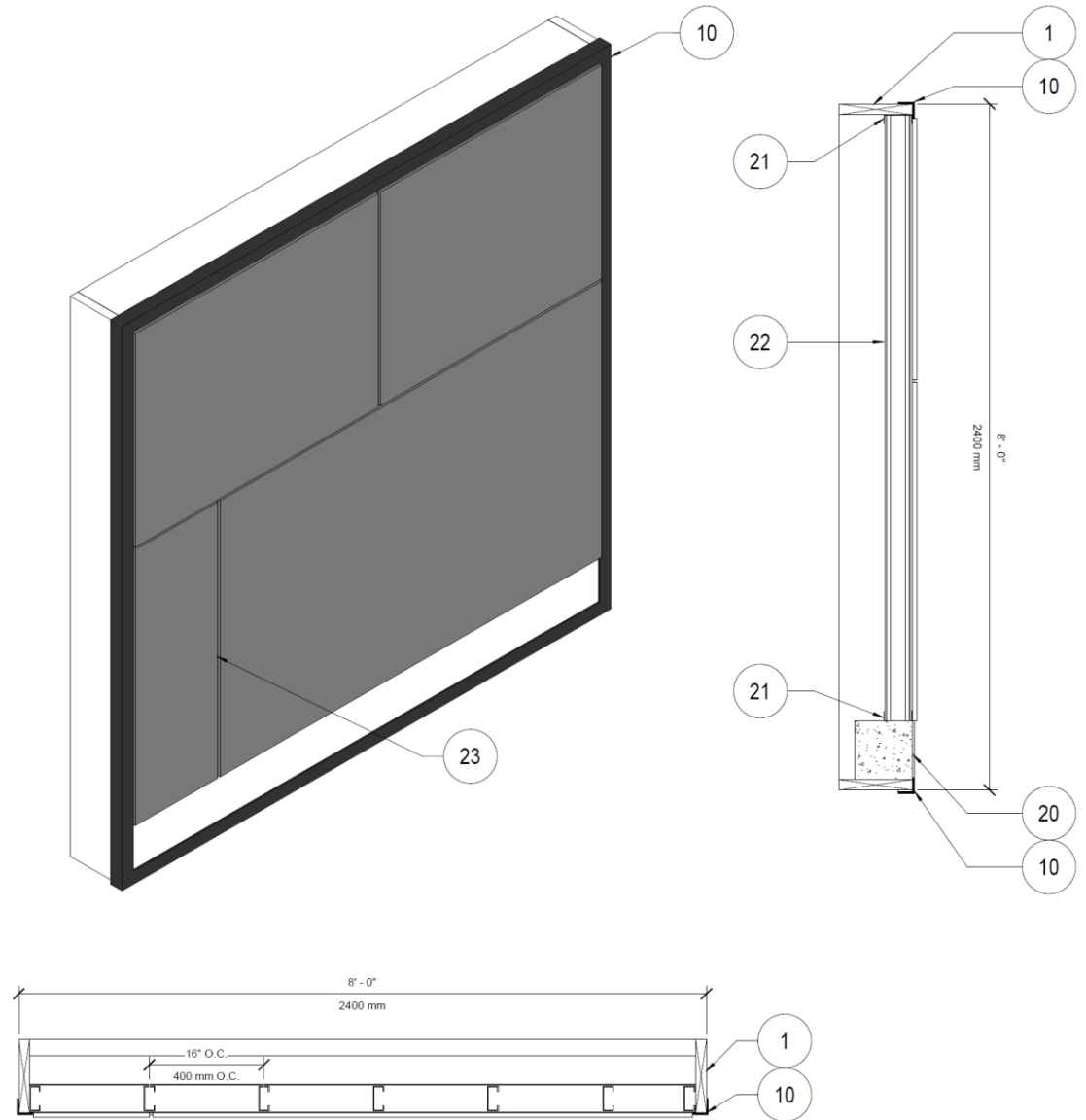

Figure 7
Base Wall: Steel Stud Specimen – Exterior View

Specimen C.3 Steel Stud Construction

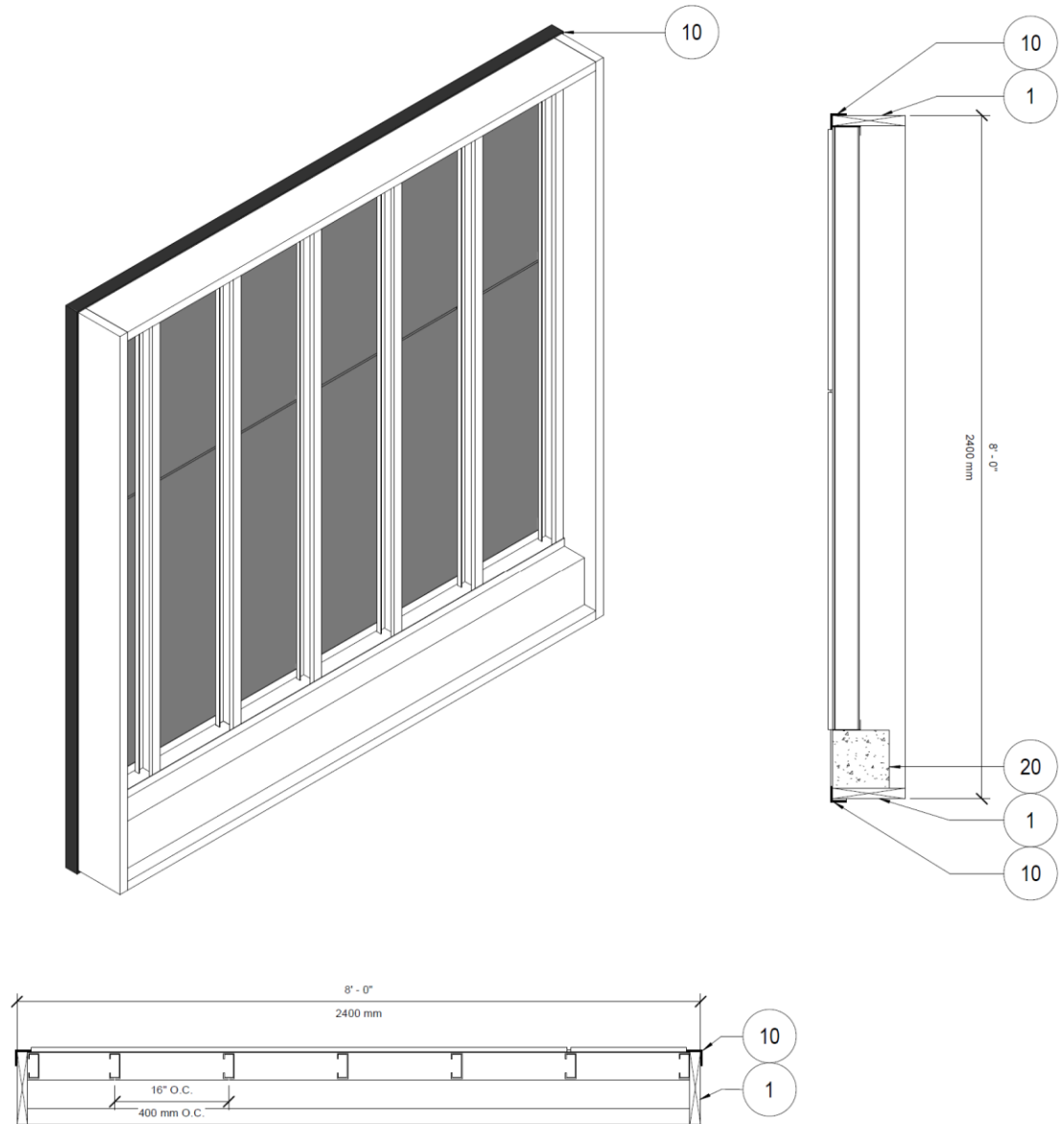

Figure 8
Base Wall: Steel Stud Specimen – Interior View

Specimen C.3 Steel Stud Construction

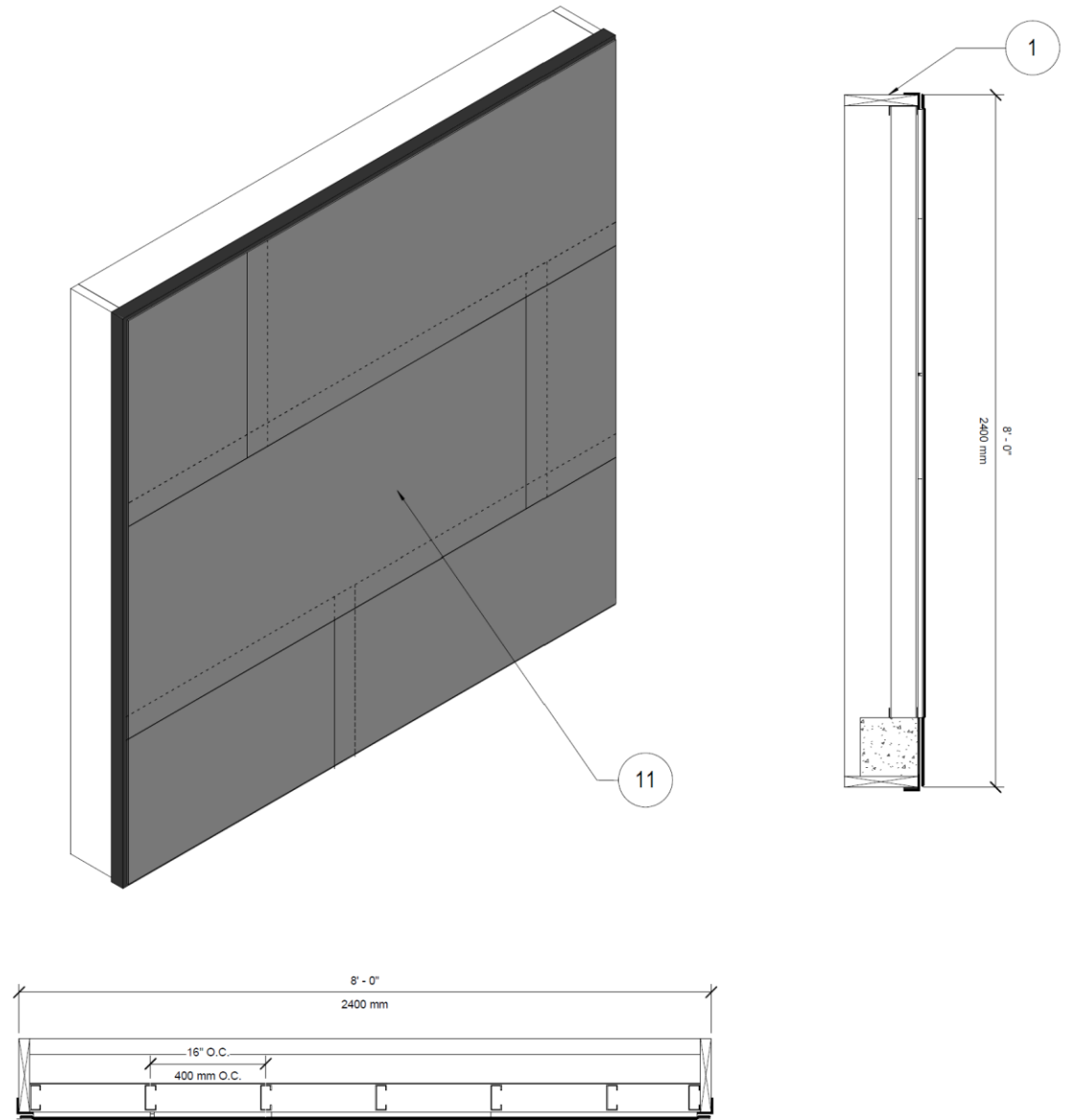

Figure 9
Base Wall: Steel Stud Specimen – Air and/or Water-resistant Barrier Installed

Specimen C.3 Steel Stud Construction

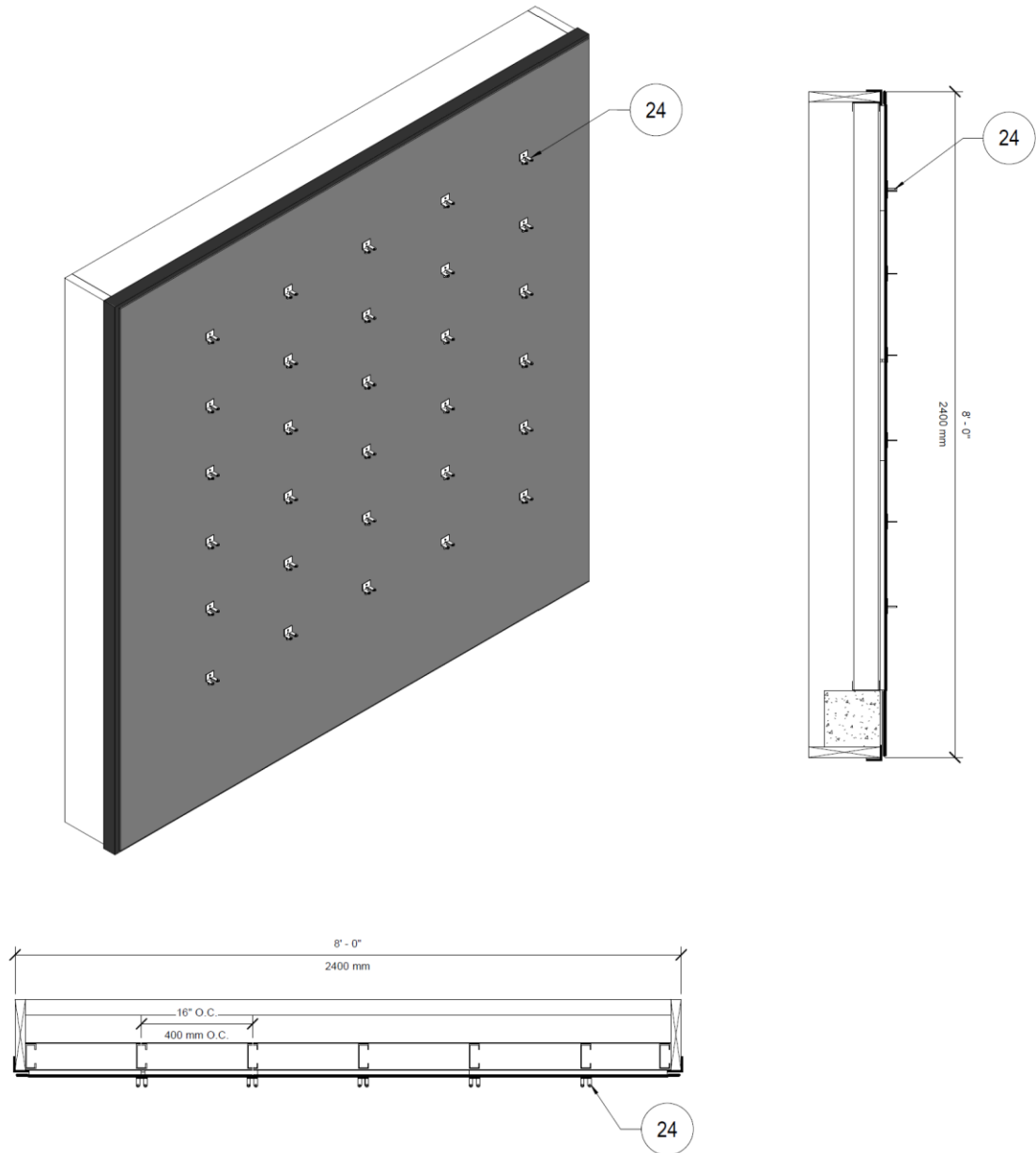

Figure 10
Base Wall: Steel Stud Specimen – Surface Brick Ties
Installed

C.4 Steel Stud Frame Construction Wall Specimen with Penetrations and Terminations

Construct a second specimen following the exact requirements as specified in Annex Section C.4 except brick ties are not required and the wall specimen shall include the following:

- A A window rough opening constructed in the wall measuring 800 mm by 800 mm including:
 - 1. A single 50 mm x 100 mm (2-inch x 4-inch) wood plate installed at the top and bottom of the rough opening between two stud openings.
 - 2. A window blank [13] constructed with outside dimensions of 750 mm by 750 mm (30-inch x 30-inch) nominal, leaving a 12 mm (1/2-inch) space between the rough opening and the blank window.
 - a. The blank window includes a bare, medium density plywood window blank sealed and secured into a rabbeted wood buck.
- B Surface-mounted [14,16] and recessed [15,17] junction boxes.
 - 1. The boxes may be proprietary and form part of the continuity of the proprietary air barrier assembly or conventional boxes that are air sealed with air barrier materials and/or accessories.
 - 2. The published test report shall state the methodology used to seal junction boxes.
- C A PVC pipe [18] with a 38 mm (1 ½-inch) nominal outside diameter.
 - 1. The hole made in the substrate to install the pipe shall be 60 mm (2 ¼-inch) diameter to allowing an approximately 12 mm (1/2 inch) gap between the pipe and the rough opening hole in the sheathing around the pipe.
- D A galvanized steel duct [19] measuring 100 mm by 100 mm (4-inch x 4-inch)

1. The hole made in the substrate to install the duct shall be 125 mm by 125 mm (5-inch x 5-inch) nominal to allowing an approximately 12 mm (1/2 inch) gap between the duct and the rough opening hole in the sheathing around the duct.

Specimen C.4 Steel Stud Construction with Penetrations and Terminations

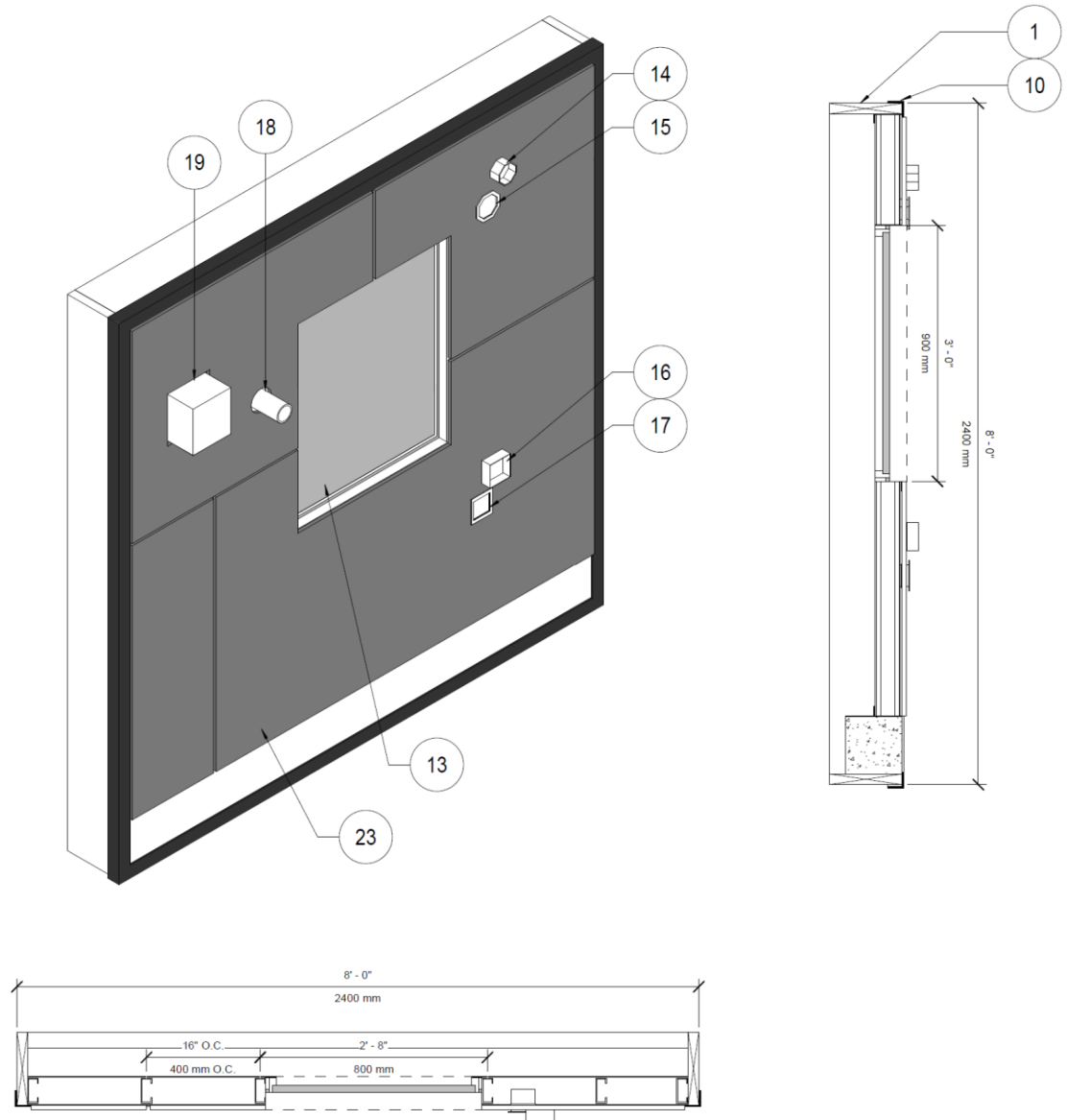

Figure 11
Base Wall: Steel Stud Specimen – Exterior View with Penetrations

**Specimen C.4 Steel Stud Construction with Penetrations
 and Terminations**

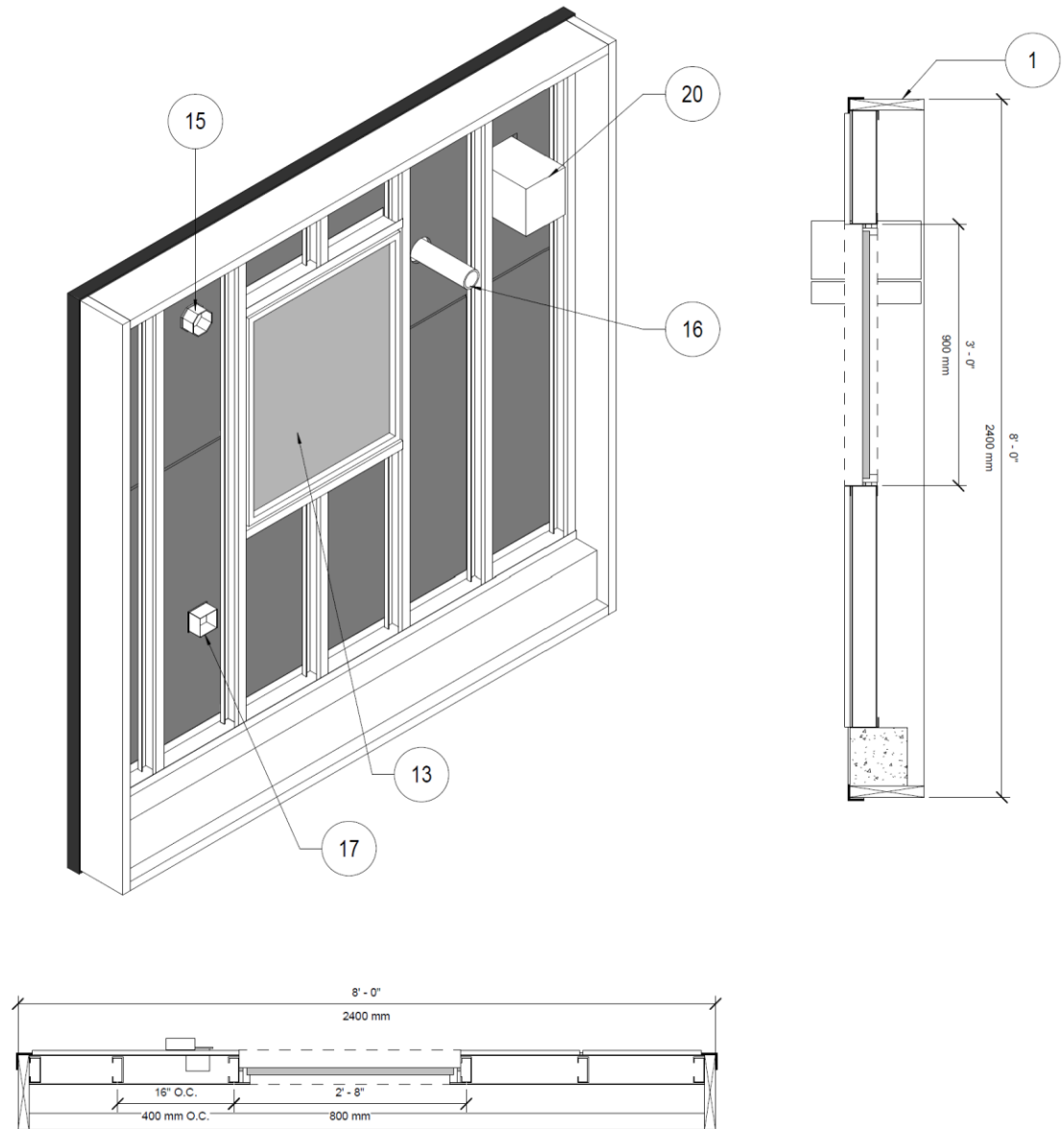

Figure 12
Base Wall: Steel Stud Specimen – Interior View with Penetrations

C.5 CMU Construction Wall Specimen without Penetrations and Terminations

C.5.1 Steel Channel Buck

A steel channel buck is constructed by assembling a steel U channel frame [25] that the specimen wall will be built into it. The corners are to be welded to provide an airtight frame when placed up against the airflow apparatus.

C.5.2 Foundation / Floor Assembly

The base wall has a 200 mm (8 -inch) deep by 200 mm (8-inch) high poured concrete floor [20] installed on the steel channel buck.

C.5.3 Wall Assembly

Construct a CMU wall using medium-density 400 mm x 200 mm x 200 mm (16-inch by 8-inch by 8-inch) blocks. There shall be a 3 mm (1/8 inch) nominal gap between the CMU blocks and the steel buck. If utilizing set in wall eye wire brick ties [26], install equally spaced in the CMU wall, and detail during air and/or water resistive barrier installation.

C.5.4 Air and/or Water-resistive Barrier Installation

A qualified installer shall install the air barrier materials and accessories [11] following the supplier's installation instructions, including joints for sheet or board material. Any additions, deletions, or deviations to the installation instructions shall be documented and provided in the test report. The installation shall detail the connection between the CMU wall and the poured concrete foundation and the CMU wall and the steel buck.

C.5.5 Brick Tie Installation

If using surface-mount brick ties [24] install them equally spaced in the CMU wall. The brick ties shall be installed following the brick tie supplier's instructions and detailed following the air barrier supplier's instructions.

Specimen C.5 CMU Construction

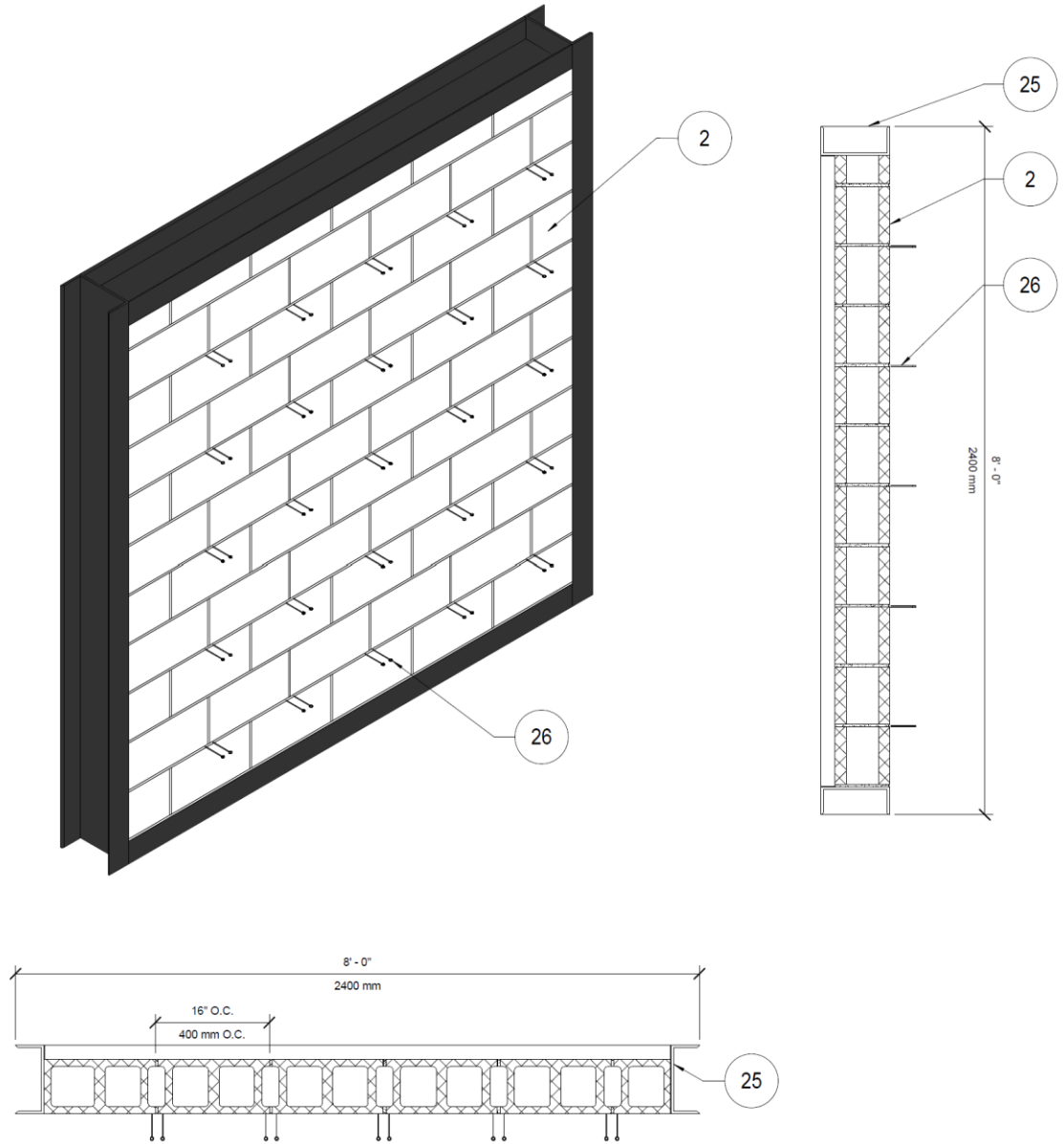

Figure 13
Base Wall: CMU Specimen – Exterior View with Eye Wire
Brick Ties Installed

Specimen C.5 CMU Construction

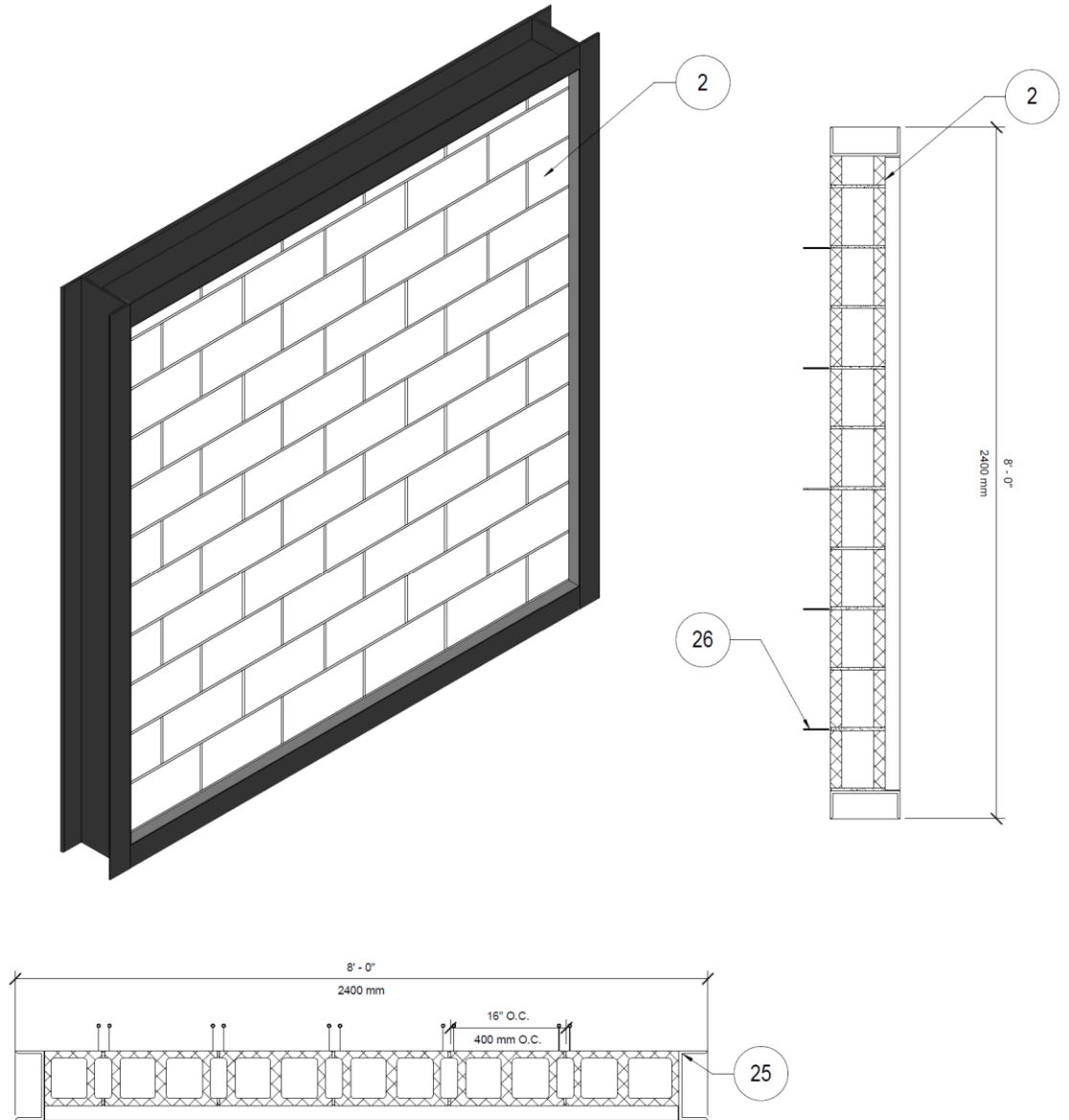

Figure 14
Base Wall: CMU Specimen – Interior View with Eye Wire
Brick Ties Installed

Specimen C.5 CMU Construction

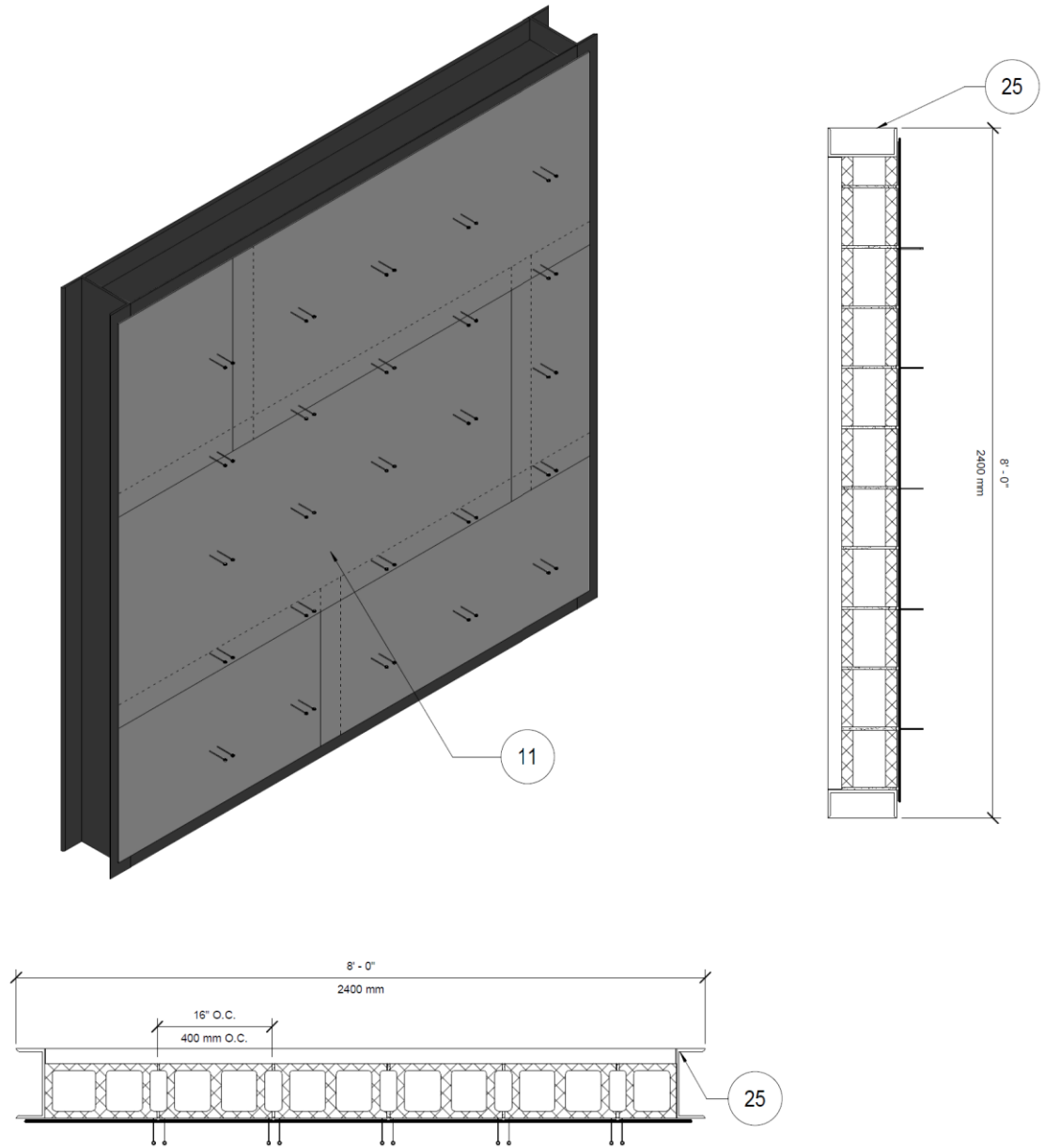

Figure 15
Base Wall: CMU Specimen – Air and/or water-resistive
Barrier Installed

C.6 CMU Construction Wall Specimen with Penetrations and Terminations

Construct a second specimen following the exact requirements as specified in Annex Section C.5 except brick ties are not required and the wall specimen shall include the following

- A A window rough opening constructed in the wall measuring 800 mm by 800 mm including:
 - 1. A single 50 mm x 100 mm (2-inch x 4-inch) wood plate installed at the top and bottom of the rough opening between two stud openings.
 - 2. A window blank [13] constructed with outside dimensions of 750 mm by 750 mm (30-inch x 30-inch) nominal, leaving a 12 mm (1/2-inch) space between the rough opening and the blank window.
 - a. The blank window includes a bare, medium density plywood window blank sealed and secured into a rabbeted wood buck.
- B Surface-mounted [14,16] and recessed [15,17] junction boxes.
 - 1. The boxes may be proprietary and form part of the continuity of the proprietary air barrier assembly or conventional boxes that are air sealed with air barrier materials and/or accessories.
 - 2. The published test report shall state the methodology used to seal junction boxes.
- C A PVC pipe [18] with a 38 mm (1 ½-inch) nominal outside diameter.
 - 1. The hole made in the substrate to install the pipe shall be 60 mm (2 ¼-inch) diameter to allowing an approximately 12 mm (1/2 inch) gap between the pipe and the rough opening hole in the sheathing around the pipe.
- D A galvanized steel duct [19] measuring 100 mm by 100 mm (4-inch x 4-inch)

1. The hole made in the substrate to install the duct shall be 125 mm by 125 mm (5-inch x 5-inch) nominal to allowing an approximately 12 mm (1/2 inch) gap between the duct and the rough opening hole in the sheathing around the duct.

Specimen C.6 CMU Construction with Penetrations and Terminations

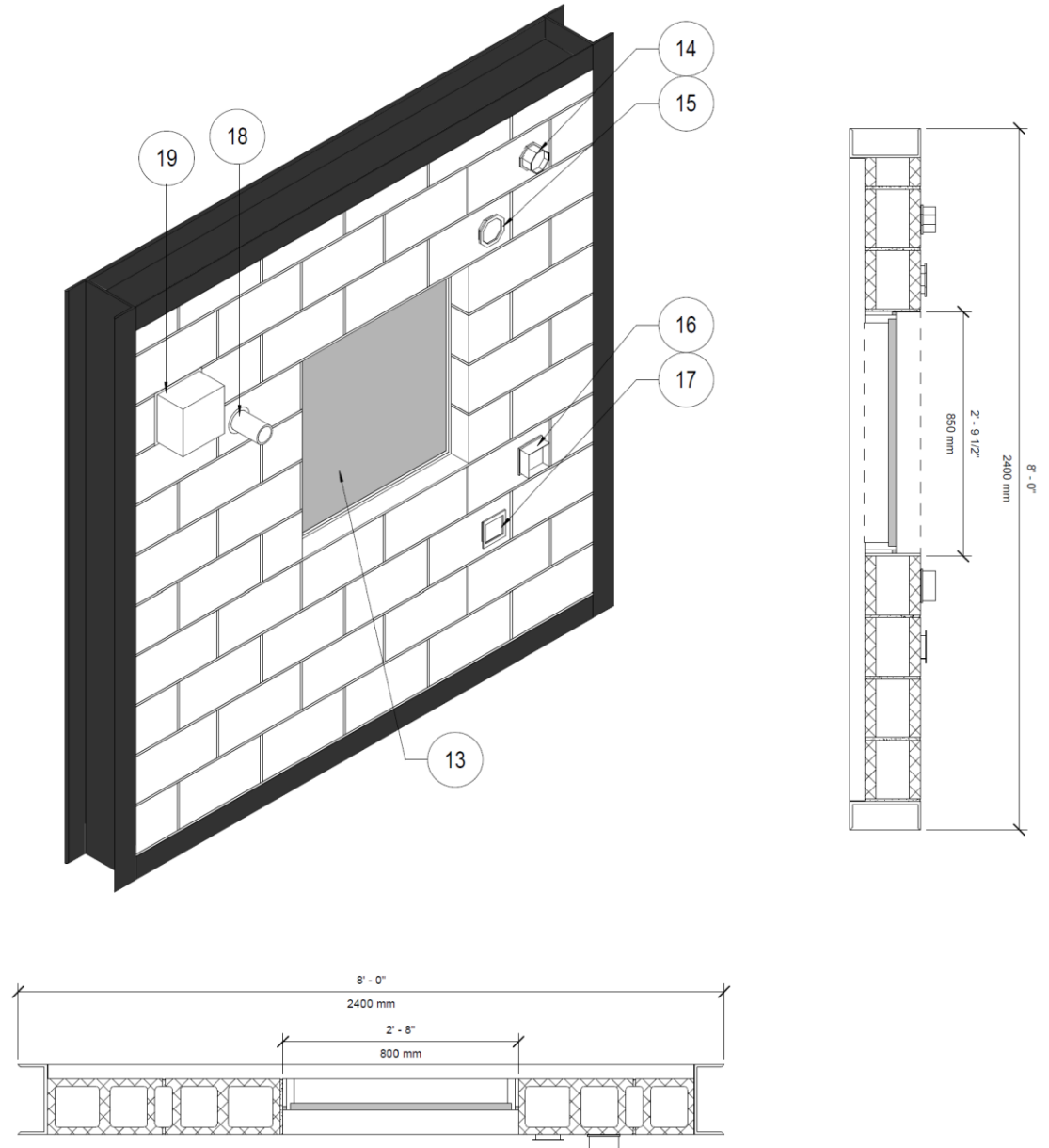

Figure 16
Base Wall: CMU Specimen – Exterior View with Penetrations

Specimen C.6 CMU Construction with Penetrations and Terminations

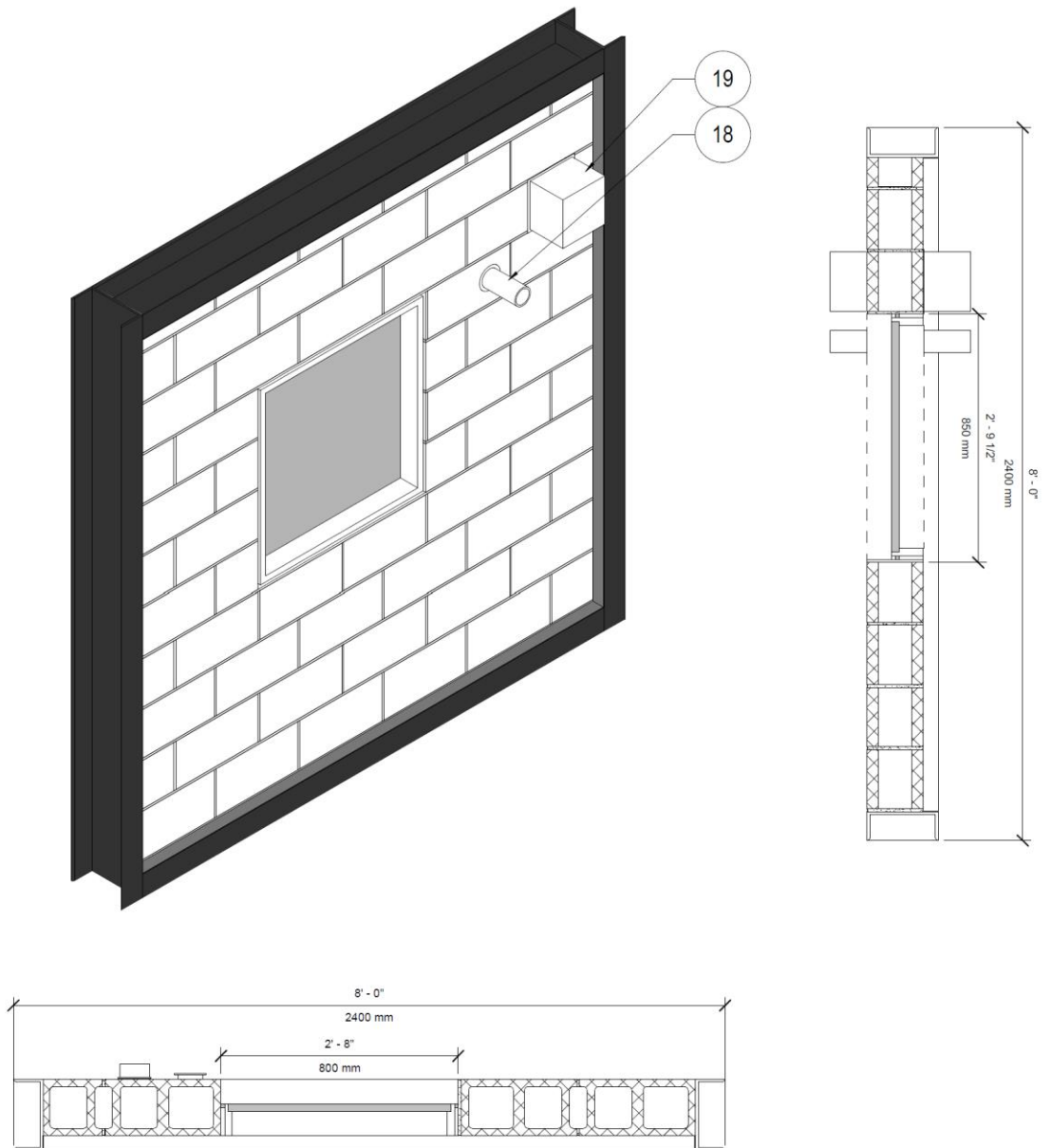

Figure 17
Base Wall: CMU Specimen – Interior View with Penetrations

Specimen C.6 CMU Construction with Penetrations and Terminations

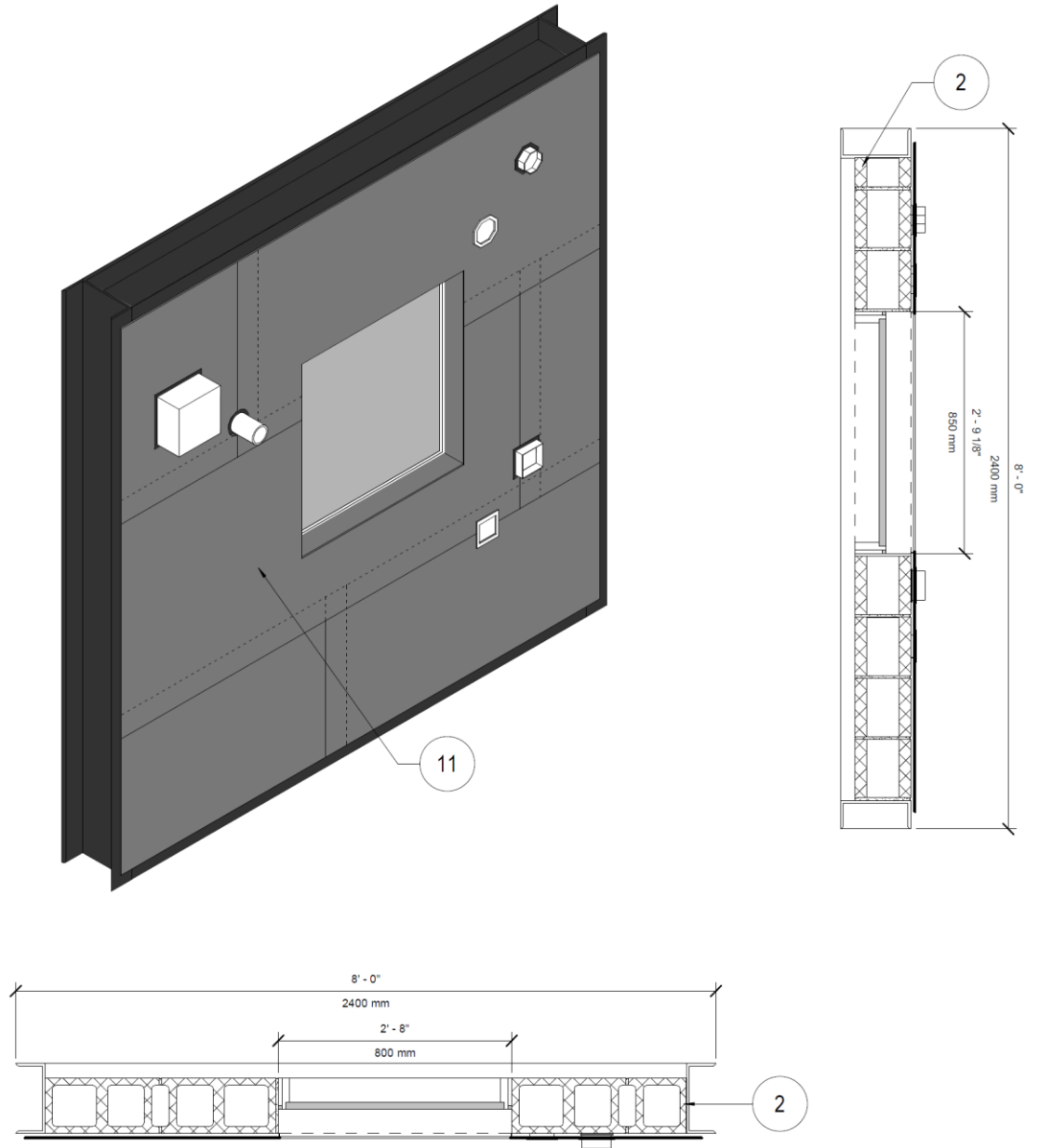

Figure 18
Base Wall: CMU Specimen - Exterior View with Air and/or

Water-resistive Barrier Installed with Penetrations

ABAA Material Evaluation Application Form for Air Barrier Materials, Assemblies & Water Resistive Barriers

MANUFACTURER AND MATERIAL INFORMATION:		
Manufacturer Name:		
Contact Person:	Email Address:	
Address:	City, State, ZIP Code:	
Telephone No.:	Fax No.:	
Website Address:		
Material Name:		
Manufacturer Requested ABAA Listing (Check those that apply):		
<input type="checkbox"/> Air Barrier Material	<input type="checkbox"/> Air Barrier Assembly	<input type="checkbox"/> Water Resistive Barrier
Type of Material (Check one):		
<input type="checkbox"/> Self Adhered Sheet	<input type="checkbox"/> Spray Polyurethane Foam	<input type="checkbox"/> Liquid Applied Membrane
<input type="checkbox"/> Mechanically Fastened Wrap	<input type="checkbox"/> Boardstock	

PLEASE NOTE: All submittal documentation will be reviewed to the ABAA Process for Approval of Air Barrier Materials, Components & Assemblies for completeness and compliance to requirements when received from the manufacturer.

The ABAA office will correspond with the manufacturer in regards to clarification or missing items once the initial review is complete.

Upon receipt and review of the submitted information, it will be documented and organized by the ABAA office who then will provide a review of the documentation submitted and provide comments back in an itemized checklist.

From date of receipt of materials, an initial completeness / submittal checklist will be reviewed within three weeks of the receipt of the final documentation required.

If no further information is required, a technical review will be completed by the ABAA office in three weeks.

The completeness and consistency review by the ABAA office shall be completed within ten weeks from the date of receipt from the ABAA office.

A written response by ABAA will be submitted to the manufacturer within one week of the review

Requirements for listing of Air Barrier Materials and Assemblies

See the Air Barrier Association of America Process for Approval of Air Barrier Materials and Assemblies for the requirements of listing a air barrier material and/or assembly.

Requirements for listing of Water Resistive Barriers

See Air Barrier Association of America Process for Approval of Water Resistive Barriers for the requirements of listing a water resistive barrier.

NAME (Please print): _____ Date: _____

NAME (Signature): _____

If you have any questions, please contact us at 1.866.956-5888 or abaa@airbarrier.org. Thank You.

MUTUAL NONDISCLOSURE AGREEMENT

This NONDISCLOSURE AGREEMENT, dated as of _____, 20____
is between

Air Barrier Association of America, Inc.

(hereinafter "ABAA")

having its principal place of business at
1600 Boston-Providence Hwy, Walpole, MA, 02081

and

(hereinafter "Disclosing Party")

having its principal place of business at

BACKGROUND

- A. The Air Barrier Association of America Inc. (ABAA) includes references to different manufacturer's materials on the website of ABAA and in various documents produced by ABAA.
- B. To include a specific material from a manufacturer, ABAA requires a copy of test reports or other technical information that is proprietary to that manufacturer; and
- C. Each of the parties hereto wishes to ensure that all such trade secrets, know-how and confidential information are treated in a strictly confidential manner by the party receiving such information.

TERMS

NOW THEREFORE, in consideration of the premises and covenants contains herein, and intending to be legally bound hereby, the parties hereto agree as follows:

1. Confidential Information. The confidential information disclosed under this Agreement is described as Disclosing Party's business and technical information that is not generally known to the public and includes, but is not limited to, product specifications and designs, technical data, manufacturing materials, production machinery, plant layout and design,

quality assurance methods, discoveries, inventions, know-how, copyrights, concepts and ideas, whether patentable or not, including without limitation the nature and result of research, development and manufacturing, computer software, source and object codes, flowcharts, algorithms, report forms, compilers, design concepts and related documentation, manuals, business operations, pricing and cost data, customer lists, supplier lists, marketing information, marketing plans, financial information, product samples and any and all other records and information (collectively, "Confidential Information"). Any information disclosed by Disclosing Party to ABAA, whether written or oral, in whatever form or medium shall be considered Confidential Information subject to Section 5.

2. Nondisclosure. Except with the prior written consent of the Disclosing Party or as specifically provided herein, ABAA shall not disclose or permit the disclosure to any third party any Confidential Information.
3. Restricted Use of Confidential Information. ABAA shall limit the dissemination of any Confidential Information to its affiliates / service providers and their representatives who need to know such information and who are informed of their obligation to maintain the confidential nature of such information solely for the purposes of assisting ABAA fulfill its function. ABAA agrees to be responsible for any breach of their Agreement by its affiliates or service providers.
4. Permitted Exception. ABAA shall not be under any obligation under this agreement with respect to any Confidential Information of the Disclosing Party that:
 - (a) is or becomes generally available to the public other than as a result of a breach of this Agreement by the ABAA or any of its affiliates or representatives;
 - (b) is known to the ABAA or any of its affiliates or representatives at the time of disclosure;
 - (c) was received by the ABAA or any of its affiliates after the time of disclosure hereunder on a non-confidential basis from a third party who had a legal right to make use of such Confidential Information.In order to rely on any of the foregoing permitted exceptions, the ABAA shall immediately advise the Disclosing Party upon receipt of any Confidential Information, that a permitted exception applies and shall provide reasonable details of such permitted exception.
5. No Grant of License. Nothing in this Agreement shall be constructed as granting or implying any right or license to use any Confidential Information disclosed hereunder, and all Confidential Information disclosed or otherwise acquired by the ABAA shall remain the property of the Disclosing Party.
6. Return of Information. Upon the discontinuance of this agreement, ABAA shall immediately discontinue the reference of these materials and upon the request of the Disclosing Party, promptly, but at least within ninety (90) days of request, return or destroy all written or other tangible materials that contains any Disclosing Party's Confidential Information that were made available or supplied to ABAA by the Disclosing Party (including all copies or reproductions of such materials). Any materials prepared by ABAA or any of its affiliates or representatives that include Confidential Information or that contain references to the Confidential Information shall be destroyed, and such destruction shall be certified in writing to the Disclosing Party by an authorized representative of the ABAA who has supervised the destruction.
7. Test Materials and Samples. All test materials and samples furnished by the Disclosing Party shall remain the property of the Disclosing Party. In the event that ABAA performs or has performed tests and experiments on the materials or samples provided by the Disclosing Party, ABAA shall provide a copy of the tests reports to the Disclosing Party.

All test and performance results shall be Confidential Information subject to the terms of this Agreement.

8. Disclosure Required by Law. In the event that the ABAA becomes legally compelled under applicable law or court order to disclose any Confidential Information, ABAA agrees to provide the Disclosing Party with prompt notice of such request(s) so that the Disclosing Party may seek an appropriate protective order or other appropriate remedy and/or waive ABAA's compliance with the provisions of this agreement. If the Disclosing Party has not obtained a protective order or other appropriate remedy within a reasonable period of time after notice by the ABAA, or if the Disclosing Party waives compliance with the provisions of this Agreement, ABAA agrees to furnish only that portion of the Confidential Information that, in the reasonable opinion of ABAA's counsel, is legally required to be furnished.
9. Relationship of Parties. It is not the intention of the parties to this Agreement to create, nor shall this Agreement be constructed as creating any joint venture, partnership or agency relationship between the parties so as to render either party liable to the other party for anything more than the performance of its respective obligations hereunder.
10. Equitable Relief. ABAA acknowledges that its unauthorized disclosure or use of the Disclosing Party's Confidential Information will have a material adverse effect on the disclosing party for which damages may be difficult to ascertain. ABAA therefore agrees that in addition to and not in lieu of any other rights or remedies the Disclosing Party may have, the Disclosing Party may be entitled to equitable relief, including injunctive relief and specific performance, in the event of any breach of this Agreement.
11. Other Remedies. Each party retains all rights and remedies afforded under the patent and other statutory laws of any relevant jurisdiction and of the common law, including without limitation any laws designed to protect proprietary or confidential information.
12. No Assignment. ABAA shall not assign any of its rights or obligations hereunder, and any such purported assignment shall be null and void.
13. Notices. All notices or communications required or permitted under this Agreement shall be in writing and shall be sent by registered or certified mail, postage prepaid, or by telecopier, or recognized overnight carrier, to the intended recipient at the address and attention designated above or to such other address or attention as the ABAA may have designated in writing. Any such notice or communication shall be deemed delivered as follows: if hand delivered, on the day so delivered; if mailed, three business days after the date so mailed; if telecopied, upon written confirmation by the sending machine of effective transmission or upon telephone confirmation of receipt (provided that a confirmation copy is sent by recognized overnight carrier); and if sent by recognized overnight courier, the next business day.
14. No Waiver. No waiver of any provision, breach, or default under this Agreement shall be deemed a waiver of any subsequent provision, breach, or default, nor shall any waiver constitute a continuing waiver.
15. Binding Effect. This Agreement shall be binding upon and inure to the benefit of the parties hereto and their respective successors and permitted assigns.
16. Entire Agreement; Amendments. This Agreement sets forth the entire understanding between the parties hereto with respect to the subject matter hereof and supersedes all prior agreements or undertakings, whether written or oral. This Agreement may not be amended, supplemented or rescinded except by a written instrument duly executed by each of the parties hereto.

17. Term and Termination. This Agreement shall expire or terminate 30 days following written notification from either party to the other party. Each party agrees that all of its obligations undertaken under this agreement and all of its rights and remedies shall survive and continue with respect to Confidential Information disclosed under this Agreement after termination or expiration of this Agreement for any reason: (a) with respect to Confidential Information, for a period of ten (10) years from the date of its disclosure under this Agreement; and (b) with respect to trade secrets, for so long as such information retains its status as a trade secret under applicable law.
18. Execution. This Agreement shall be executed in duplicate and shall be effective as of the date first written above.
19. Counterparts. This Agreement may be executed in any number of counterparts, each of which shall be deemed an original and all of which, taken together, shall constitute one and the same instrument. This Agreement shall become binding only when each party has executed and delivered to the other party hereto one or more counterparts.
20. Governing Law. This Agreement shall be governed by and constructed and enforced in accordance with the laws of the Commonwealth of Massachusetts, without giving effect to its principles or conflicts of law.

IN WITNESS OF WHEREOF, the parties hereto have caused this Agreement to be executed in duplicate as of the date first written above.

**AIR BARRIER ASSOCIATION OF
AMERICA, INC.**

“Manufacturer Licensee”

Per: _____

Per: _____

Name: _____

Name: _____

Title: _____

Title: _____

Date: _____

Date: _____

and

Per: _____

Name: _____

Title: _____

Date: _____

THIS AGREEMENT is made with effect as of _____, 20_____
(the "Effective Date").

between

Air Barrier Association of America, Inc.

(hereinafter "ABAA")

having its principal place of business at
1600 Boston-Providence Hwy, Walpole, MA, 02081

and

(hereinafter "Manufacturer Licensee")

having its principal place of business at

WHEREAS, ABAA is a body dedicated to setting high standards for on-going professional practice in the air barrier system industry through the ABAA Quality Assurance Program ("Air Barrier QAP") and licenses qualifying manufacturers, contractors, and installers to use its Certification Mark; and

WHEREAS, use of the ABAA Certification Mark symbolizes that parties have met ABAA's standards of practice and specifications; and

WHEREAS ABAA has agreed to grant a non-exclusive license to the Manufacturer Licensee to use its Certification Mark on the terms and conditions as set forth in this Agreement, once the Manufacturer Licensee has been approved as an Evaluated Manufacturer;

NOW THEREFORE, in exchange for good and valuable consideration, the receipt and sufficiency of which the parties hereby acknowledge the parties agree as follows:

1. DEFINITIONS

The following terms shall have the meanings set forth below:

- 1.1. **"Evaluated Manufacturer"** is a corporation that manufactures or sells air barrier materials who has agreed to comply with the ABAA Air Barrier material approval process (ABAA having agreed to the manufacturer's use of same) in connection with the manufacture of its materials. In order to be an Evaluated

Manufacturer Licensee initials: _____

Air Barrier Association of America, Inc. initials: _____

Manufacturer, such person must also have entered into a licensing agreement with ABAA with respect to the use of the Certification Mark.

- 1.2. **“Air Barrier QAP”** is the Commercial Air Barrier Systems Professional Contractor Quality Assurance Program Manual.
- 1.3. **“Certification Mark”** means collectively AIR BARRIER ASSOCIATION OF AMERICA ABAA ACCREDITED (and design), Registration No 4206480, AIR BARRIER ASSOCIATION OF AMERICA ABAA CERTIFIED (and design), Registration No 4354304, and AIR BARRIER ASSOCIATION OF AMERICA ABAA EVALUATED (and design), Registration No. 4335209 set forth in Schedule "A" hereto and any related marks that ABAA informs Manufacturer Licensee of and which Manufacturer Licensee is authorised to use as an Evaluated Manufacturer.
- 1.4. **"Term"** has the meaning set forth in paragraph 2.1 below.

2. GRANT AND TERM

- 2.1. This Agreement shall commence on the Effective Date indicated above and shall continue until terminated by ABAA and/or the Manufacturer Licensee in accordance with paragraph 7 hereof (the "Term").
- 2.2. In consideration of the approval of Manufacturer Licensee as an Evaluated Manufacturer and subject to the terms and conditions of this Agreement, ABAA hereby grants to the Manufacturer Licensee the non-exclusive right and license to use the Certification Mark in the United States of America during the Term for the materials which qualify under the Air Barrier QAP.
- 2.3. Excepting its subsidiary companies, the Manufacturer Licensee shall not be entitled to sub-license to third parties any of its rights or obligations under this Agreement without the prior, written consent of ABAA.
- 2.4. The parties each hereby confirm to the other that it has full power and authority to enter into this Agreement, and that in doing so (or carrying out any of its obligations hereunder) it is not violating the rights of any third party or any agreement by which it is bound.

3. MANUFACTURER LICENSEE

True and Accurate Representations

- 3.1. The Manufacturer Licensee represents and warrants that all information it has given to ABAA (or its employees, agents or designates) under this Agreement, and for licensing purposes under or in connection with the Air Barrier QAP, is believed to be true and correct.

Manufacturer Licensee initials: _____

Air Barrier Association of America, Inc. initials: _____

Proprietary to ABAA

- 3.2. The Manufacturer Licensee acknowledges that it has been advised that the Air Barrier QAP is a proprietary program of ABAA, and it will not challenge such proprietary right during the Term or thereafter. The Manufacturer Licensee shall not use the Air Barrier QAP (including without limitation any documents or materials relating thereto) for any purpose other than to carry out the terms of this Agreement. The Manufacturer Licensee may not use the Air Barrier QAP for any other purposes nor may it, copy or distribute the Air Barrier QAP documentation to third parties other than subsidiary companies, who have a need to know, without the prior, written consent of ABAA. The obligations set out in this paragraph survive the expiration or termination of this Agreement.

Compliance with Obligations

- 3.3. The Manufacturer Licensee shall comply with the manufacturer's obligation in the Air Barrier QAP for the duration of the Term.
- 3.4. The Manufacturer Licensee acknowledges and agrees that the Air Barrier QAP (including without limitation, the materials, systems, programs, standards, requirements and methods relating thereto) may be amended from time to time by ABAA, and ABAA shall provide the Manufacturer Licensee with reasonable notice in writing of any such amendments. The Manufacturer Licensee shall use reasonable commercial efforts to comply with any new obligation for manufacturers section of the Air Barrier QAP.

Quality Control (Products and Licensing Requirements)

- 3.5. The Manufacturer Licensee agrees to maintain itself as a member in good standing with the ABAA. The Manufacturer Licensee agrees that its license to use the Certification Mark may be suspended and/or terminated at the sole and unilateral discretion of the ABAA if the Manufacturer Licensee fails to maintain the membership in good standing with ABAA.

Additional Requirements - Conduct

- 3.6. The Manufacturer Licensee will not provide or otherwise communicate, directly or indirectly, to any third parties any information that it knows to be incorrect or disparaging information concerning ABAA and/or the Air Barrier QAP.

Regulatory Requirements

- 3.7. The Manufacturer Licensee shall be responsible for obtaining all licenses, permits, consents and approvals which are required for manufacturers of materials by all applicable governmental or other regulatory authorities. If and when requested by ABAA, the Manufacturer Licensee shall provide ABAA with

Manufacturer Licensee initials: _____

Air Barrier Association of America, Inc. initials: _____

copies of all such licenses, permits, consents, or approvals within a reasonable time.

- 3.8. The Manufacturer Licensee agrees to abide by all federal, state, and local regulations applicable to the manufacture, transportation, storing, handling, and installation of air barrier materials, including without limitation all applicable health and safety regulations.

4. MANUFACTURER LICENSEE'S USE OF CERTIFICATION MARK

- 4.1. Subject to any requirements necessitated by complying to 3.7 above, the Manufacturer Licensee agrees to use no other Certification Mark for air barriers other than the Certification Mark to identify it as an Evaluated Manufacturer or its product as an evaluated material, assembly, or system. The Manufacturer Licensee will use the Certification Mark only in the manner expressly directed and approved by ABAA and only in association with the manufacture of barrier materials, assemblies, or systems.
- 4.2. The Manufacturer Licensee shall timely: (a) notify ABAA in advance and in writing of its intent to use or distribute materials, documents, packaging, advertisements, and/or products that bear the Certification Mark; and (b) provide ABAA with copies of same. ABAA will respond to such submissions within 30 days from the date of submission. Should ABAA reasonably object to any uses of the Certification Mark, the Manufacturer Licensee shall promptly cease use of same in accordance with ABAA's demand. The Manufacturer Licensee will use the Certification Mark only in the manner authorized under this Agreement and only in association with evaluated products in the air barrier industry.
- 4.3. No advertising by the Manufacturer Licensee shall contain any statement or material related to ABAA which may, in the reasonable judgment of ABAA, contain objectionable language, be in bad taste or be inconsistent with ABAA's public image as a first class, professional organization that exercises high standards of safety, conduct, and professionalism in the air barrier industry.
- 4.4. The Manufacturer Licensee agrees not to use the Certification Mark in a manner calculated to represent that the Manufacturer Licensee is the owner of such mark or that the Manufacturer Licensee is something other than an accredited user of the Certification Mark. The Manufacturer Licensee further acknowledges that it has been advised that ABAA's Certification Mark is the sole and exclusive property of ABAA, its successors and assigns, and agrees that during the term of this Agreement and thereafter it will not dispute or contest the validity or enforceability of the Certification Mark, including without limitation any amendments thereto or future marks forming part of the Certification Mark, nor will the Manufacturer Licensee counsel, procure, or assist any third party in doing the same, directly or indirectly. The Manufacturer Licensee shall not during the Term of this Agreement or thereafter register or attempt to register, directly or indirectly, any business or trade name or trade-mark that is confusingly similar with the Certification Mark.

Manufacturer Licensee initials: _____

Air Barrier Association of America, Inc. initials: _____

- 4.5. The Manufacturer Licensee agrees that any and all rights that may be acquired by the use of the Certification Mark by Licensee shall, where appropriate, inure to the benefit of ABAA as licensor.
- 4.6. The Manufacturer Licensee agrees to forthwith for the term of the agreement provide all necessary information and to execute all papers reasonably requested by ABAA to affect the registration, maintenance or defense of the Certification Mark or to renew same.
- 4.7. The Manufacturer Licensee shall promptly notify ABAA of any apparent or actual infringement or challenge to ABAA's Certification Mark, and the Manufacturer Licensee will not communicate with any other person other than ABAA, unless legally obliged to the contrary, in connection with any such infringement, challenge, or claim. The Manufacturer Licensee shall cooperate with ABAA (and reasonably assist ABAA, upon request) with respect to the prosecution of any litigation relating to such infringement or the challenging of the Certification Mark. ABAA shall, in its sole discretion, make any and all decisions with respect to such litigation (or the settlement of any disputes) and ABAA shall be solely entitled to any awards on account of such litigation. ABAA shall indemnify and hold Manufacturer Licensee harmless from and against all claims, losses, judgments, liabilities, decrees, costs and reasonable expenses arising out of, related to, or resulting from, any actual infringement of the Certification Mark and the use thereof by the Manufacturer Licensee.

5. OWNERSHIP AND MARKING

- 5.1 The Manufacturer Licensee acquires no right, title or interest in or to the Certification Mark except as expressly provided in this Agreement. The Manufacturer Licensee shall at all times observe the requirements with respect to trade-mark notices and other forms of marking with respect to the Certification Mark as ABAA may from time to time, in its sole discretion, direct and communicate to the Manufacturer Licensee. The Manufacturer Licensee shall, when using the Certification Mark, so describe the Certification Mark to indicate clearly that it is owned and controlled by ABAA and that it is being used by the Manufacturer Licensee under license.
- 5.2 The Manufacturer Licensee shall ensure that any and all checks, letterhead, contractual documents, or writings of any nature, will not directly or indirectly state or suggest that ABAA is responsible or liable in any way for the obligations or responsibilities of the Manufacturer Licensee.

6. ABAA'S OBLIGATIONS

- 6.1. Provided that the Manufacturer Licensee meets its obligations under this Agreement, upon written request, ABAA will provide the Manufacturer Licensee

Manufacturer Licensee initials: _____

Air Barrier Association of America, Inc. initials: _____

with an ABAA Certificate, which will show the Manufacturer Licensee as being in good standing.

7. BREACH AND TERMINATION

- 7.1. This Agreement may be terminated by the Manufacturer Licensee at any time by providing ABAA with one month advance written notice of its intention to terminate this Agreement.
- 7.2. ABAA may terminate this Agreement by providing three months advance written notice to the Manufacturer Licensee.
- 7.3. ABAA can suspend or terminate Manufacturer Licensee's rights granted hereunder if the Manufacturer Licensee fails to cure or commence action to cure any material breach of its obligations under this Agreement, or of any requirements of the Air Barrier QAP with deliberate speed (and in no event later than 30 days after receiving notice of such material breach).
- 7.4. Without limiting the generality of the foregoing, the ABAA can deem the Manufacturer Licensee to be in default under this Agreement in the event that:
 - a. the Manufacturer Licensee is in default of any of its material obligations under this Agreement or the applicable licensing standards under the Air Barrier QAP and has failed to cure such material default or commences action to cure within 30 days of receipt of notice from ABAA;
 - b. the Manufacturer Licensee files a petition in bankruptcy in any jurisdiction, becomes a debtor in a bankruptcy proceeding, makes a general assignment for the benefit of creditors, if a bankruptcy petition is filed against the Manufacturer Licensee, if Manufacturer Licensee shall be declared or adjudicated bankrupt, if a liquidator, trustee in bankruptcy, custodian, receiver, receiver and manager or any other officer with similar powers shall be appointed of or for the Manufacturer Licensee, or if the Manufacturer Licensee shall commit any act of bankruptcy or insolvency or consents to the institution of such appointment or proceedings or admits in writing its inability to pay debts as they become due;
 - c. the Manufacturer Licensee transfers or attempts to transfer this Agreement or any rights hereunder to any person other than a subsidiary company without the prior written consent of ABAA.
- 7.5. Should ABAA elect to suspend rather than terminate this Agreement, ABAA shall give the Manufacturer Licensee an opportunity to cure its default. To that end, ABAA shall notify the Manufacturer Licensee in writing of the suspension of this Agreement, identify the default to be remedied, and specify the time granted to the Manufacturer Licensee to correct said default. If the Manufacturer Licensee fails to correct said default within the specified time, ABAA may, in its sole discretion, terminate, this Agreement.

Manufacturer Licensee initials: _____

Air Barrier Association of America, Inc. initials: _____

- 7.6. In the event of a suspension, or should this Agreement be terminated for any reason, the Manufacturer Licensee shall promptly:
- a. Except as provided in subparagraph (b) below, cease to use the Certification Mark(s) and the Air Barrier QAP, in any manner and for any purpose whatsoever;
 - b. remove the Certification Mark(s) and any reference to the Air Barrier QAP from any and all materials, products, or systems including without limitation packaging, signs and advertisements, under its custody or control upon which the Certification Marks or reference to the Air Barrier QAP appears, provided, however manufacturer, for a period of twelve (12) months following termination, may (i) sell pre-existing inventory bearing the Certification Mark, and (ii) use and distribute all pre-existing brochures packaging, product data sheets, marketing bulletins and other product literature and marketing materials in connection with the sale, marketing and promotion of Manufacturer Licensee's products.
 - c. pay to ABAA all fees due and payable prior to receipt of the notice of termination or suspension; and
 - d. cease to and thereafter not hold itself out, directly or indirectly, as a licensee of ABAA or the Air Barrier QAP Licensing Organization.
- 7.7. The Manufacturer Licensee agrees that the requirements set forth in paragraph 7 are reasonable and necessary to protect the integrity of the Certification Mark and those requirements are enforceable by injunction, including without limitation interlocutory injunction, by any court of competent jurisdiction.

8. INDEMNITY AND RELEASE

- 8.1. Other than the indemnity and defense in Section 4.7, the Manufacturer Licensee acknowledges that neither ABAA, nor its directors, officers, agents, or employees shall be responsible to the Manufacturer Licensee or any third party for any loss, cost, damage, liability, or claim howsoever occasioned, whether by act, omission, failure to act, negligence, or willful conduct, in respect of the services, materials or products of the Manufacturer Licensee, or the use and delivery of the Air Barrier QAP in connection therewith. The Manufacturer Licensee shall defend and hold ABAA, its directors, officers, agents, and employees harmless from and indemnify them for any claims or damages resulting from Manufacturer Licensee's materials except to the extent such claims or damages result from, relate to, or arise out of the Certification Mark or the use thereof by the Manufacturer Licensee.
- 8.2. Without limiting the generality of the foregoing, ABAA shall not be obligated or liable to the Manufacturer Licensee for any injury or death of any person or

Manufacturer Licensee initials: _____

Air Barrier Association of America, Inc. initials: _____

damage to any property caused by or relating to the materials, products or systems manufactured, used, or provided by the Manufacturer Licensee.

- 8.3. The Manufacturer Licensee covenants and agrees that, except for the indemnity set forth in Section 4.7 above of this Agreement, in no event shall ABAA, or any authorized representative, be liable for any loss, cost or damage that may be suffered by the Manufacturer Licensee by virtue of its license or the suspension or termination of its license.
- 8.4. Neither party will be liable to the other party under any cause of action, whether in contract, tort, or otherwise, for any indirect, special, incidental, consequential, or punitive damages, even if the party has been advised of the possibility of such damages.

9. GENERAL

- 9.1. The Manufacturer Licensee is and will at all times remain an independent contractor and is not and shall not represent itself to be the agent, employee, joint venturer, or partner of ABAA. The Manufacturer Licensee shall neither represent nor engage in any act that could establish an apparent relationship of agency, employment, joint venture or partnership with ABAA and ABAA shall not be bound in any manner whatsoever by any agreements, warranties or representations made by the Manufacturer Licensee to any other person or with respect to any other action of the Manufacturer Licensee.
- 9.2. This Agreement shall be interpreted and construed in accordance with the laws of the United States and Commonwealth of Massachusetts to the extent applicable hereto.
- 9.3. All notices under this Agreement shall be in writing and shall be sent by prepaid courier or certified post or served personally. If sent by courier or certified post, service shall be deemed to have been made on the second day following delivery of the notice by the transmitting party to the courier or U.S. Post. Unless changed in writing, ABAA's address for the purpose of notice is: 1600 Boston-Providence Hwy, Walpole, MA 02081; for the Manufacturer Licensee, it will be the address listed at the top of this document, unless ABAA is otherwise notified in writing during the term of this Agreement.
- 9.4. This Agreement represents the entire agreement between the parties and no representation, warranty or condition shall apply hereto unless expressed herein in writing. This Agreement may not be amended except by written agreement executed by the parties.
- 9.5. In this Agreement, the masculine singular includes the feminine singular, the neuter and all plural forms thereof.

Manufacturer Licensee initials: _____

Air Barrier Association of America, Inc. initials: _____

- 9.6. The headings herein are inserted for convenience of reference only and do not affect the interpretation of any provision of this Agreement.
- 9.7. The failure of either party to exercise any right, power or option given hereunder or to insist upon the strict compliance with the terms and conditions hereof by the other party shall not constitute a waiver: (a) of the terms and conditions of this Agreement with respect to that or any other or subsequent breach thereof; or (b) by such party of its rights at any time thereafter to require compliance with all terms and conditions hereof including the terms or conditions with respect to which the other party has failed to exercise such right, power or option.
- 9.8. If any provision of this Agreement is declared invalid, illegal, or unenforceable by a court of competent jurisdiction such provision shall be deemed severed from the Agreement and all other provisions of the Agreement shall remain in full force and effect.
- 9.9. This Agreement may be executed by the parties in separate counterparts, each of which will be deemed to constitute an original, but all of which together will constitute one and the same Agreement. This Agreement will be considered to be fully executed when all parties have executed an identical counterpart, notwithstanding that all signatures may not appear on the same counterpart. This Agreement and those contemplated herein may be executed and delivered by facsimile signatures and will be binding on all parties hereto as if executed by original signature and delivered personally.
- 9.10. This Agreement shall inure to the benefit of and be binding upon the ABAA and the Manufacturer Licensee and their respective successors and permitted assigns, if any. This Agreement contains the entire Agreement between the parties in respect of its subject matter and supersedes all earlier agreements, understandings, negotiations and discussions, whether verbal or written. There are no conditions, covenants, agreements, representations, warranties or other provisions, express or implied, collateral, statutory or otherwise, relating to the subject matter hereof except as herein provided.

THE PARTIES HAVE DULY EXECUTED THIS AGREEMENT on the date first written above.

AIR BARRIER ASSOCIATION OF AMERICA, INC.

“Manufacturer Licensee”

Per: _____

Per: _____

Name: _____

Name: _____

Title: _____

Title: _____

Date: _____

Date: _____

Manufacturer Licensee initials: _____

Air Barrier Association of America, Inc. initials: _____

SCHEDULE "A"



Manufacturer Licensee initials: _____

Air Barrier Association of America, Inc. initials: _____