

List of Details

Mass Wall Details

- MW1 Mass Wall - Without Roof Deck Air Barrier
- MW2 Precast Concrete Panel - Without Roof Deck Air Barrier - Option A
- MW3 Precast Concrete Panel - Without Roof Deck Air Barrier - Option B
- MW4 Mass Wall - With Roof Deck Air Barrier - Option A
- MW5 Mass Wall - With Roof Deck Air Barrier - Option B
- MW6 Mass Wall - Gutter Edge With Roof Deck Air Barrier
- MW7 Mass Wall - Parapet With Roof Deck Air Barrier

Rainscreen Wall Details

- RS1 Rainscreen Wall - Roof Edge Without Roof Deck Air Barrier
- RS2 Rainscreen Wall - Roof Edge With Roof Deck Air Barrier
- RS3 Rainscreen Wall - Parapet With Foam Insulation Base Plug at Deck
- RS4 Rainscreen Wall - Parapet With Continuous Rigid Board Exterior Insulation
- RS5 Rainscreen Wall - Parapet With Insulation within Coping Blocking Assembly
- RS6 Rainscreen Wall - Roof Deck Air Barrier Prior to Parapet Extension Without Thermal Break
- RS7 Rainscreen Wall - Deck Air Barrier Prior to Parapet Extension With Thermal Break

Insulated Rainscreen Wall Details

- IRS1 Insulated Sheathing Rainscreen Wall - Roof Edge Without Roof Deck Air Barrier
- IRS2 Insulated Sheathing Rainscreen Wall - Roof With Roof Deck Air Barrier
- IRS3 Insulated Sheathing Rainscreen Wall - Parapet With Foam Insulation Base Plug at Deck

- IRS4 Insulated Sheathing Rainscreen Wall - Parapet With Continuous Rigid Board Exterior Insulation
- IRS5 Insulated Sheathing Rainscreen Wall - Parapet With Foam Insulation at Top of Parapet
- IRS6 Insulated Sheathing Rainscreen Wall - Parapet With Insulation within Coping Blocking Assembly
- IRS7 Insulated Sheathing Rainscreen Wall - AVR Installation Prior to Parapet Extension - Without Thermal Break
- IRS8 Insulated Sheathing Rainscreen Wall - AVR Installation Prior to Parapet Extension - With Thermal Break

Roof-to-Wall Transition Details

- RW1 Roof-to-Rising-Wall-Transition - Brick Shelf With Stand off Clips
- RW2 Roof-to-Rising-Wall Transition - Structural Thermal Break

Roof Overhang Details

- CL1 Roof Overhang - With Air Barrier Transition Through Metal Deck
- CL3 Roof Overhang - With Structural Thermal Break
- CL5 Roof Overhang - With Air Barrier Wrapping Overhang

Typical Detail Conditions

- IM1 Solutions for Incompatible Roof and Wall Membranes

General Notes

Using These Details

- The intent of these details is to show air barrier continuity at common interfaces. Thermal and water vapor control strategies shown may not be suitable for all building types and/or climate zones.
- Details in this guide may be applicable to retrofitting existing buildings, but this guide is intended for new construction.
- Cavity insulation is not depicted in these details unless acting as a component of the air barrier.
- Many wall and roof membrane materials may or may not also function as vapor retarders, which are not addressed by these details. It is up to the designer to consider what level of vapor permeance is appropriate for their project in their climate.
- Structural components depicted in these details are representational in nature. Details must be reviewed and approved by a structural engineer for compliance with project requirements.
- Where differential movement between structural components is anticipated, detail roofing and air barrier materials to accommodate expected movement.
- Annotation items in **bold font** denote air barrier components for that detail condition.
- Detail linework and graphics depicted in shades blue denote air barrier components for that detail condition. Annotations depicted in **bold** similarly denote air barrier components.
- Minimum membrane overlaps are 2" in length, unless otherwise noted or as required by the manufacturer.
- For information regarding the sheet metal drip edge, cleat, and related fasteners, refer to the ANSI/SPRI/FM 4435/ES-1 and NRCA ES-1 program. For FM insured projects, refer to FM 1-49.

Mass Wall as an Air Barrier

- Where mass walls are depicted, bare precast concrete or cast-in-place concrete or multi-wythe mass masonry acts as the air barrier if joints and penetrations are sealed and it is tied into the whole building air barrier system. Composite brick/CMU walls and CMU block walls require the use of air barrier membranes or coatings.
- Multi-wythe brick and other existing mass masonry wall systems may function as an air barrier in the field of the wall, but transitioning a new roof onto an existing wall requires a

thorough understanding and evaluation of existing conditions.

High Temperature Resistant Membranes

- On dark color roofs, ensure that the air and vapor barrier membrane is suitable for high temperatures as it extends above the insulation to interface with the roof membrane.
- During extreme high temperatures, self-adhered membranes closer to sheet metal may have adhesives that soften and ooze, causing stains, and top sheets that shrink or melt. Designer is advised to use a high temperature self-adhered membrane where it is not insulated from exterior high temperatures.

Membrane Compatibility and Adhesion

- Membrane incompatibility often occurs at roof edge conditions. Refer to conceptual "Incompatible Membrane Solutions" shown in details IM1.
- There are well known compatibility issues between thermoplastic roof membranes and asphalt-based flashing membranes
- When adhering roof membrane to self adhering membrane flashing and sealant, ensure the chemical compatibility between both materials **and** conduct testing for quality of long-term adhesion during mockup stage.
- Many details depict the roof air and vapor barrier extending vertically to seal with the roof membrane. Verify this approach with roof membrane manufacturer to confirm this is a warrantable condition.
- Ensure that the roof membrane, especially thermoplastic and EPDM roofing, is compatible with the air and vapor barrier membrane or any other transitional flashing membranes. A separate transition membrane may be needed where the roof membrane and air/vapor barrier membrane interface above the level of the insulation.

Parapet Height

- Review all parapets for condensation risk and thermal losses for all parapet heights.
- Parapets wrapped with continuous insulation are still at risk for condensation in colder climate zones, especially in conditions where parapets are greater than 2' (612mm) in height.
- Where condensation risks occur, consider detailing that excludes the parapet from the air and thermal boundary. Refer to concepts shown in Details RS3, RS7, RS8, IRS7, and IRS8.

Industry References

These details are intended to focus on air barrier continuity, but by necessity show many other building components. These components are depicted generically in these details but are outside of the purview of the Air Barrier Association. Helpful resources regarding these other components can be found through the organizations listed below:

- NRCA: National Roofing Contractors Association
- SPRI: Single Ply Roofing Industry
- SMACNA: Sheet Metal and Air Conditioning Contractors' National Association
- RAINA: Rainscreen Association in North America
- BIA: Brick Industry Association
- TMS: The Masonry Society
- PCI: Precast / Prestressed Concrete Institute
- MCA: Metal Construction Association
- FGIA: Fenestration and Glazing Industry Alliance
- SSMA: Steel Stud Manufacturers Association

Detail MW1

Mass Wall - Without Roof Deck Air Barrier (2D)

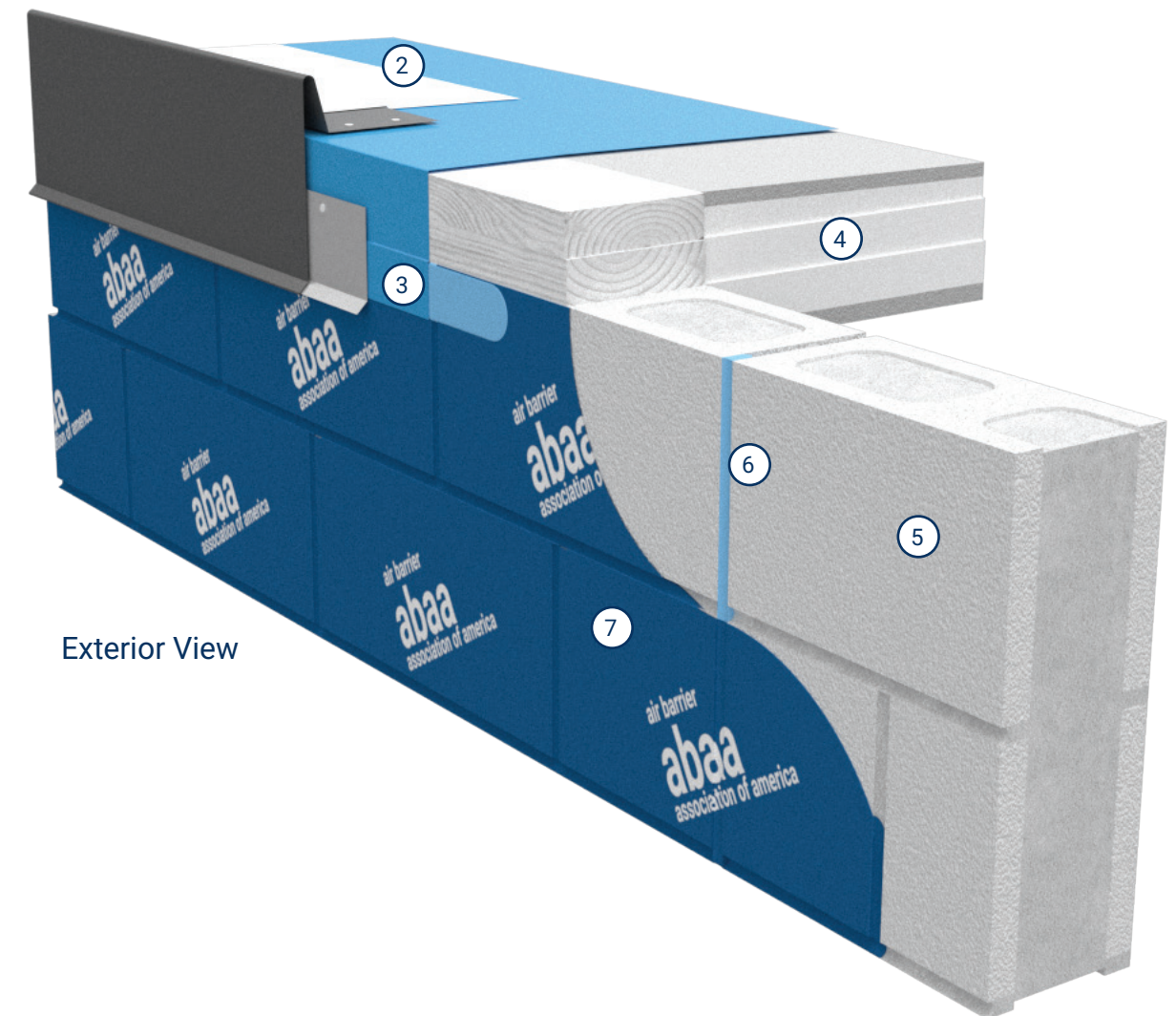
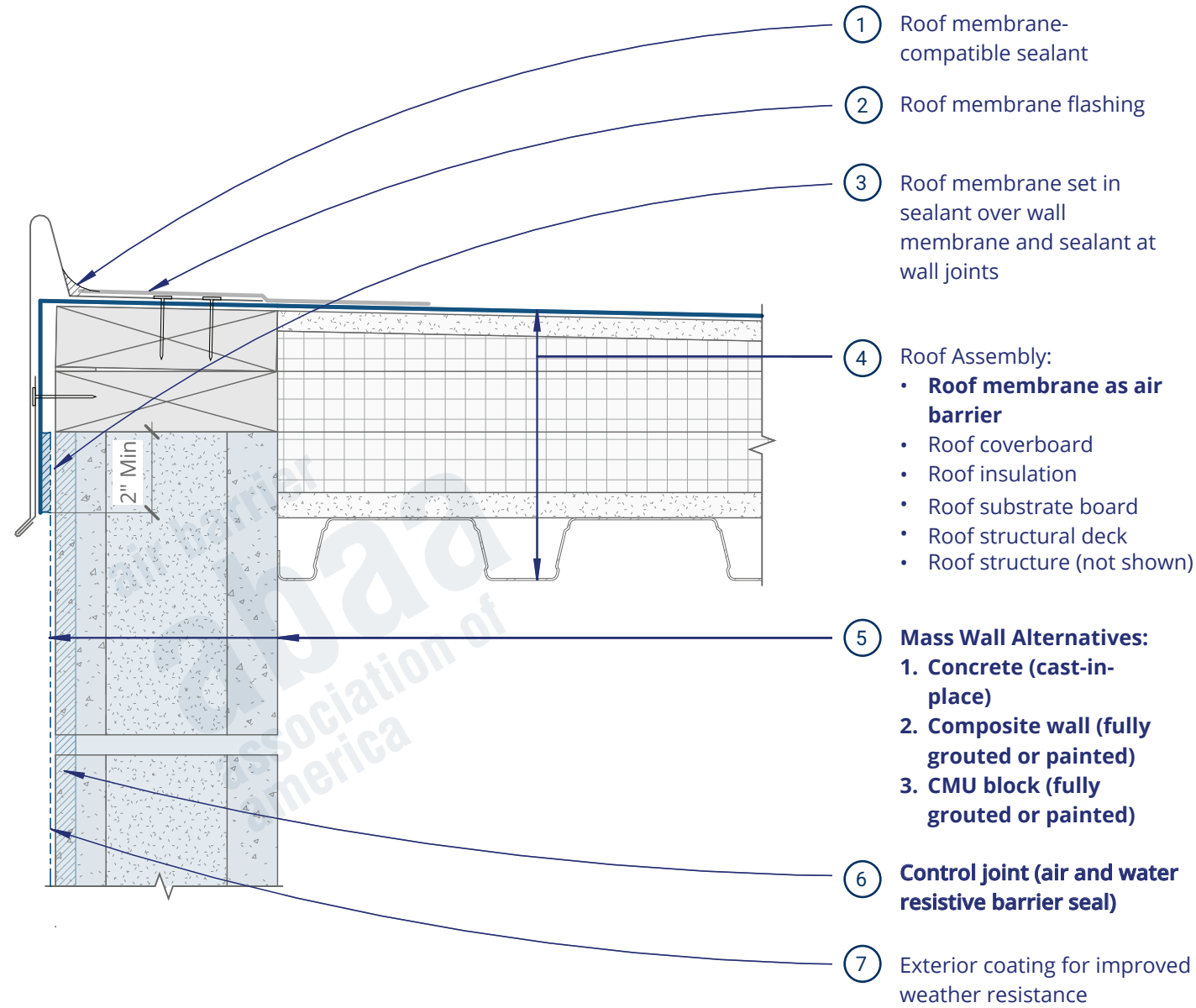

Mass Wall - Without Roof Deck Air Barrier (3D)

Detail MW2

Precast Concrete Panel - Without Roof Deck Air Barrier - Option A (2D)

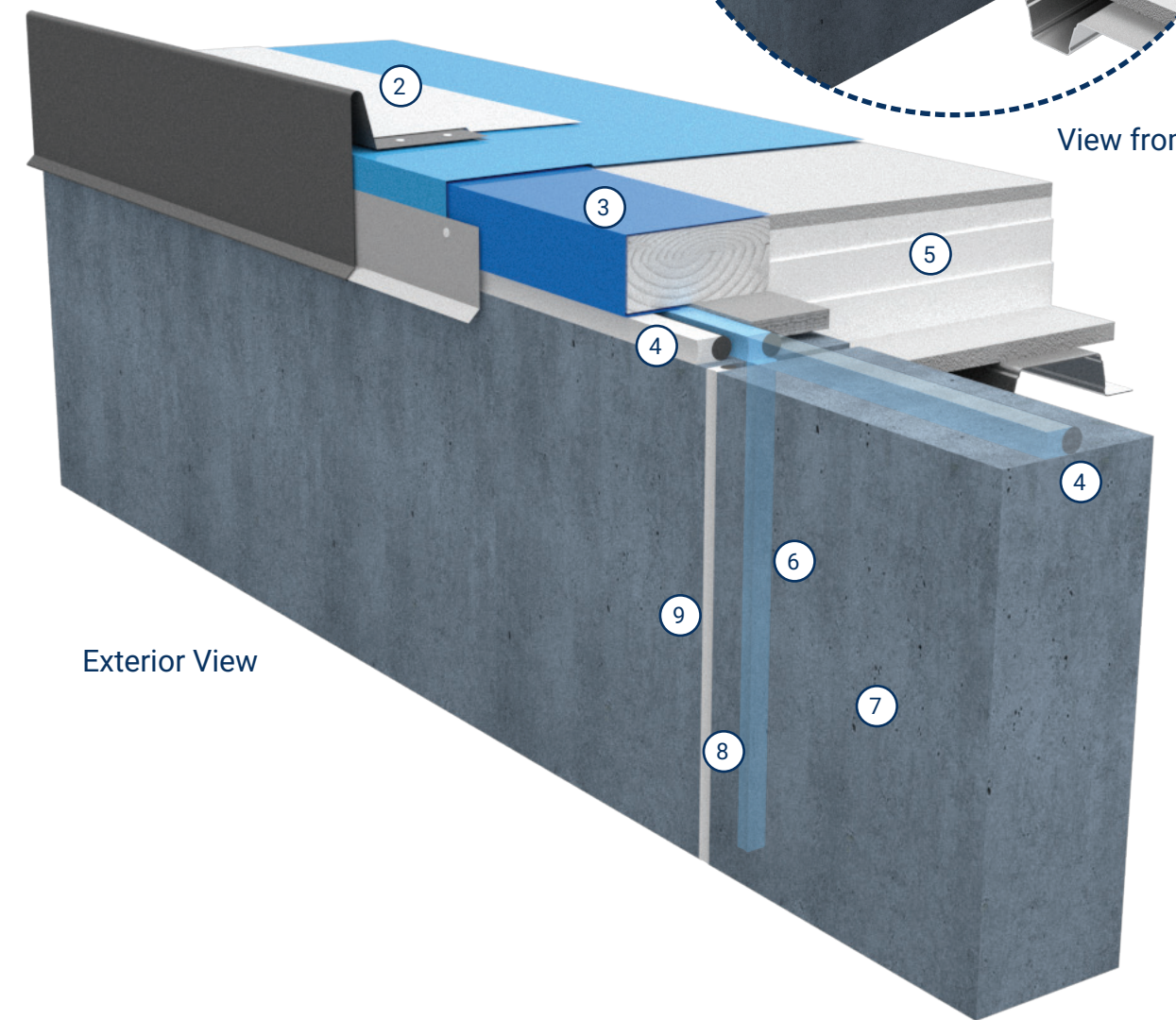
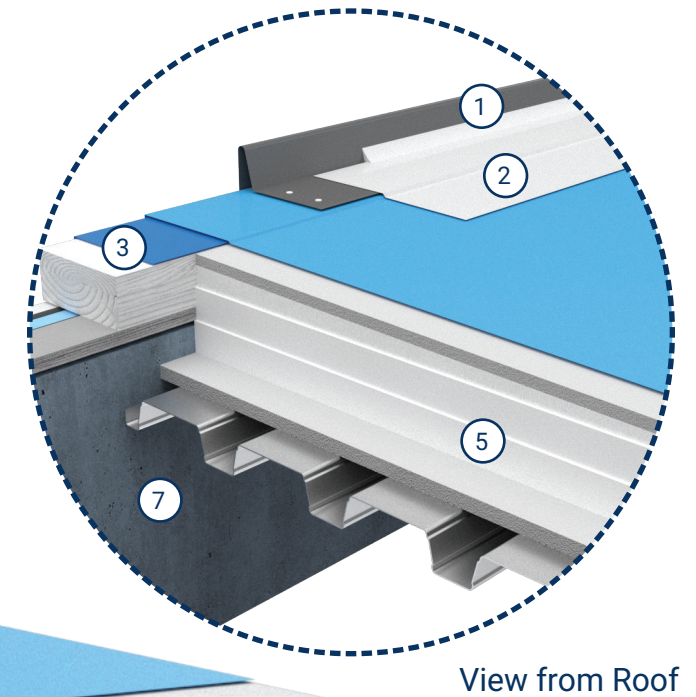
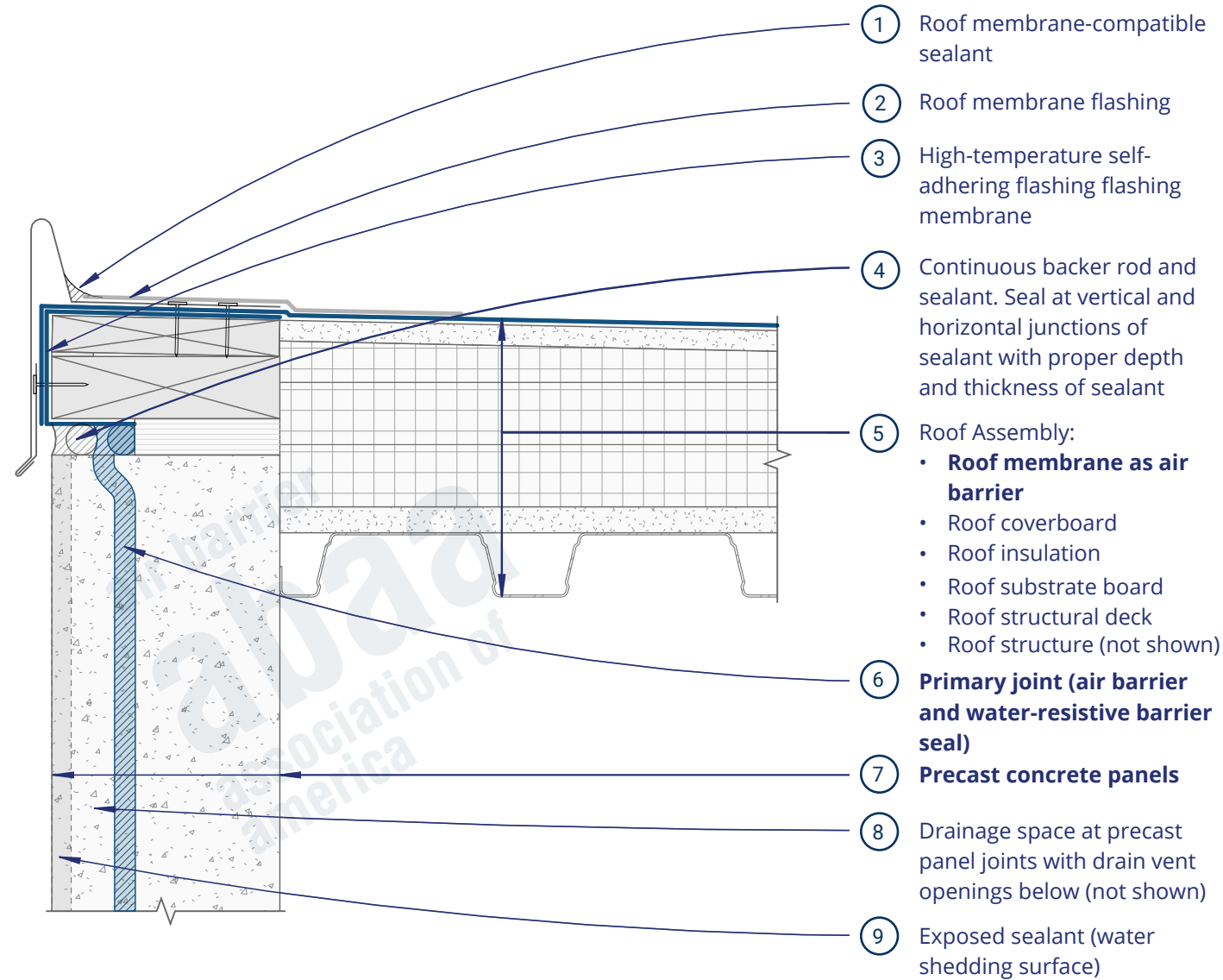

Precast Concrete Panel - Without Roof Deck Air Barrier - Option A (3D)

Detail MW3

Precast Concrete Panel - Without Roof Deck Air Barrier - Option B (2D)

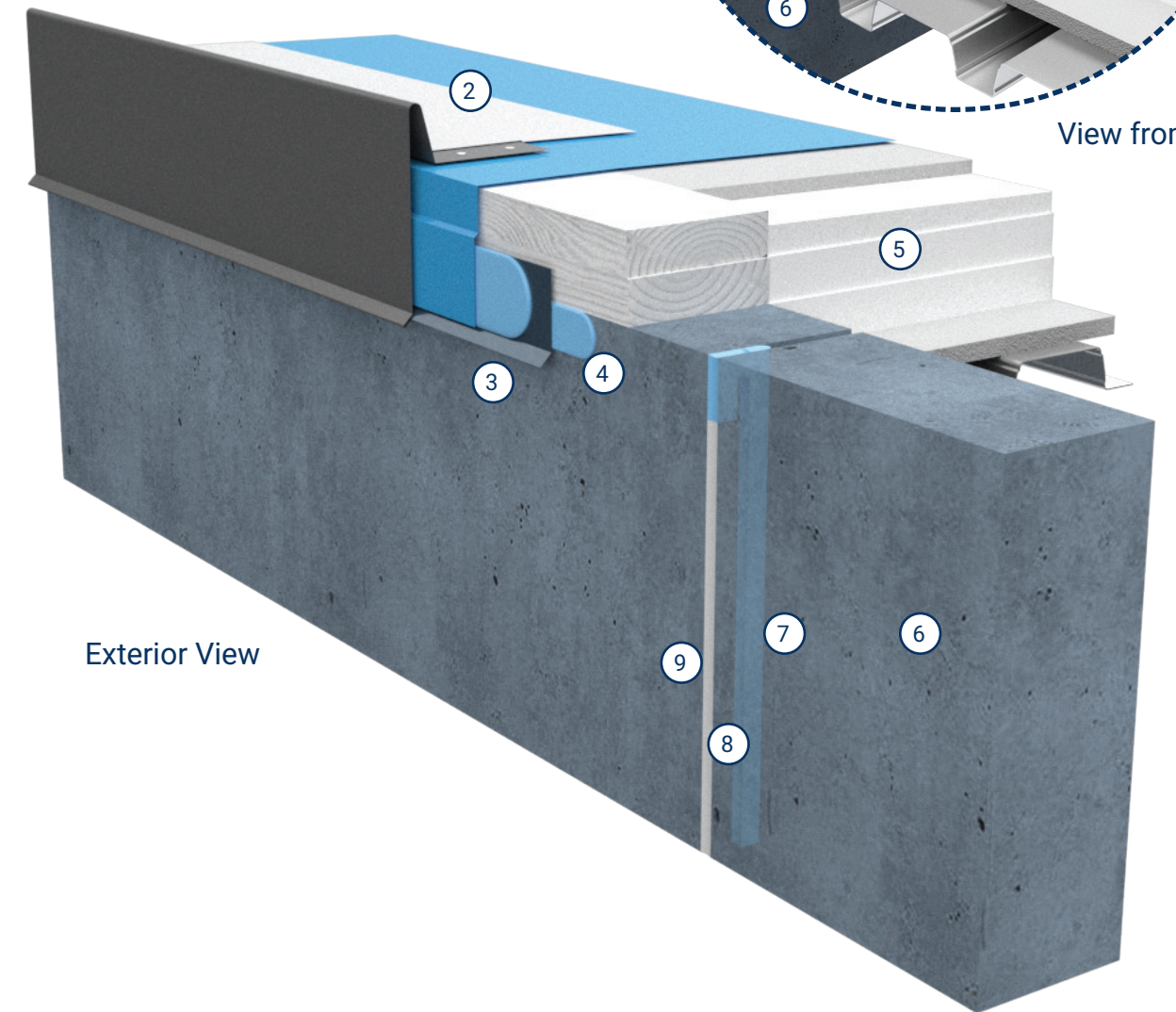
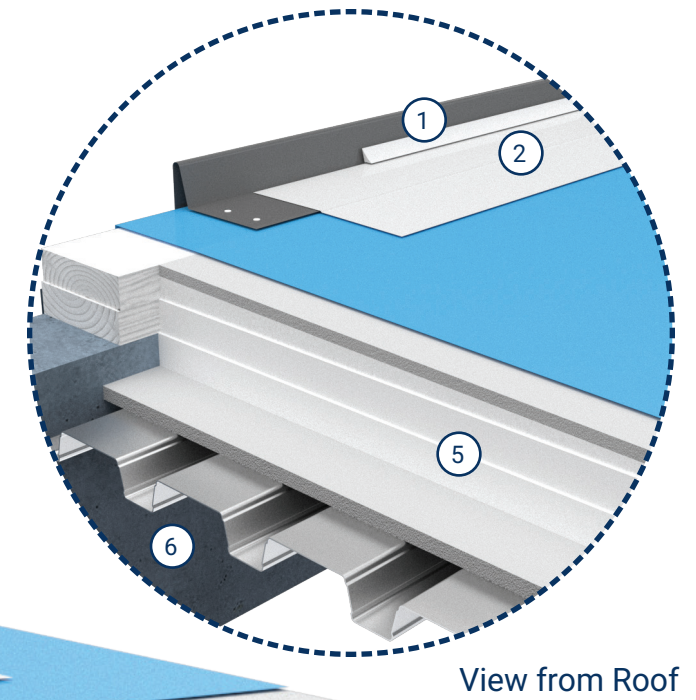
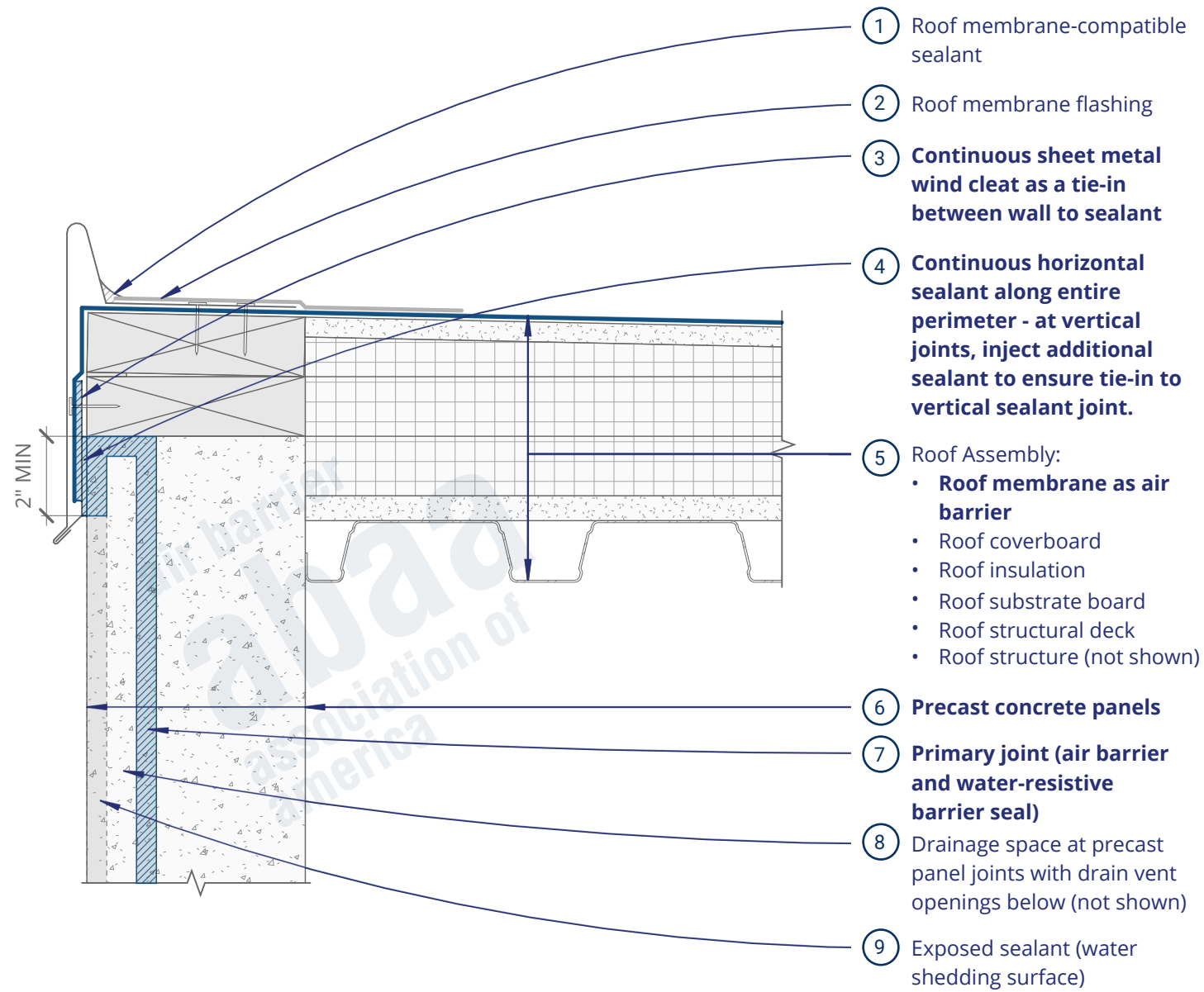

Precast Concrete Panel - Without Roof Deck Air Barrier - Option B (3D)

Detail MW4

Mass Wall - With Roof Deck Air Barrier - Option A (2D)

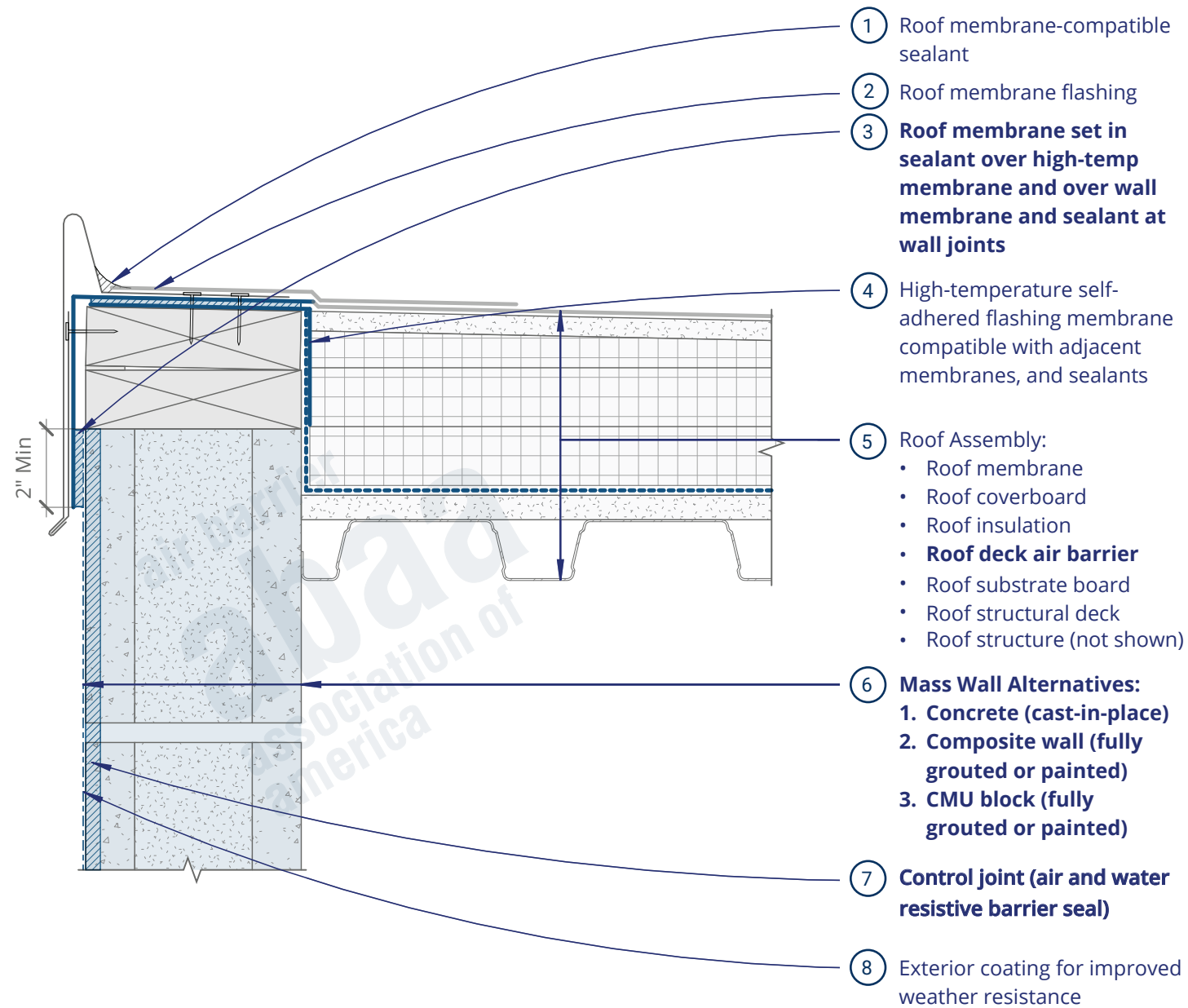

GUIDE DETAILS: ROOF-TO-WALL TRANSITIONS

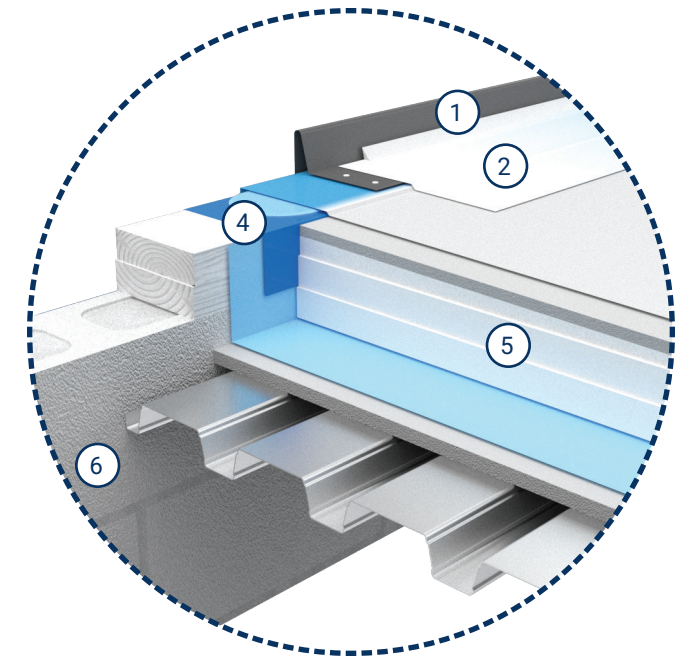

View from Roof

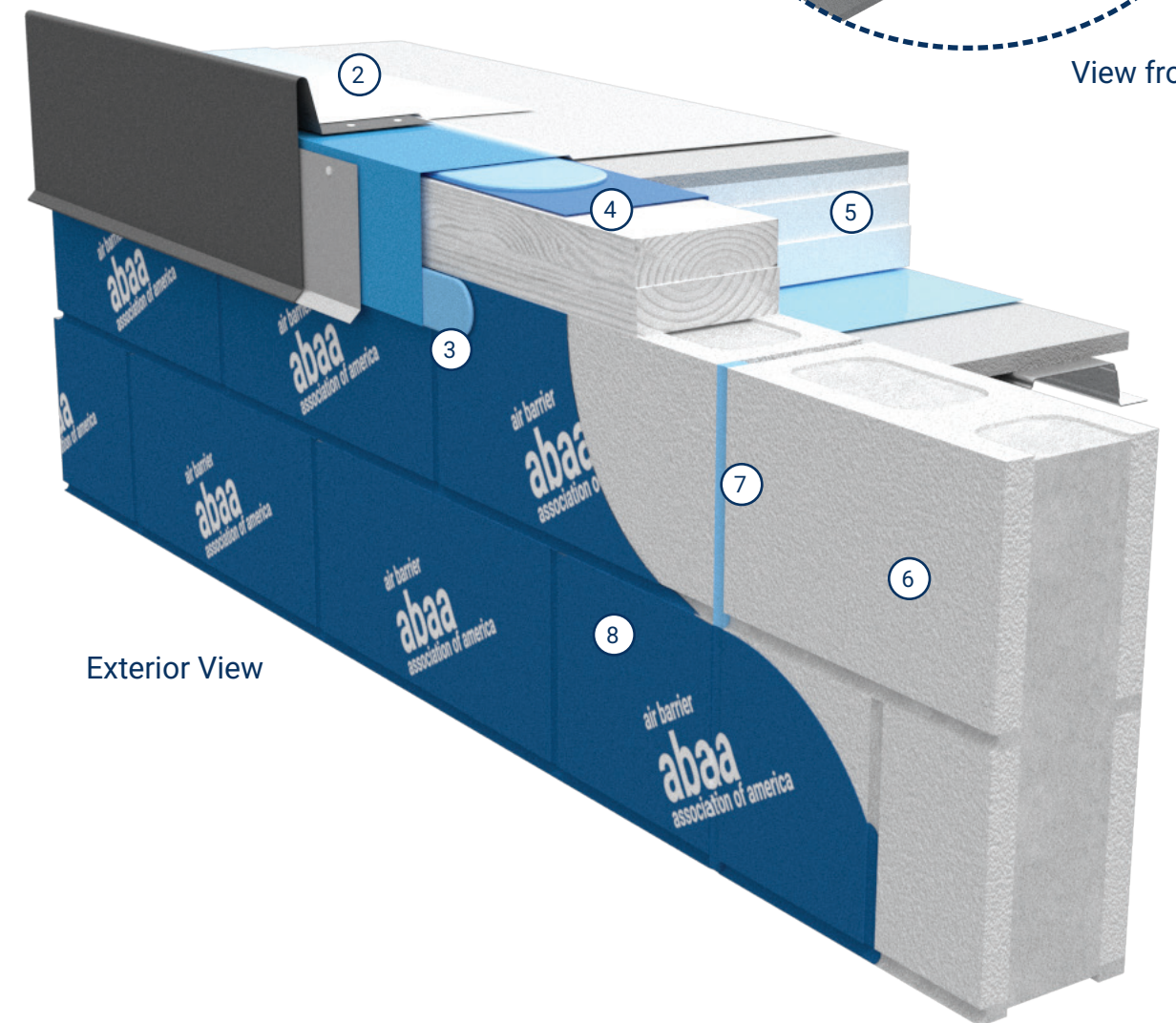

Exterior View

Mass Wall - With Roof Deck Air Barrier - Option A (3D)

Detail MW5

Mass Wall - With Roof Deck Air Barrier - Option B (2D)

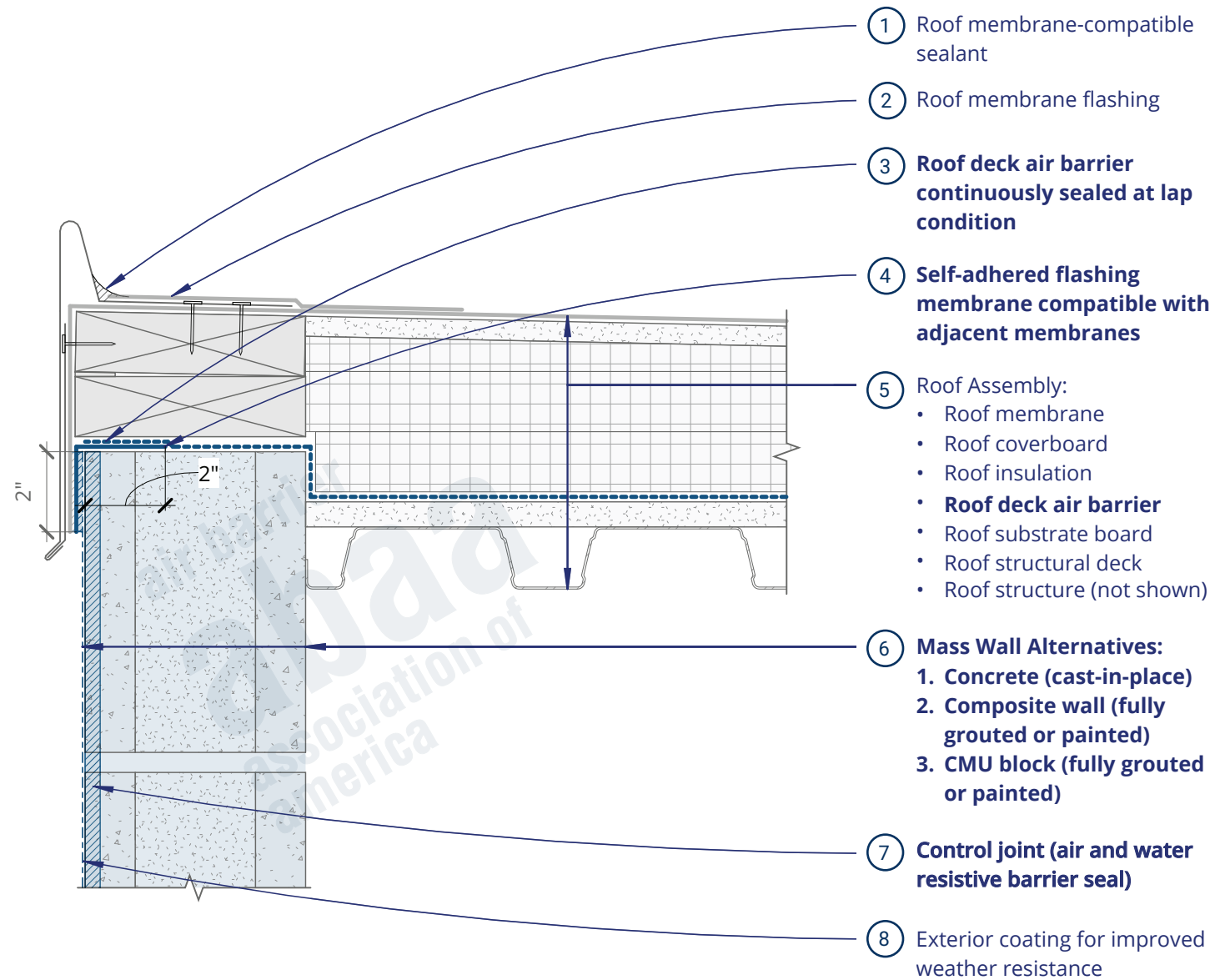

GUIDE DETAILS: ROOF-TO-WALL TRANSITIONS

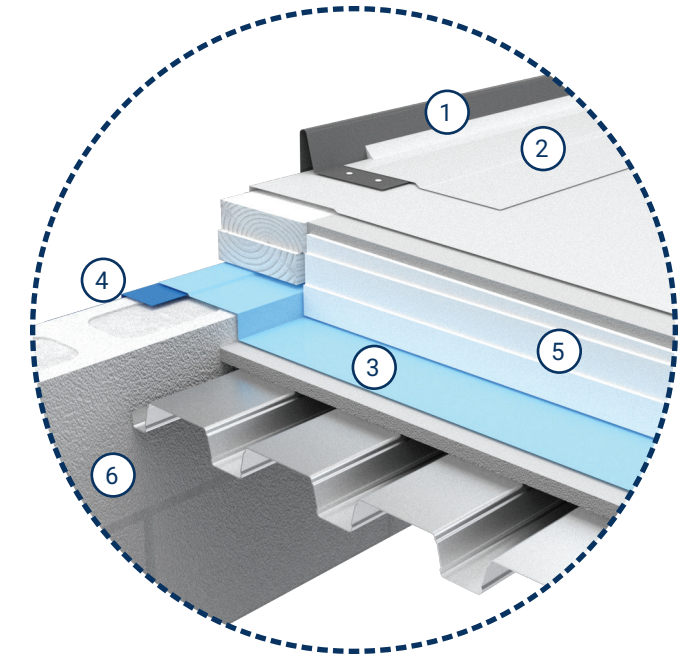

View from Roof

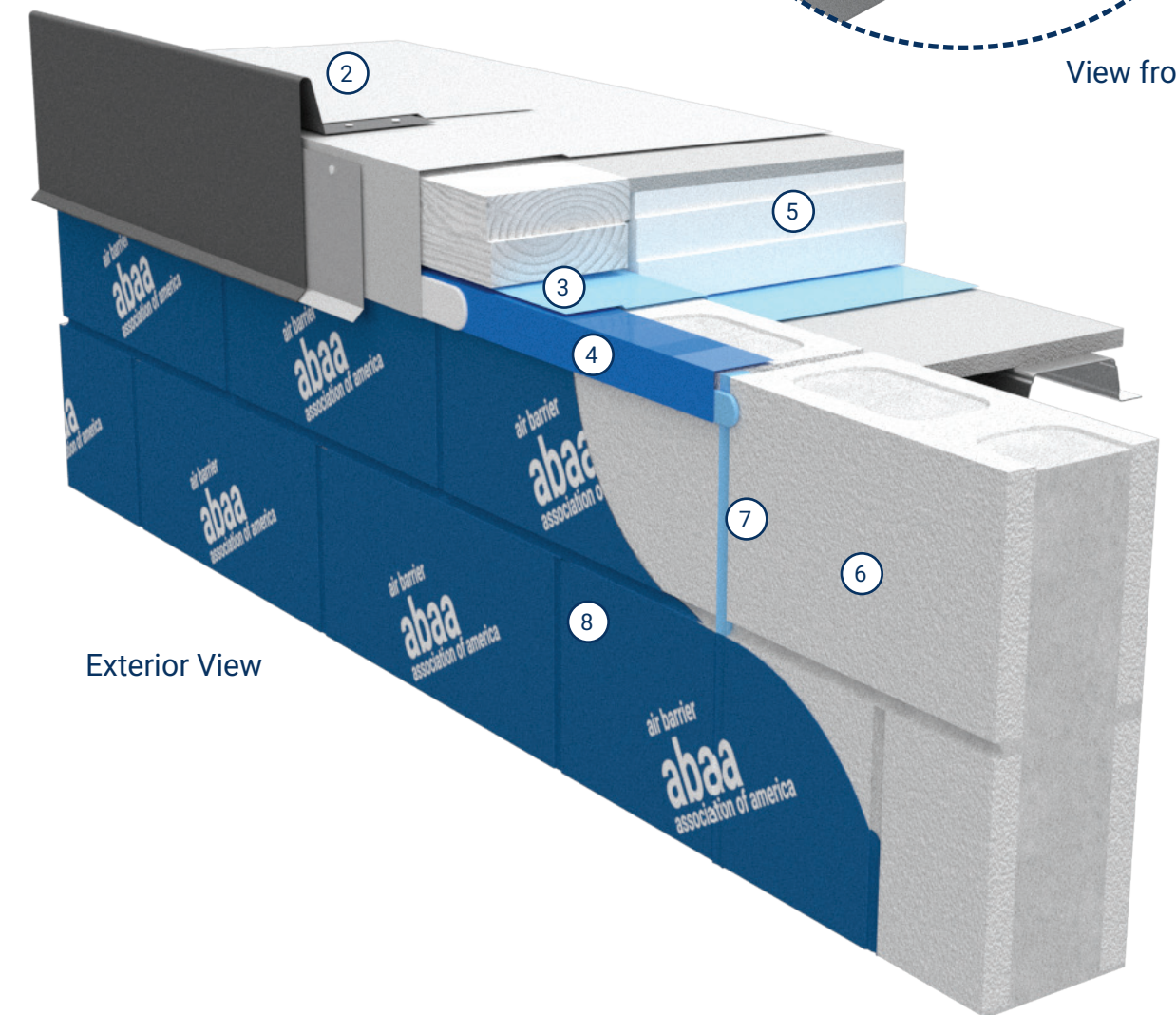

Exterior View

Mass Wall - With Roof Deck Air Barrier - Option B (3D)

Detail MW6

Mass Wall - Gutter Edge With Roof Deck Air Barrier (2D)

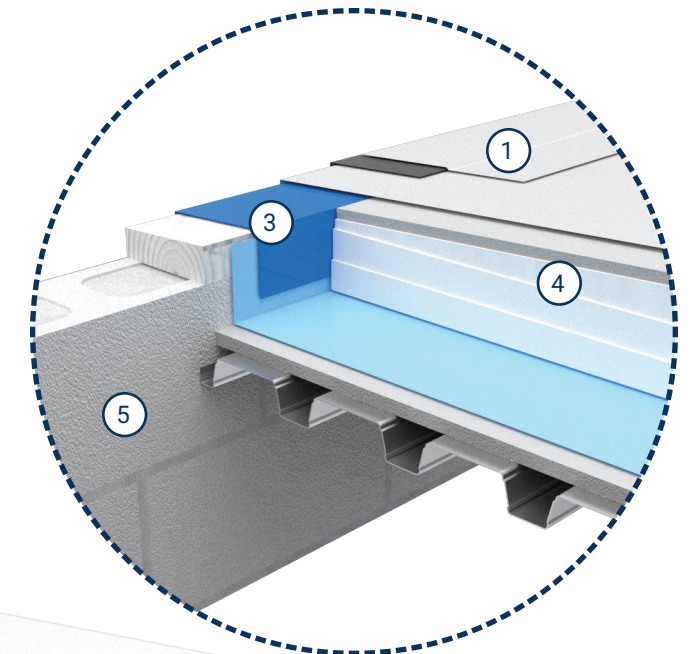
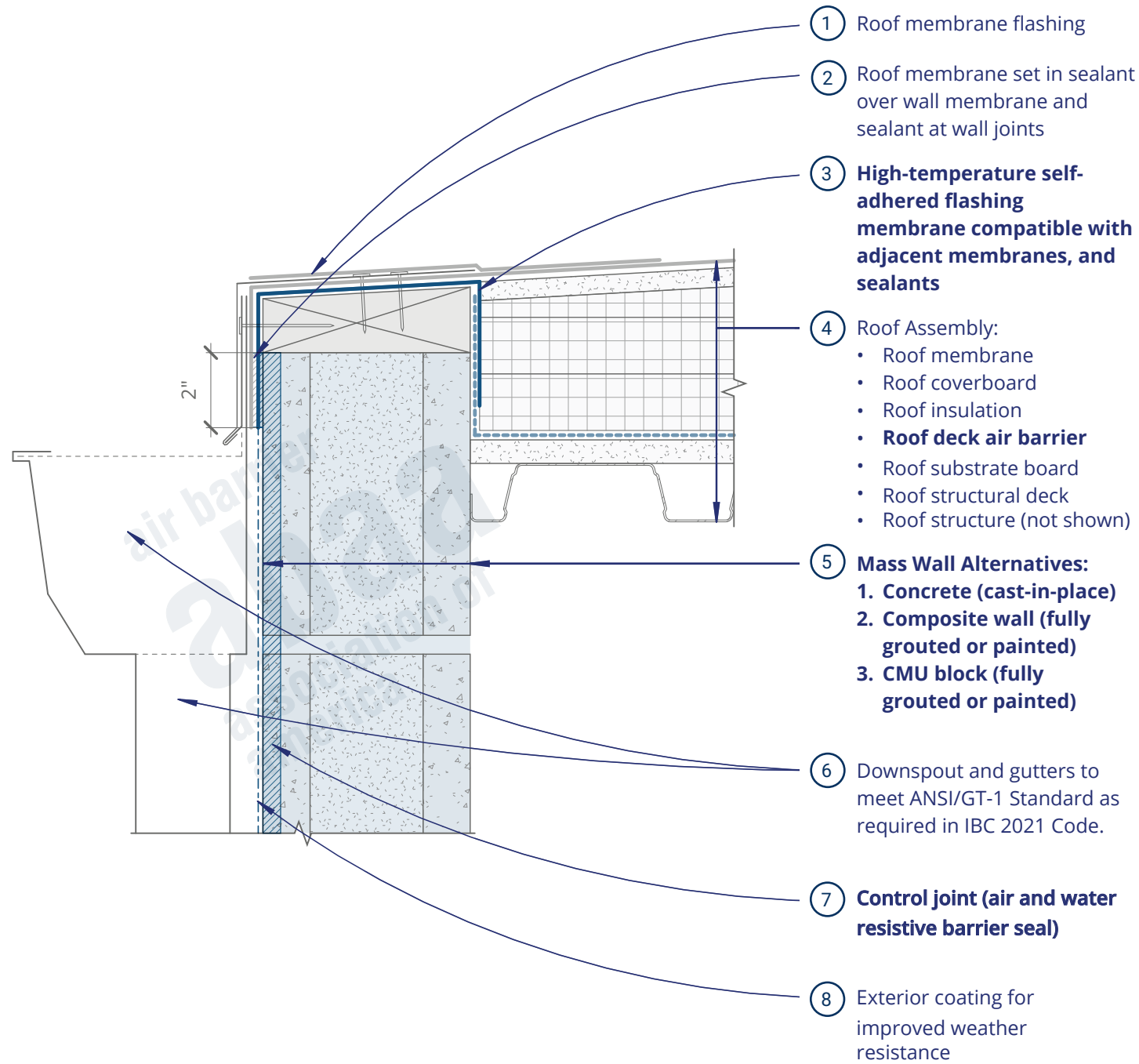

View from Roof

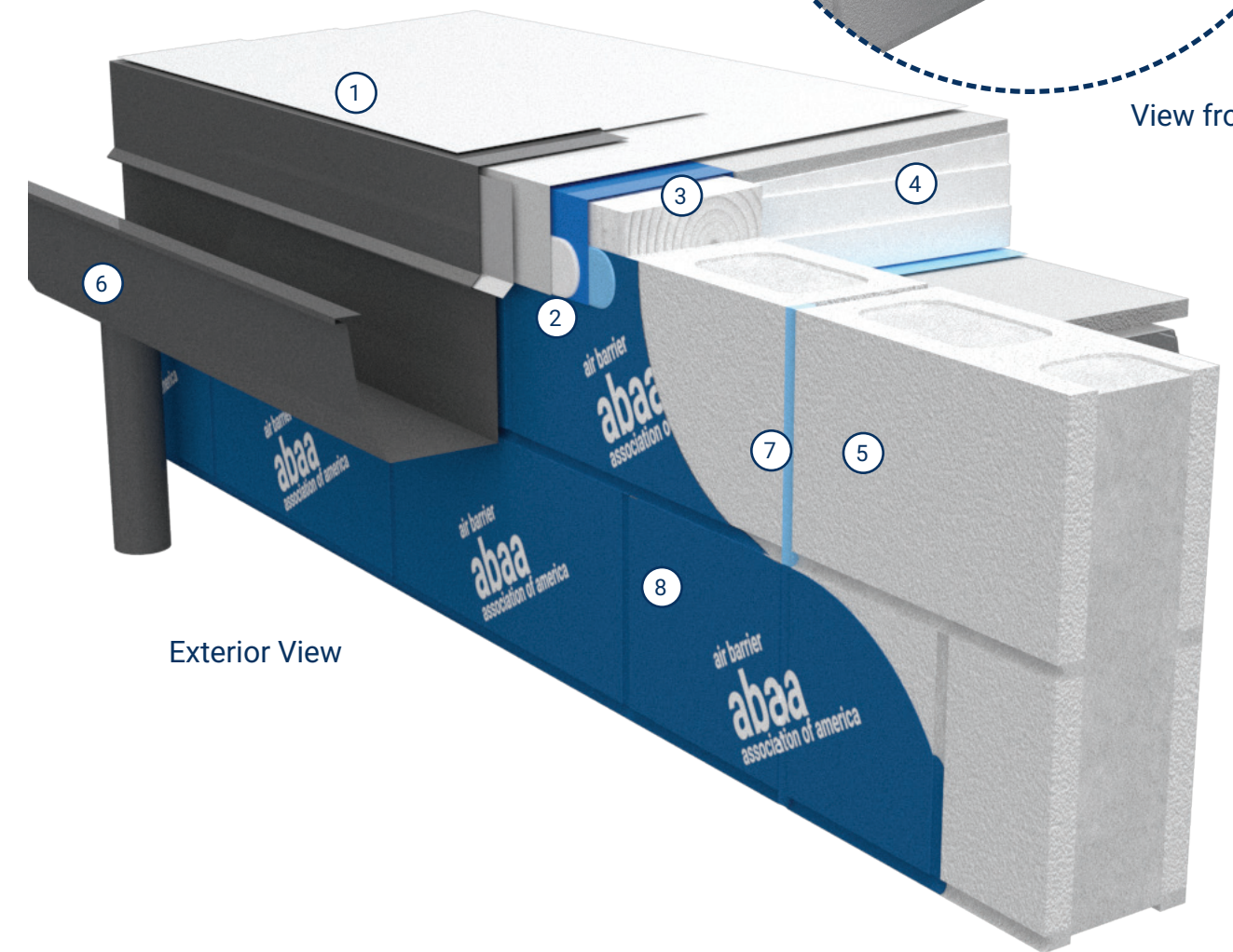

Exterior View

Mass Wall - Gutter Edge With Roof Deck Air Barrier (3D)

Detail MW7

Mass Wall - Parapet With Roof Deck Air Barrier (2D)

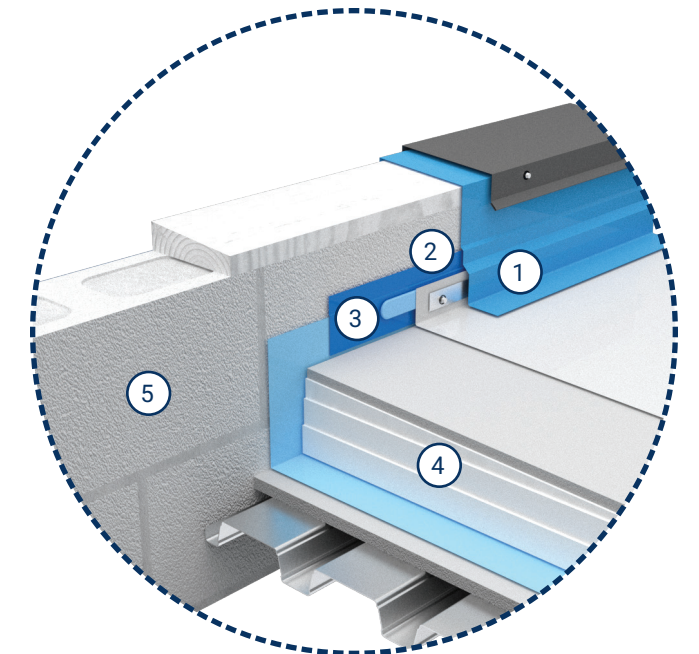
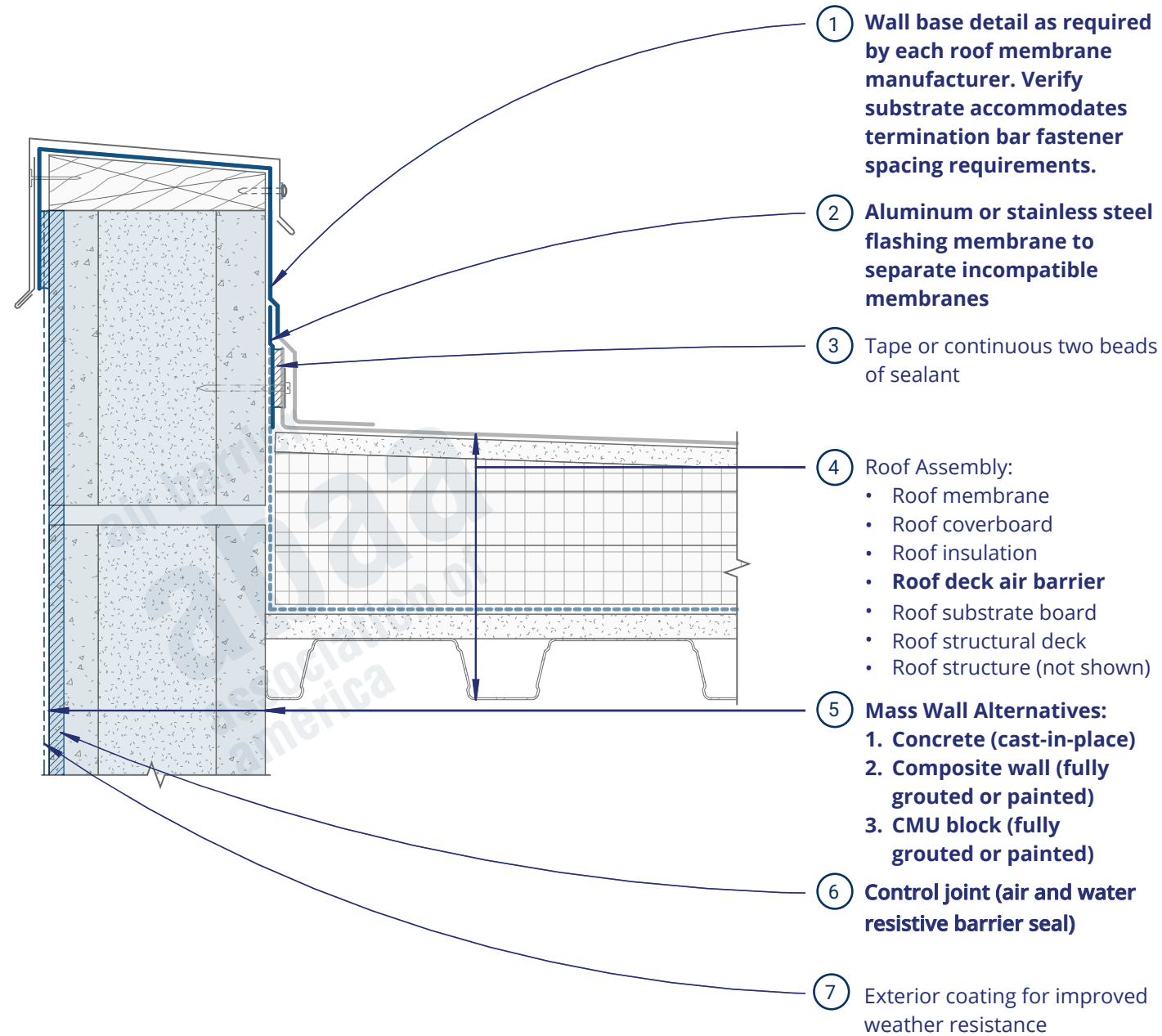

View from Roof

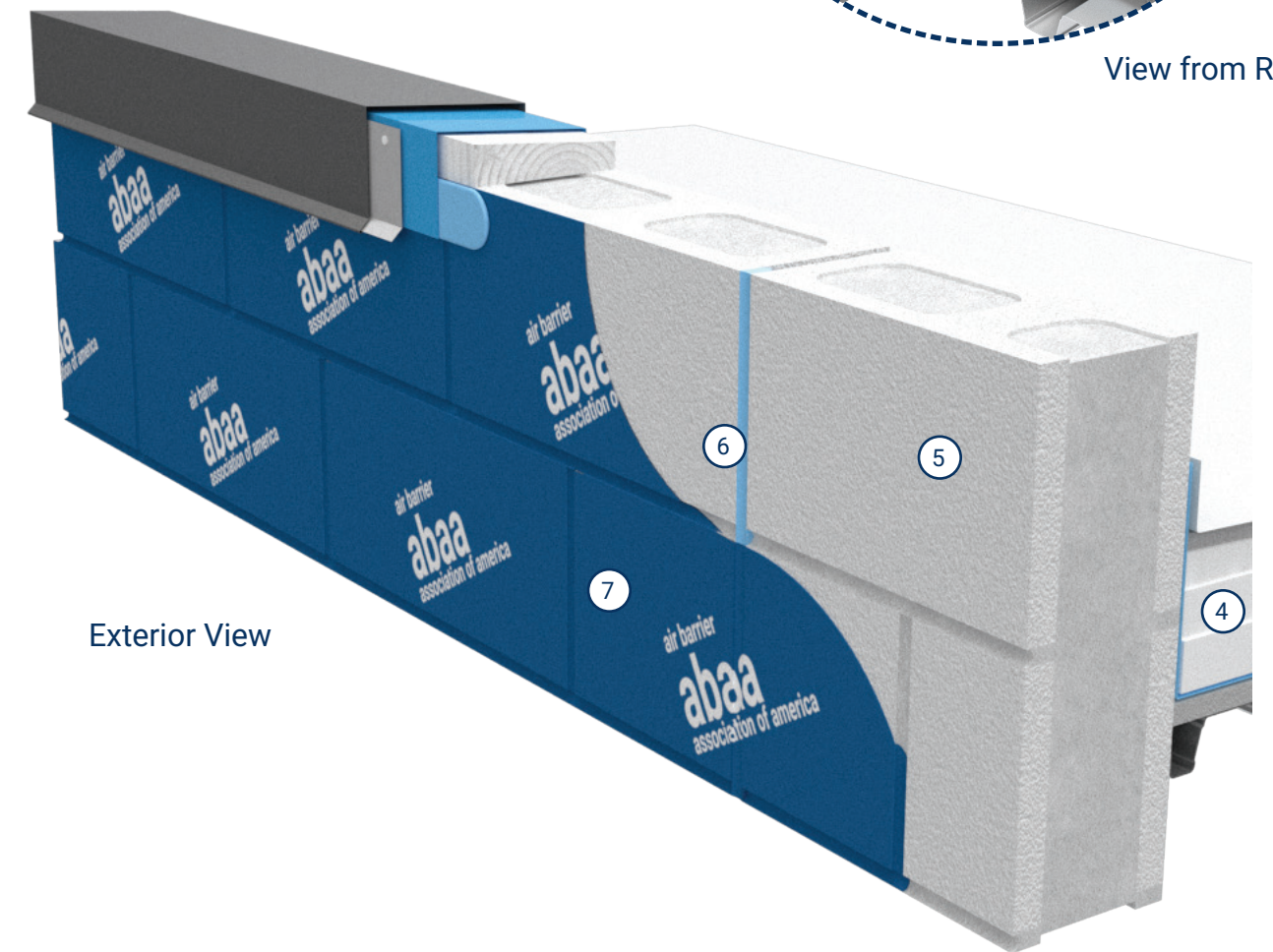

Exterior View

Mass Wall - Parapet With Roof Deck Air Barrier (3D)

Detail RS1

Rainscreen Wall - Roof Edge Without Roof Deck Air Barrier (2D)

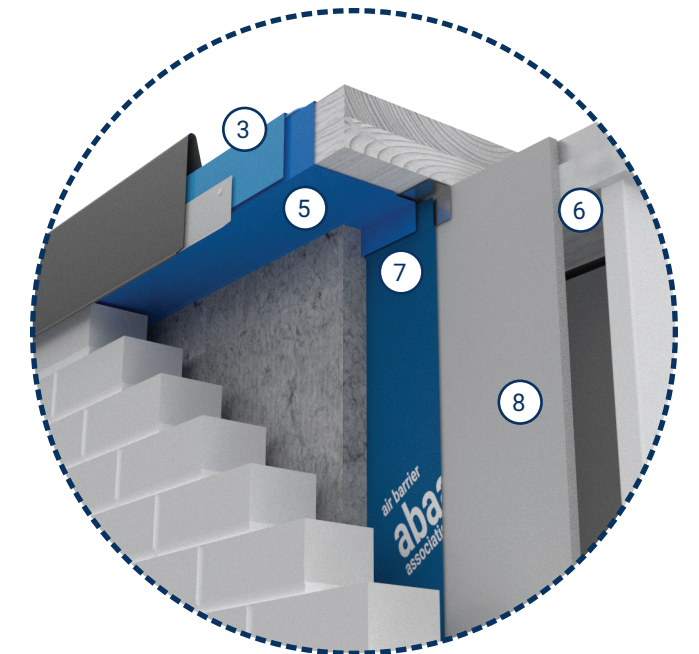
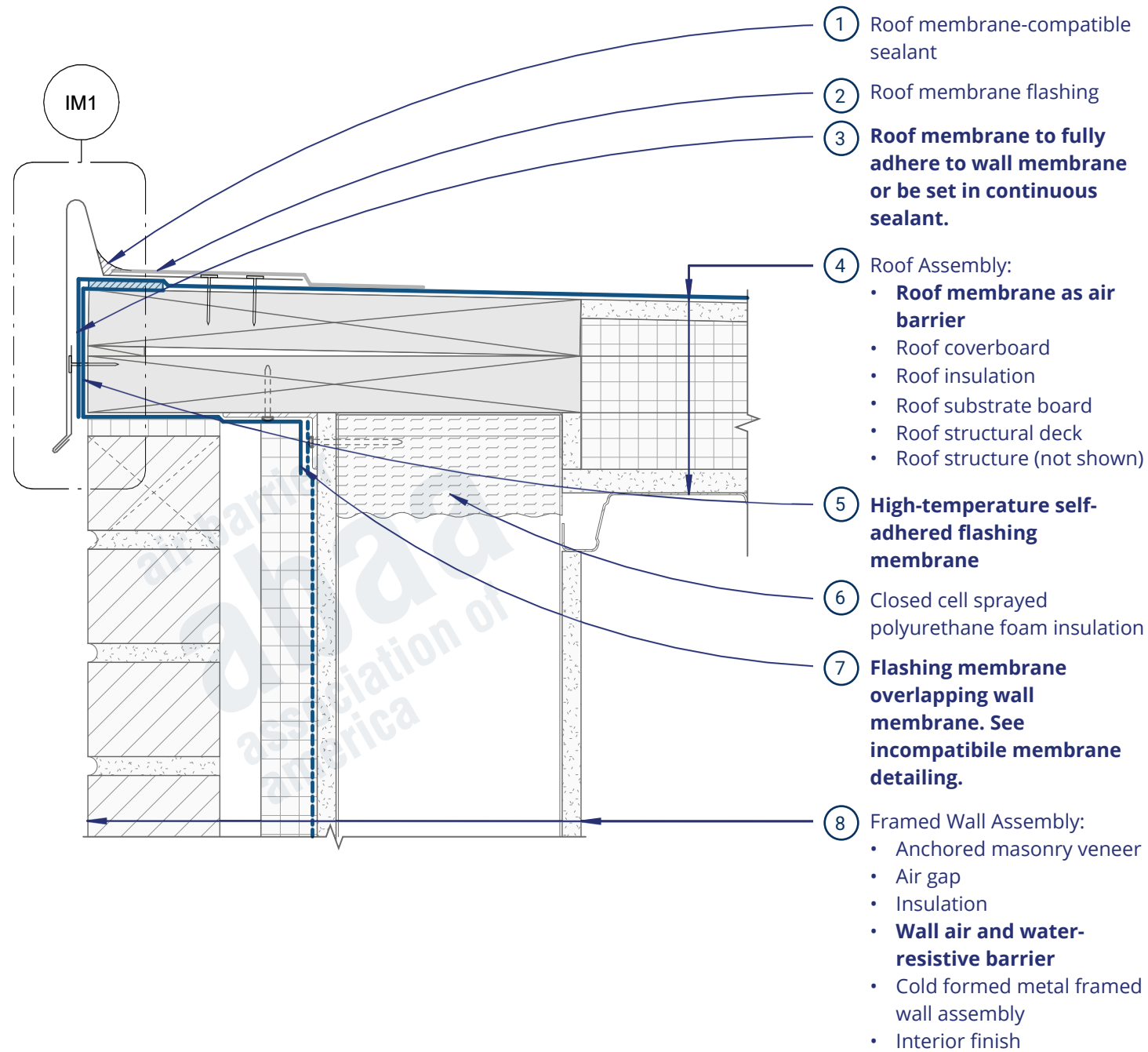

View from Underside

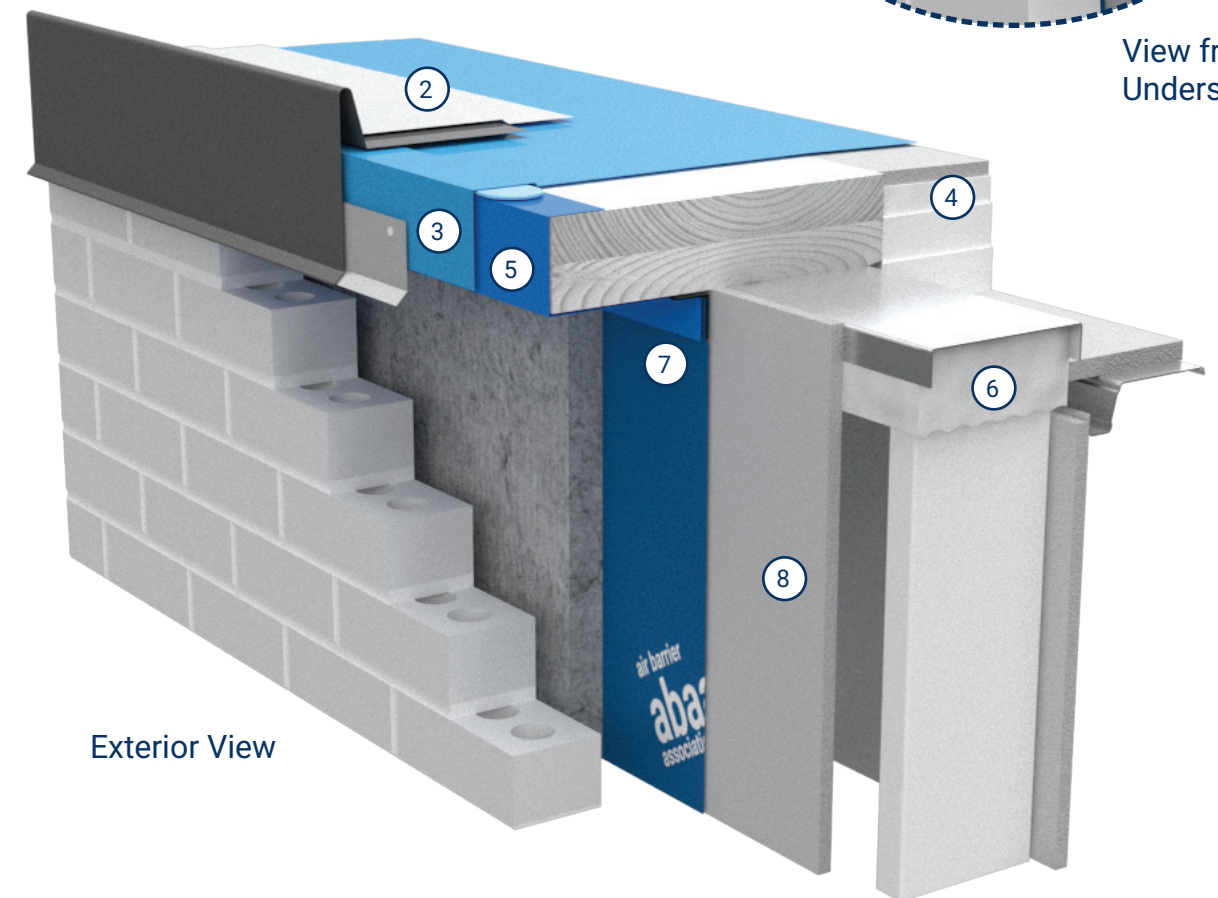

Exterior View

Rainscreen Wall - Roof Edge Without Roof Deck Air Barrier (3D)

Detail RS2

Rainscreen Wall - Roof Edge With Roof Deck Air Barrier (2D)

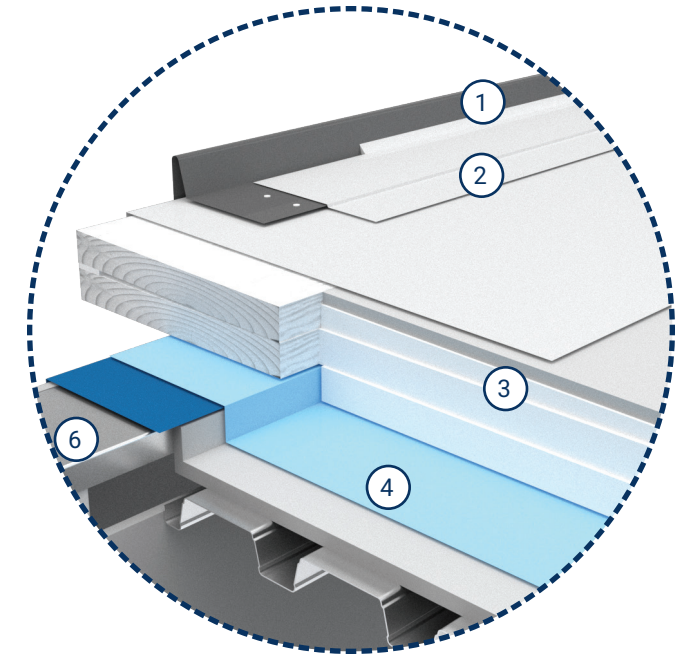
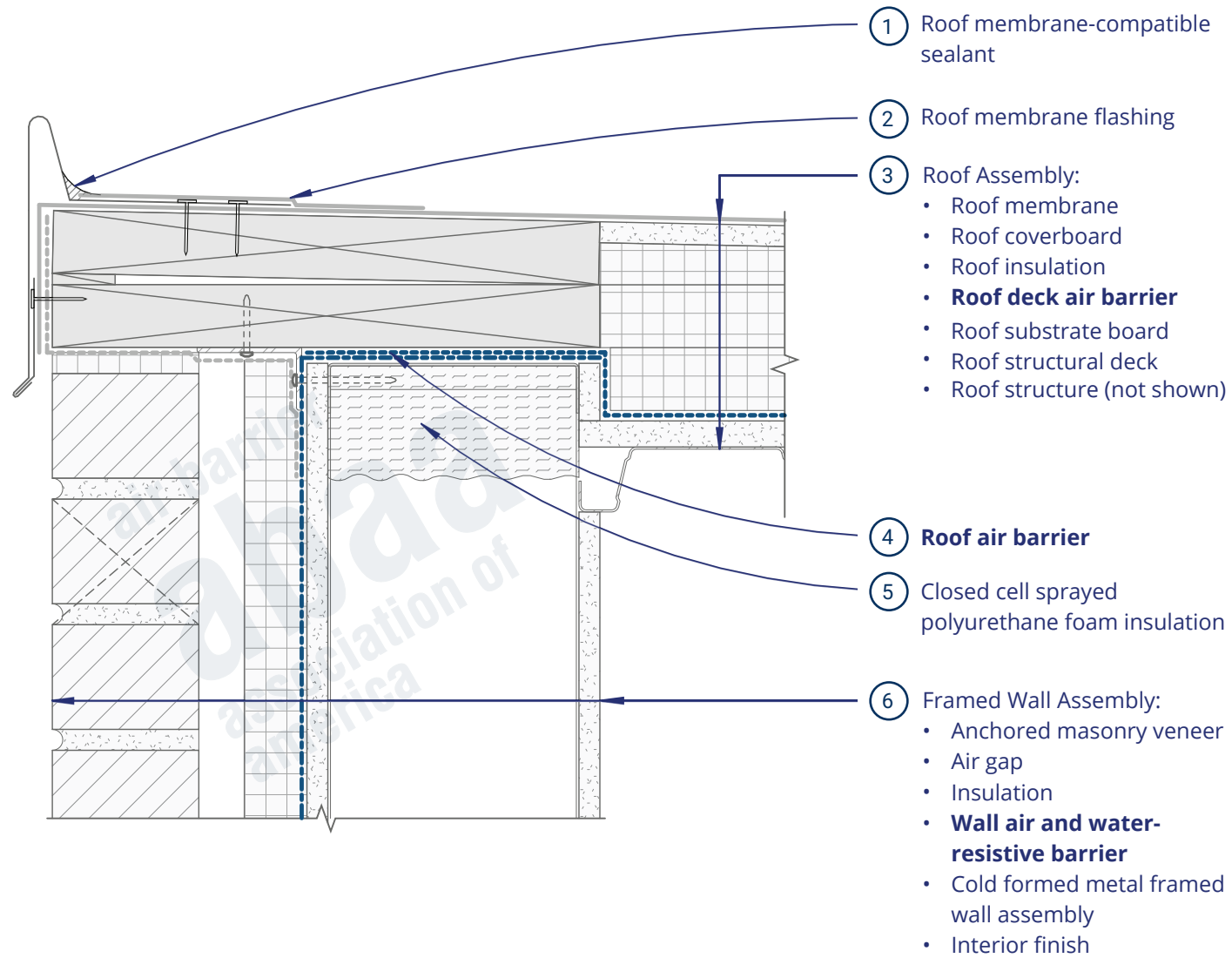

View from Roof

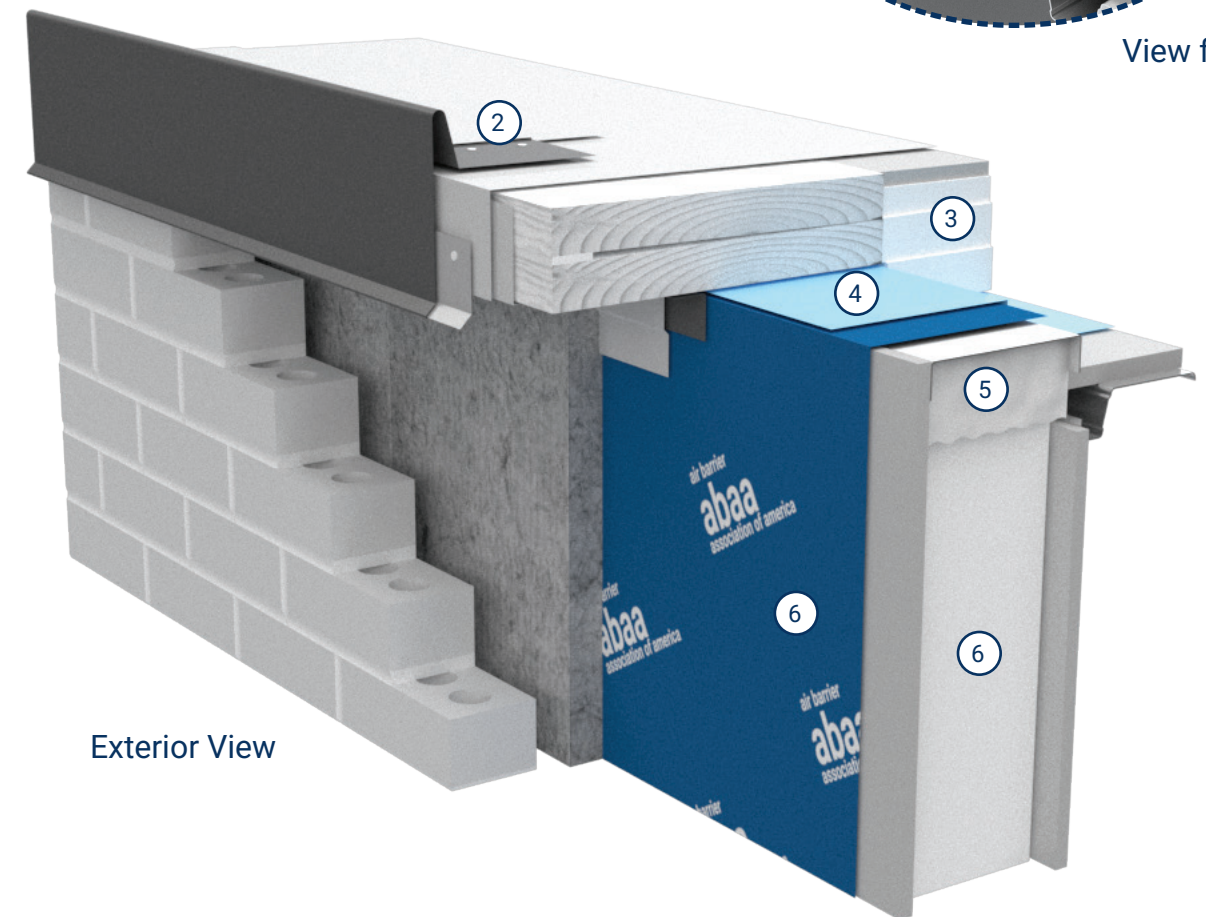

Exterior View

Rainscreen Wall - Roof Edge With Roof Deck Air Barrier (3D)

Detail RS3

Rainscreen Wall - Parapet With Foam Insulation Base Plug at Deck (2D)

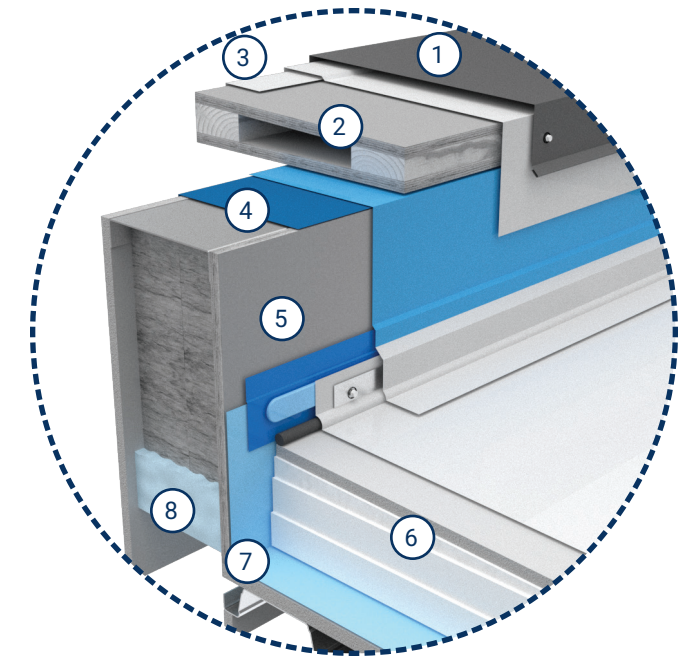
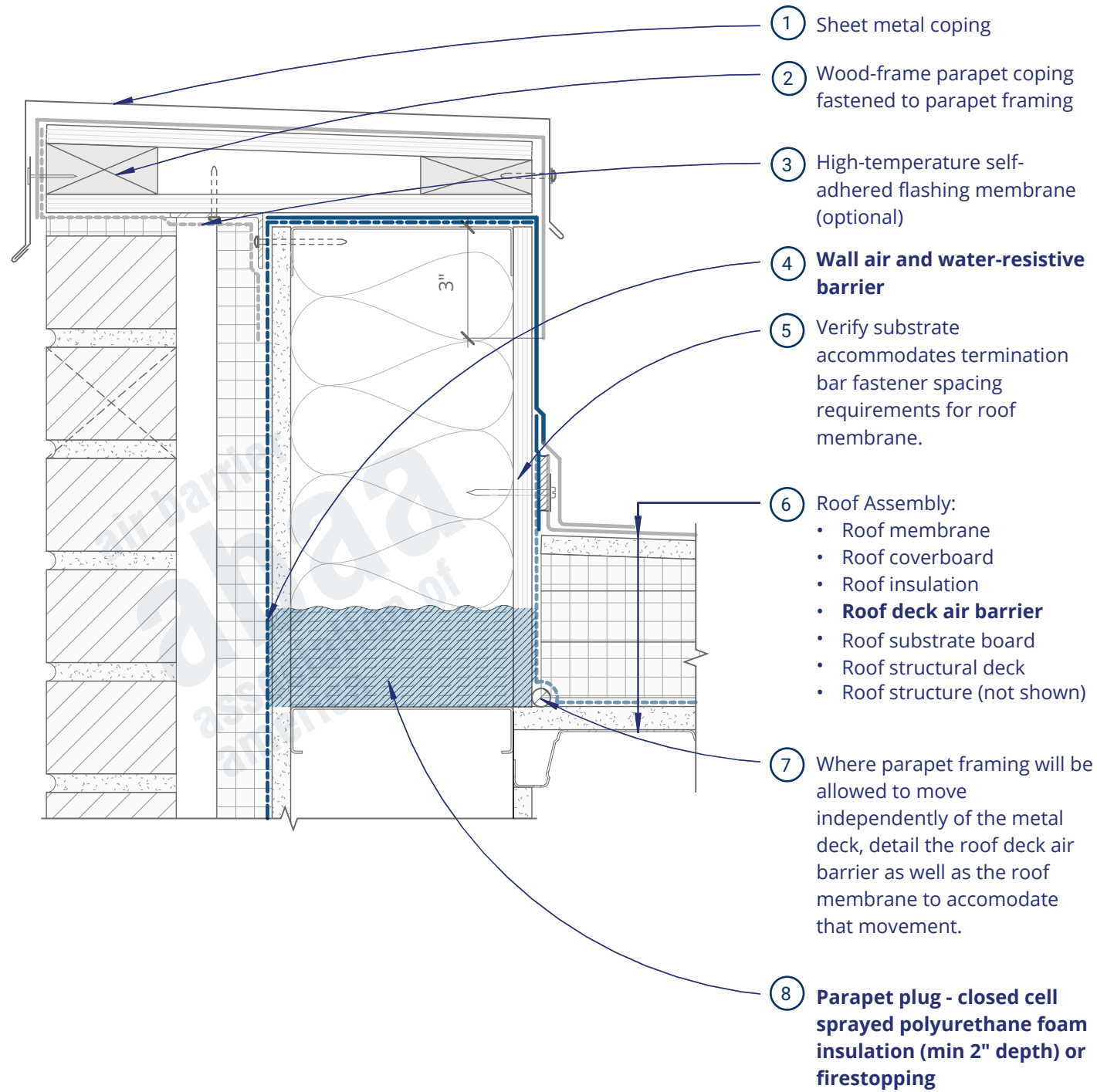

View from Roof

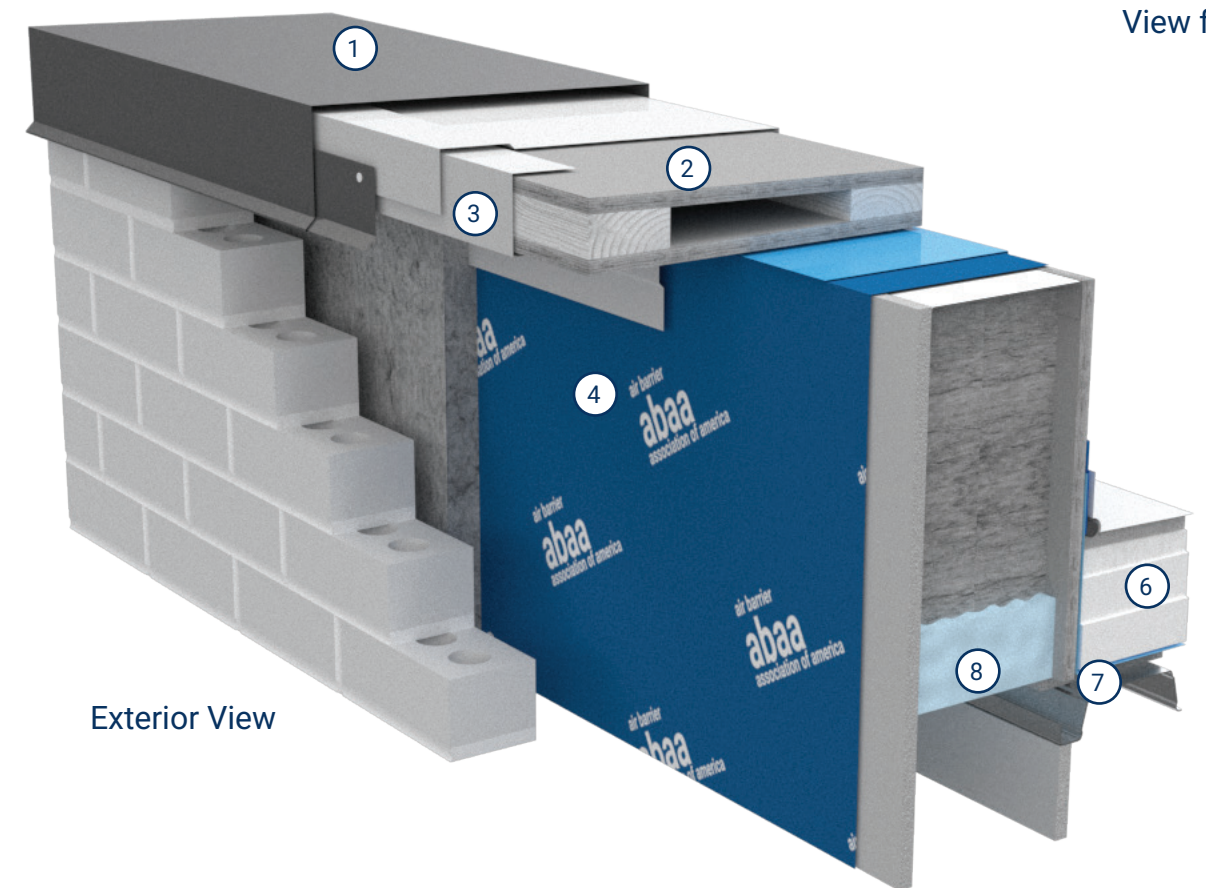

Exterior View

Rainscreen Wall - Parapet With Foam Insulation Base Plug at Deck (3D)

Detail RS4

Rainscreen Wall - Parapet With Continuous Rigid Board Exterior Insulation (2D)

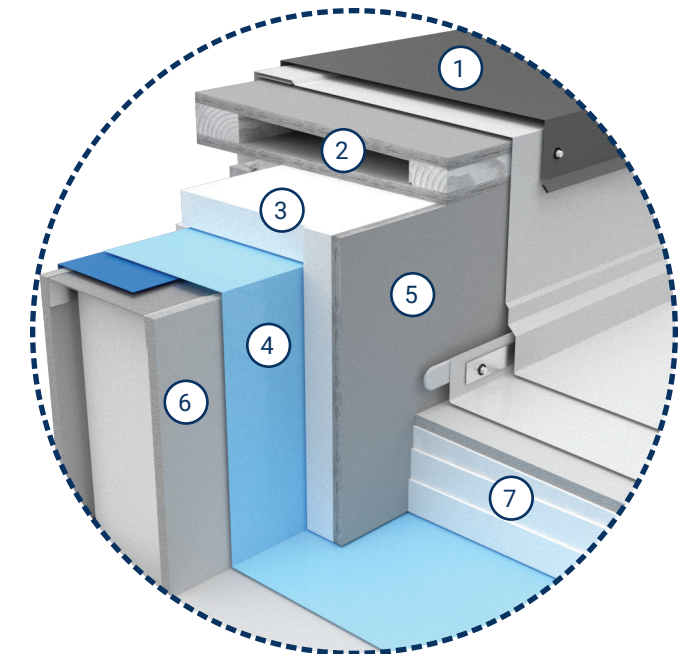
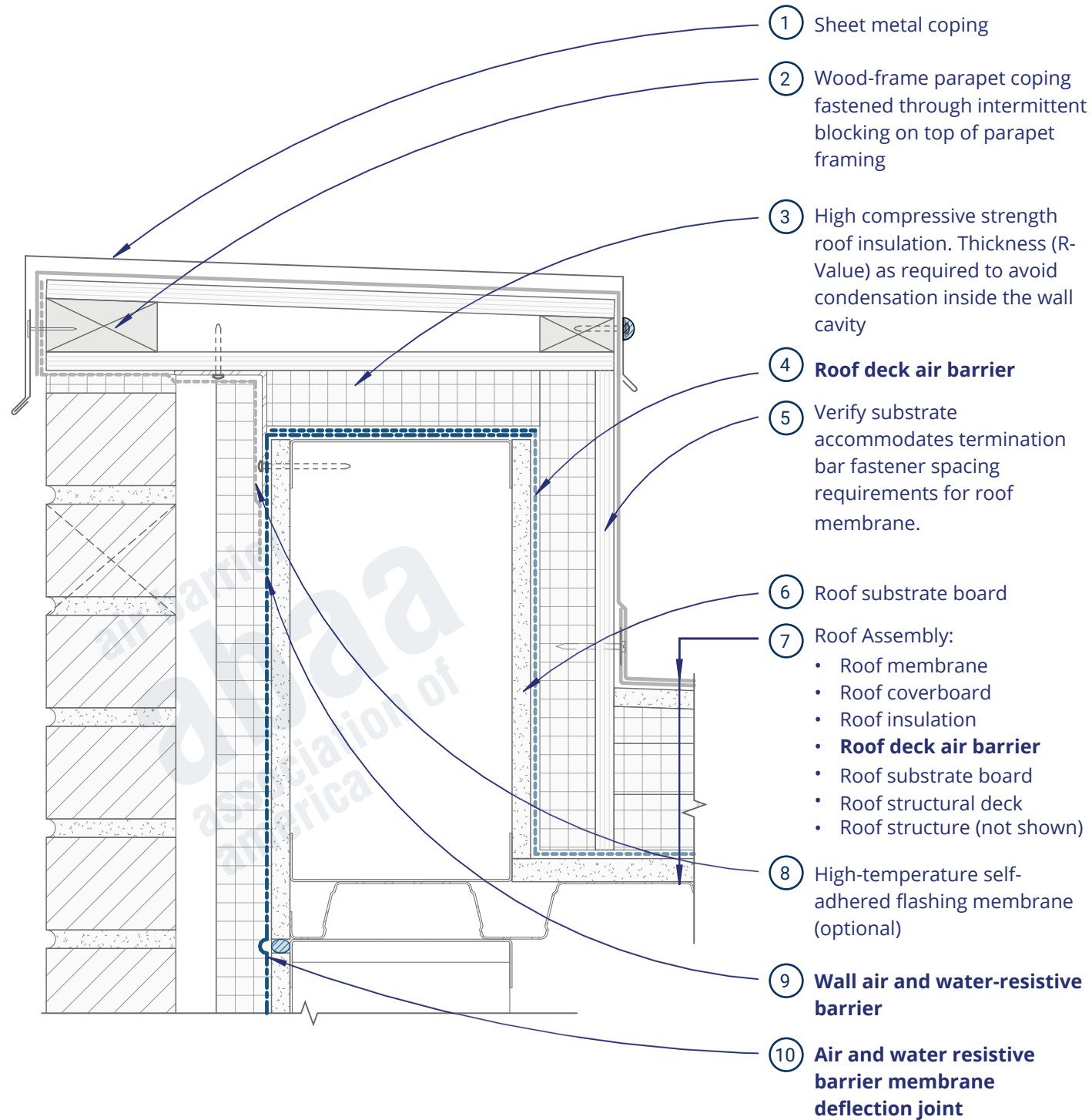

View from Roof

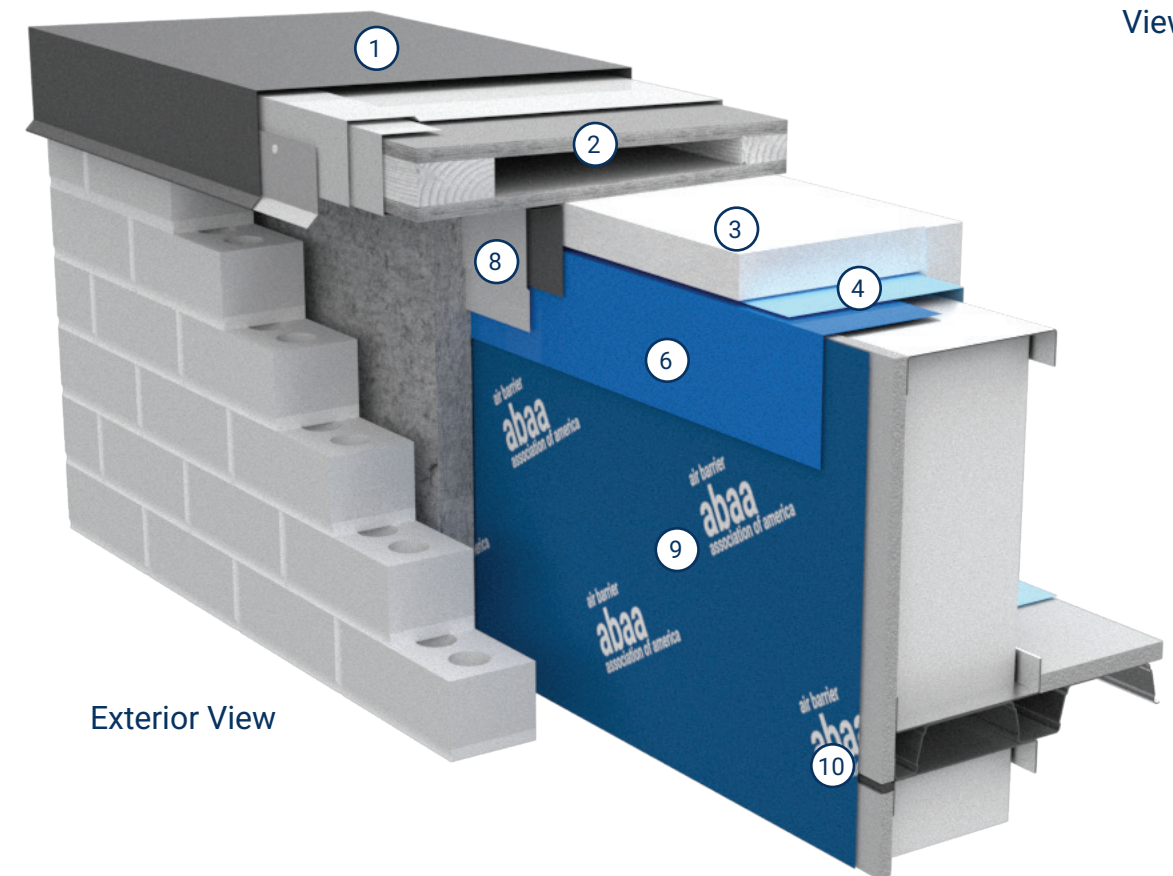

Exterior View

Rainscreen Wall - Parapet With Continuous Rigid Board Exterior Insulation (3D)

Detail RS5

Rainscreen Wall - Parapet With Insulation within Coping Blocking Assembly (2D)

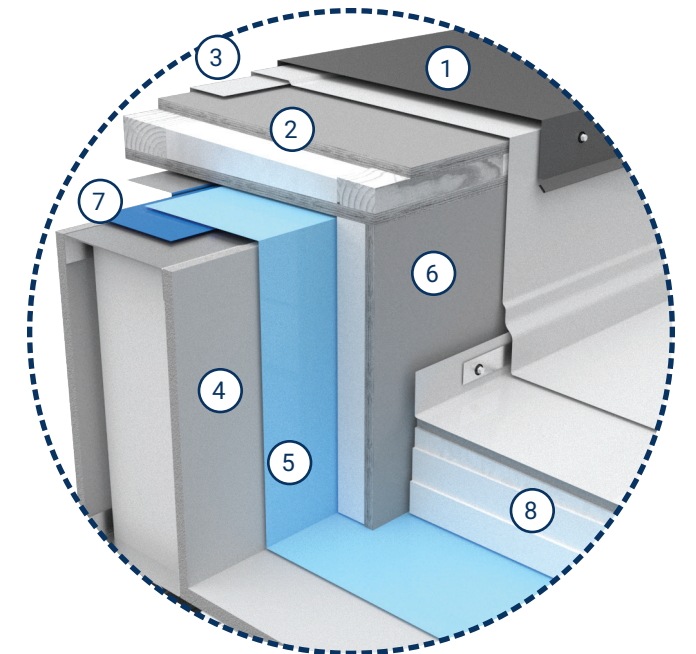
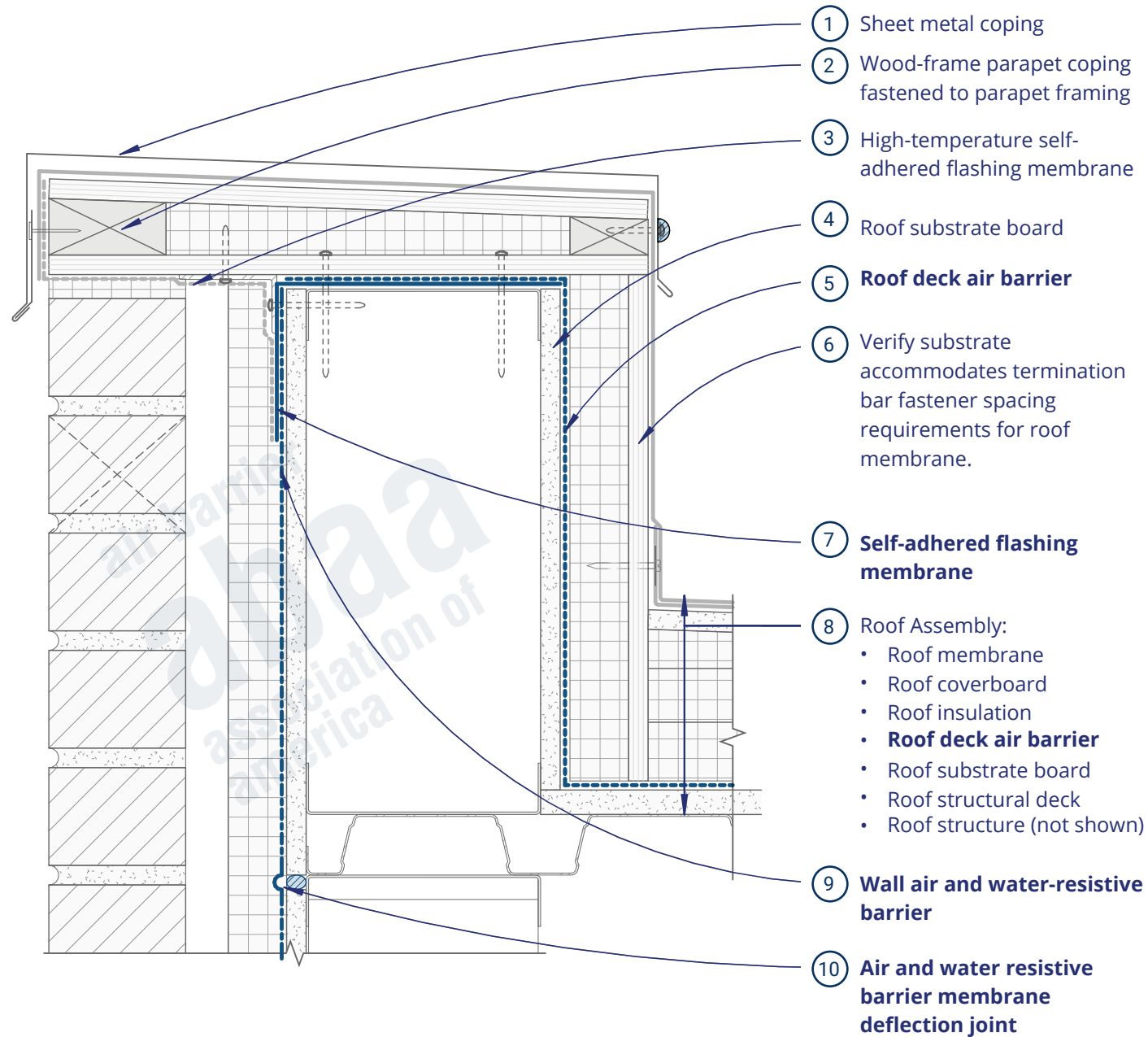

View from Roof

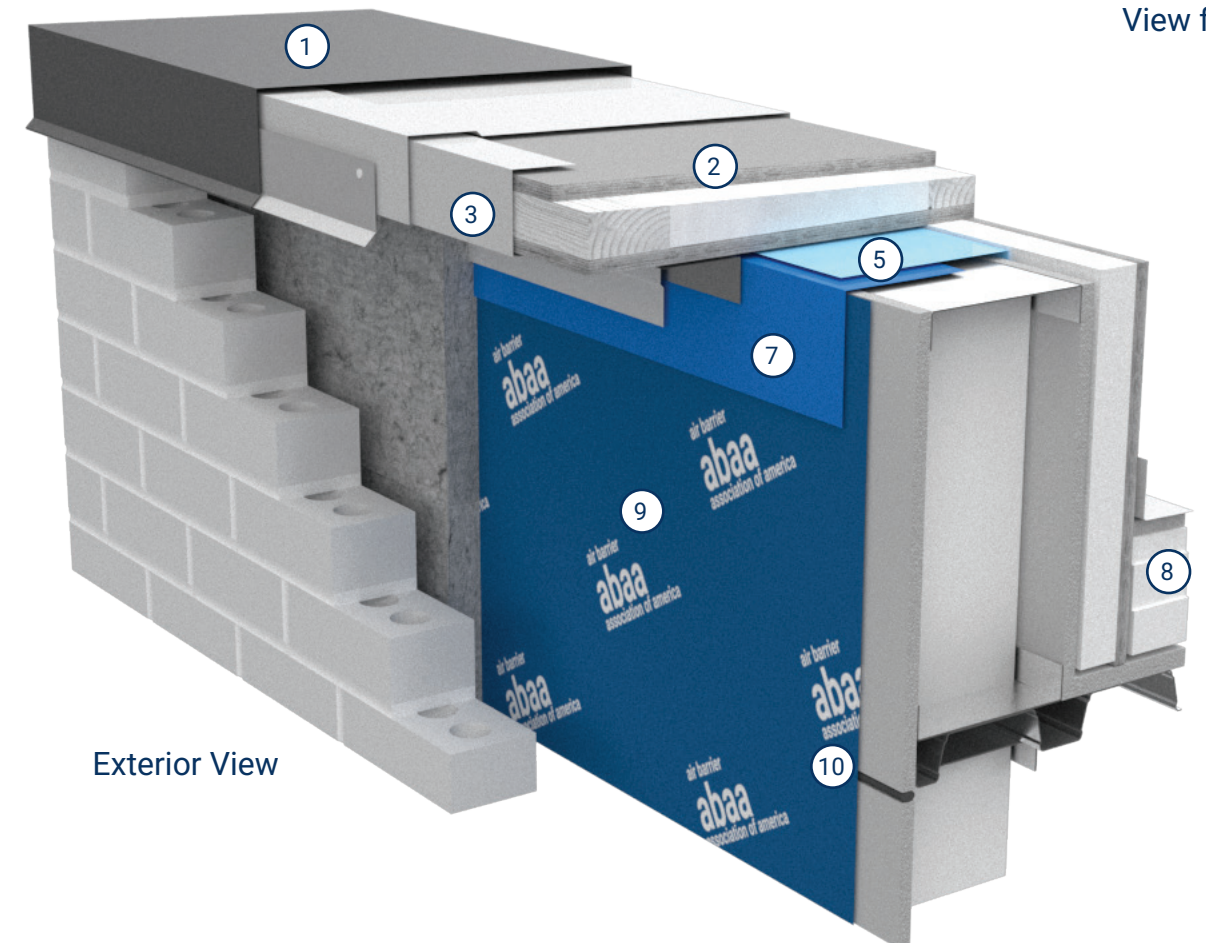

Exterior View

Rainscreen Wall - Parapet With Insulation within Coping Blocking Assembly (3D)

Detail RS6

Rainscreen Wall - Roof Deck Air Barrier Prior to Parapet Extension Without Thermal Break (2D)

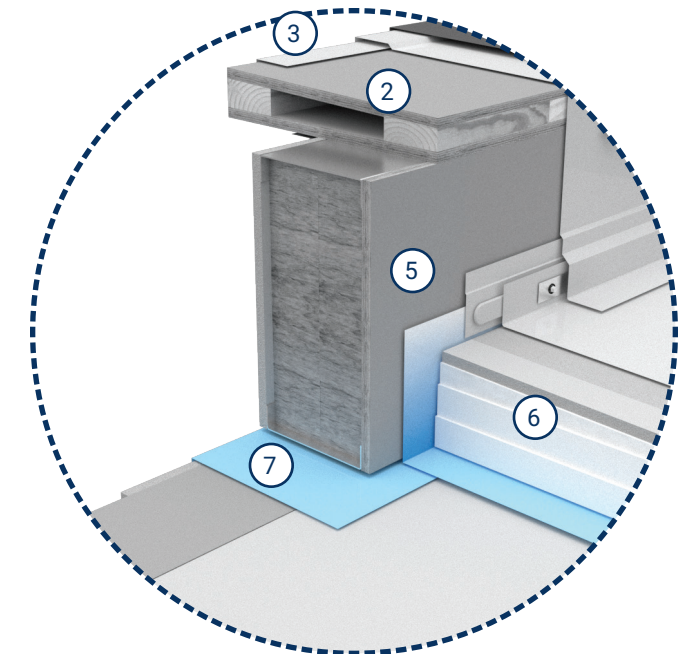
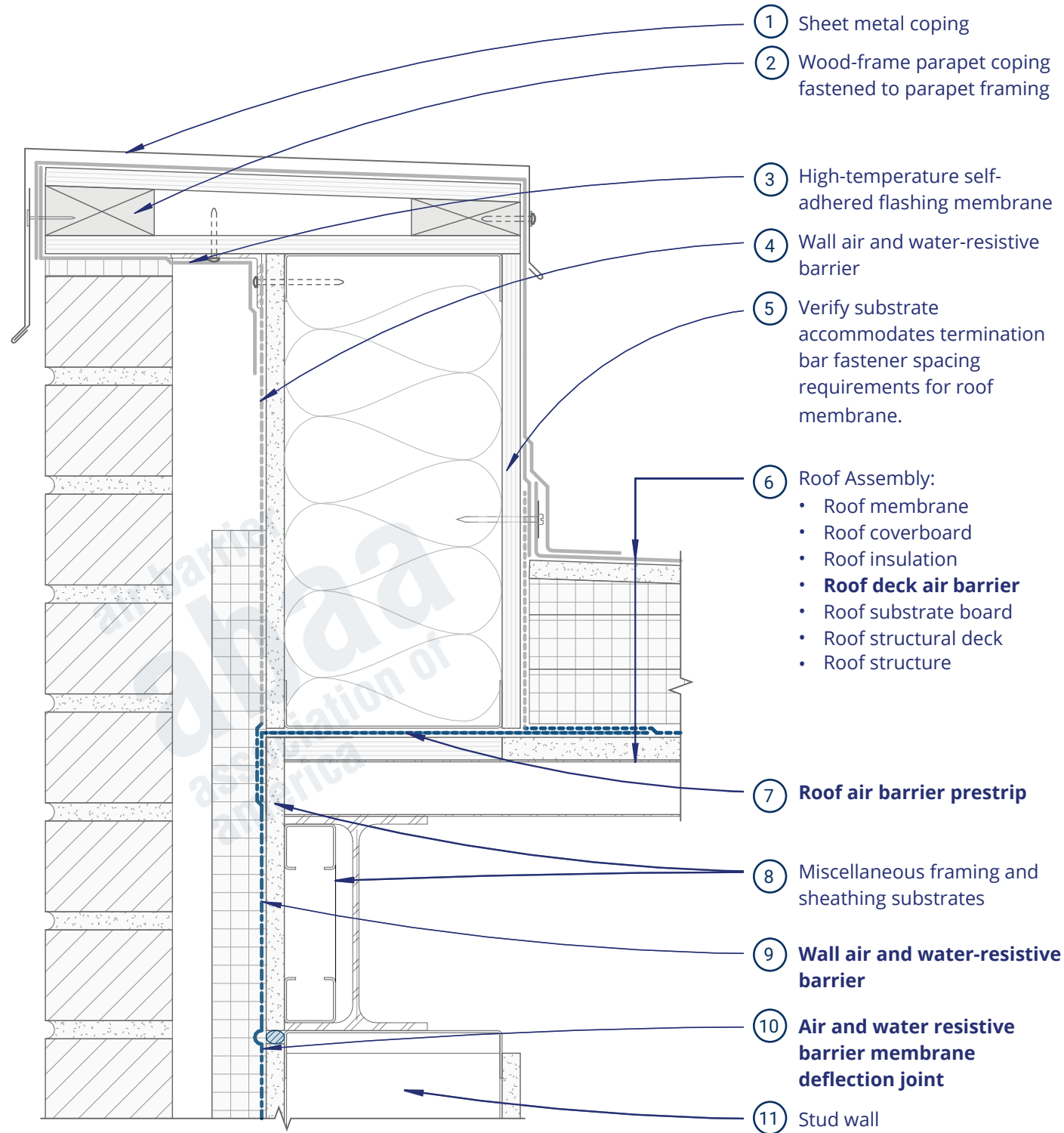

View from Roof

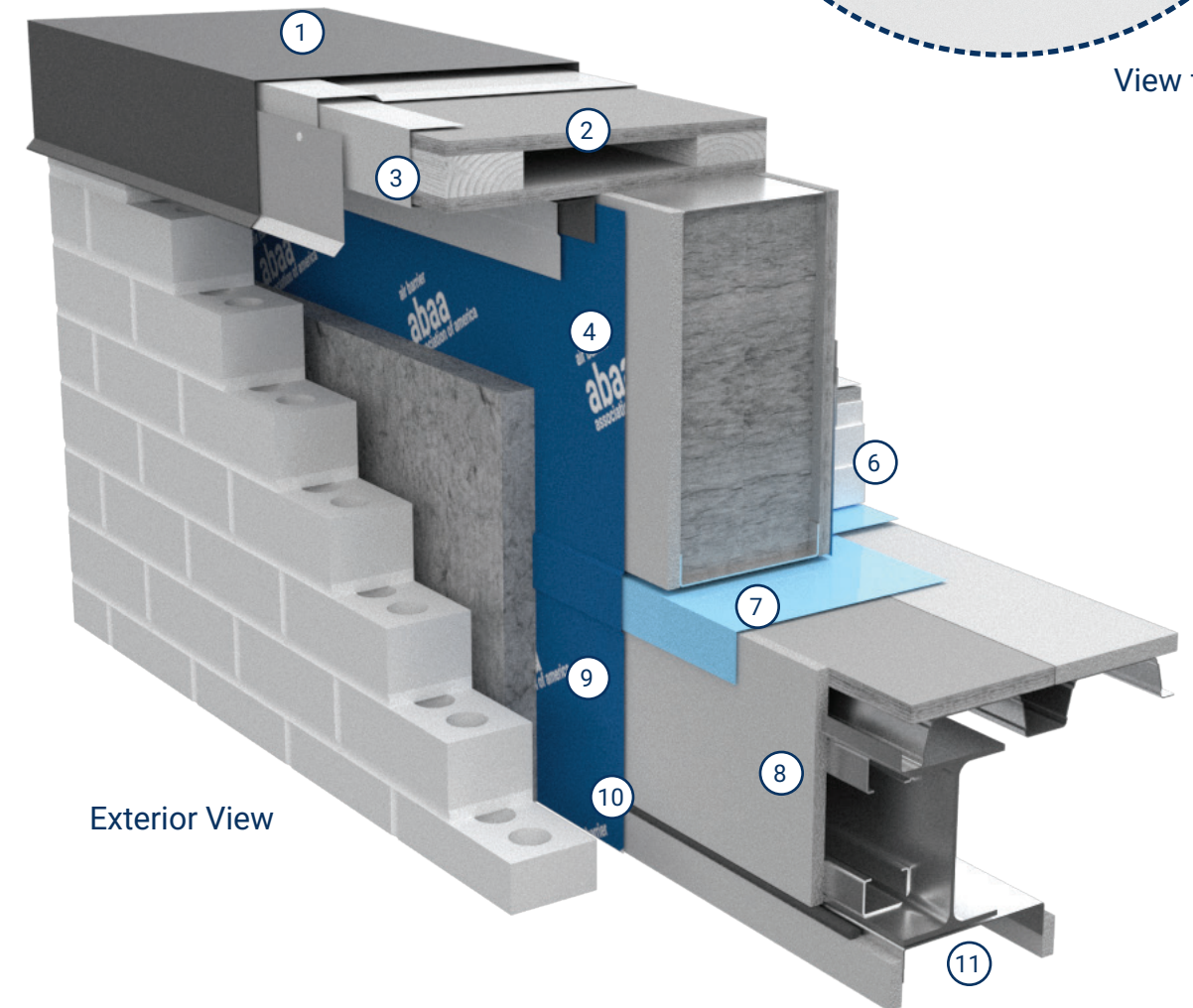

Exterior View

Rainscreen Wall - Roof Deck Air Barrier Prior to Parapet Extension Without Thermal Break (3D)

Parapet Details:
See General Notes sheet regarding parapet heights, condensation risk, and air and thermal continuity.

Detail RS8

Rainscreen Wall - Deck Air Barrier Prior to Parapet Extension With Thermal Break (2D)

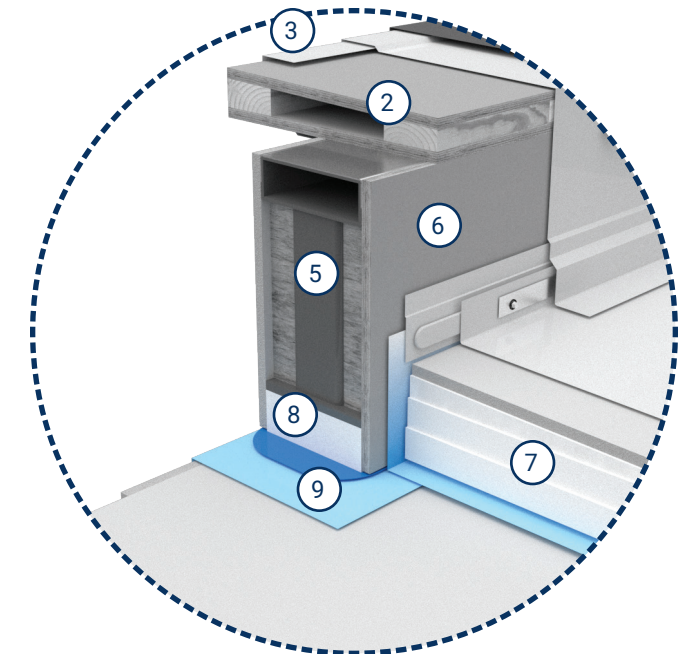
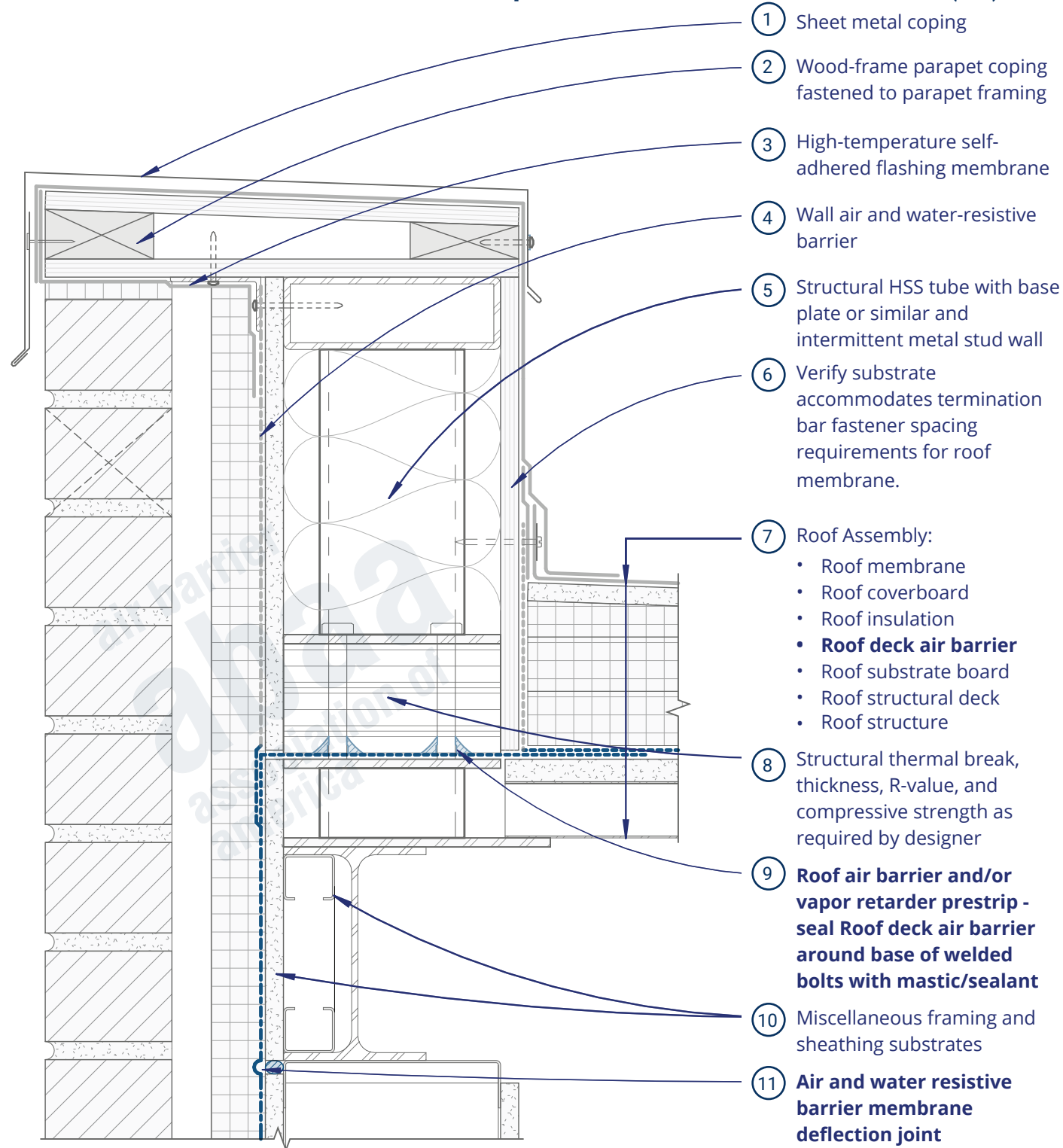

View from Roof

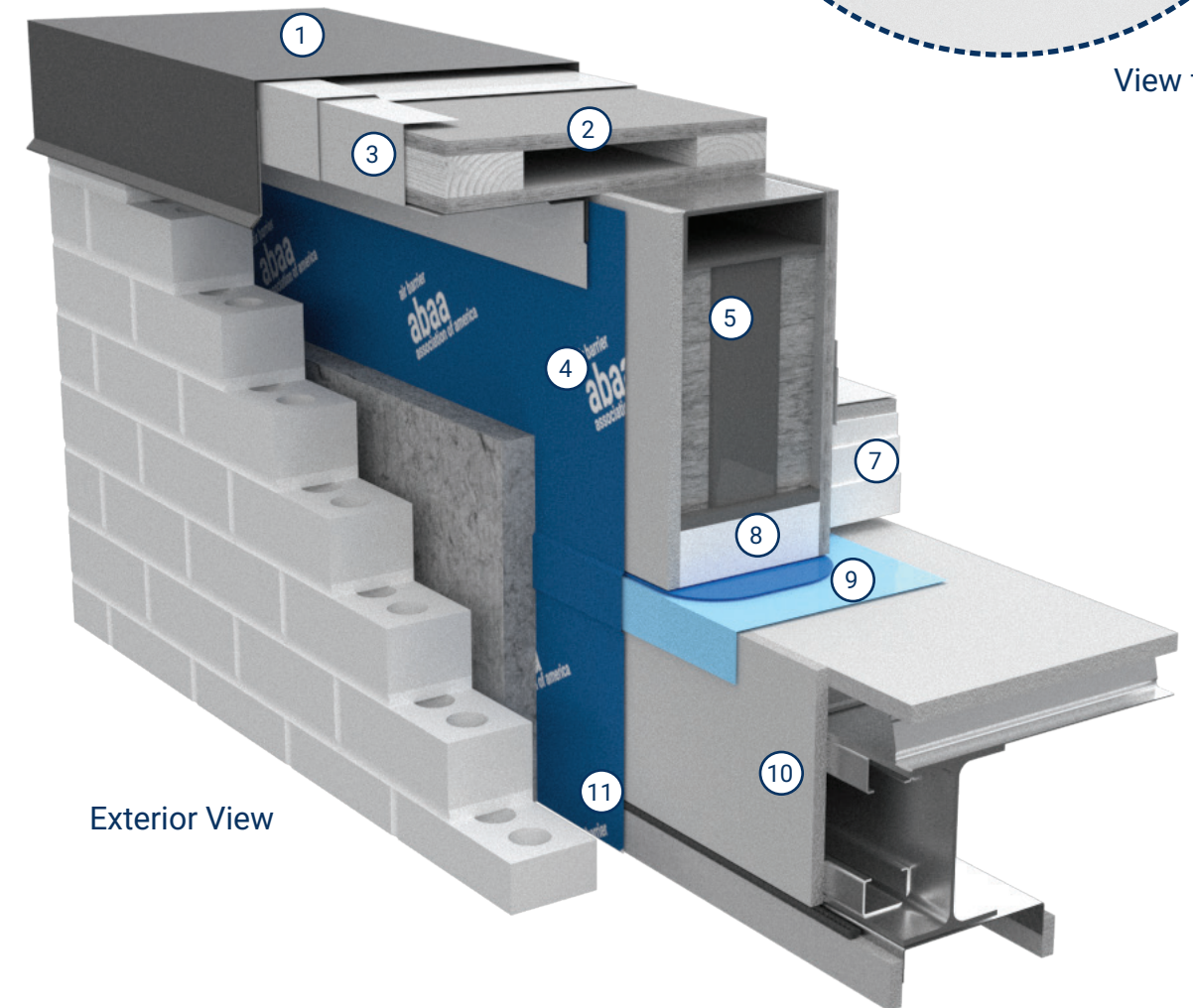

Exterior View

Rainscreen Wall - Deck Air Barrier Prior to Parapet Extension With Thermal Break (3D)

Detail IRS1

Insulated Sheathing Rainscreen Wall - Roof Edge Without Roof Deck Air Barrier (2D)

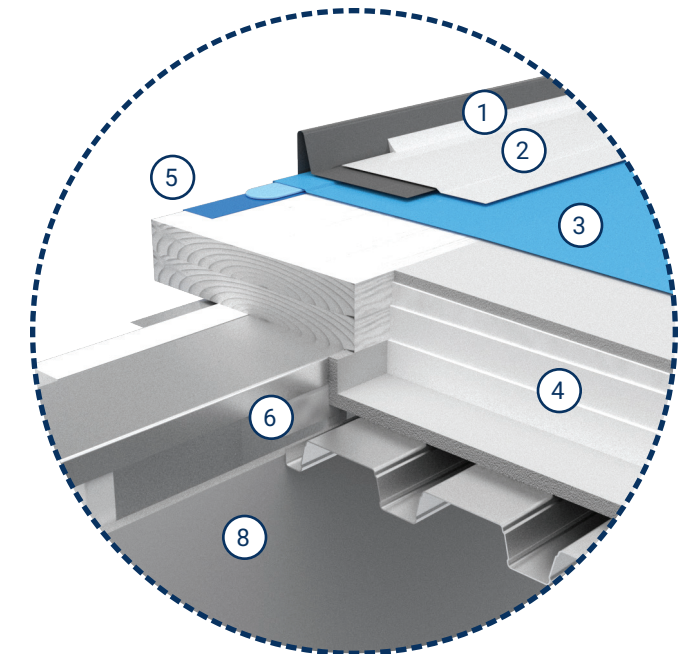
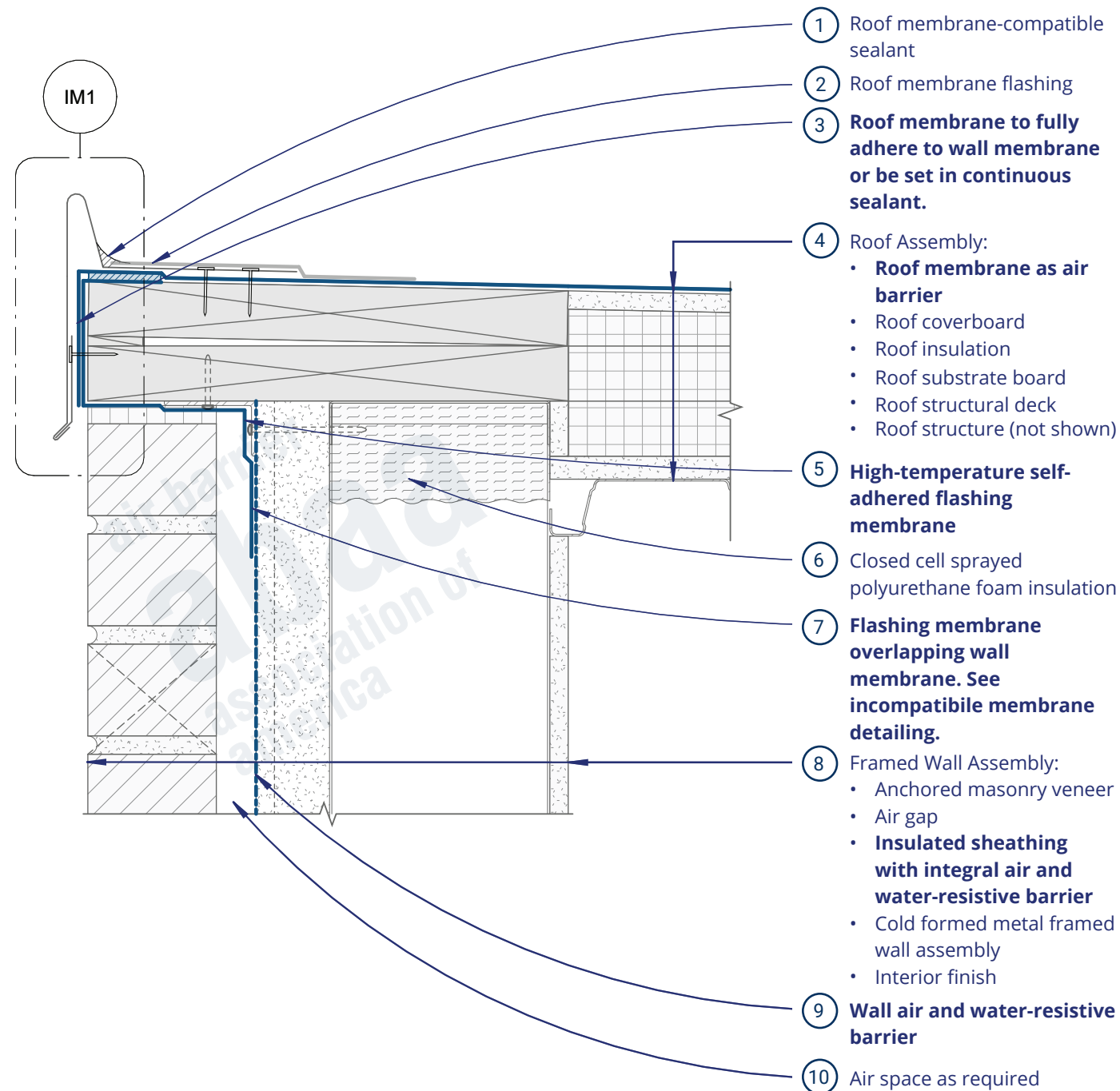

View from Roof

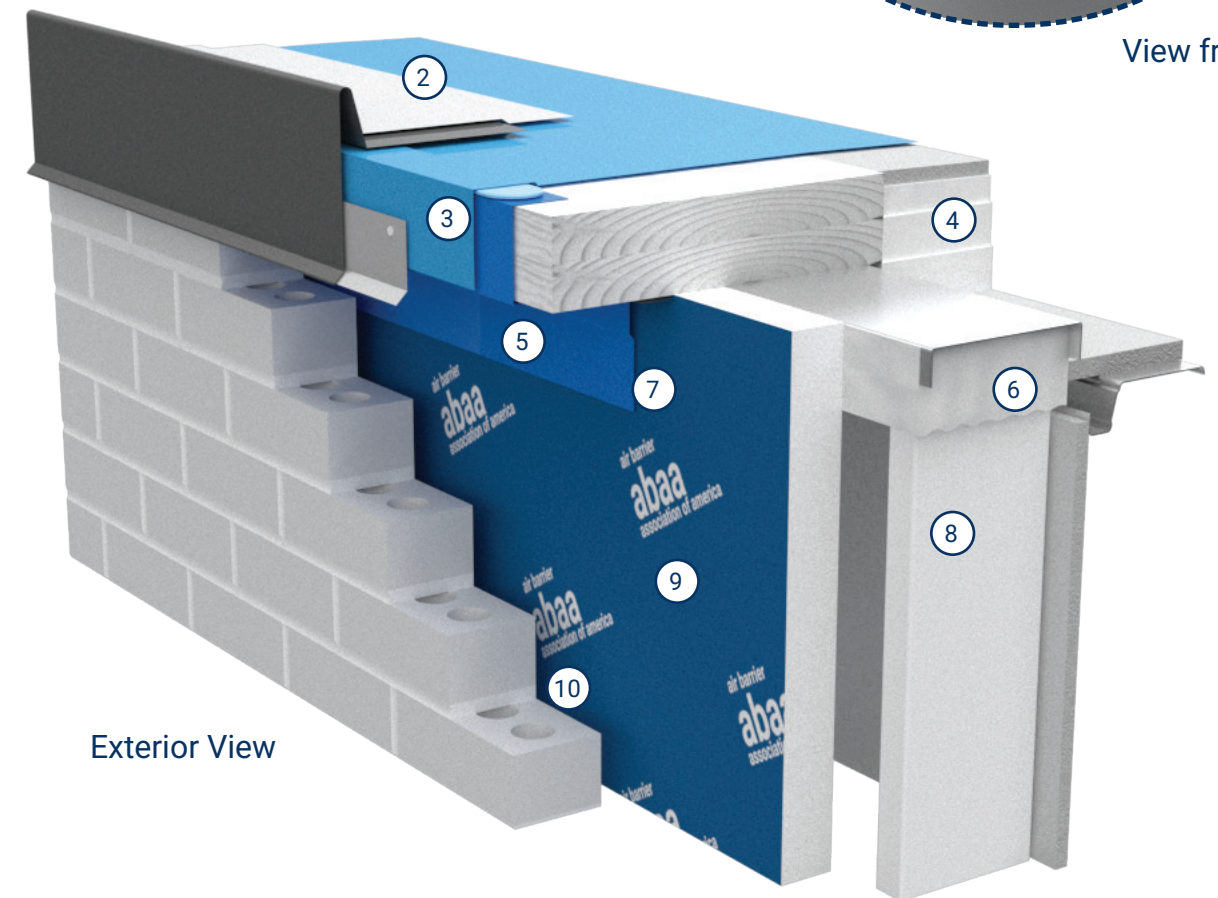

Exterior View

Insulated Sheathing Rainscreen Wall - Roof Edge Without Roof Deck Air Barrier (3D)

Detail IRS2

Insulated Sheathing Rainscreen Wall - Roof With Roof Deck Air Barrier (2D)

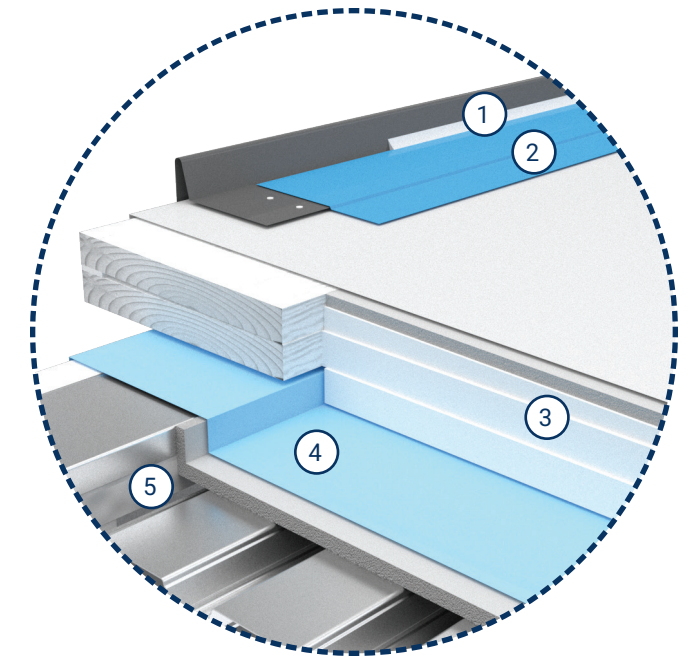
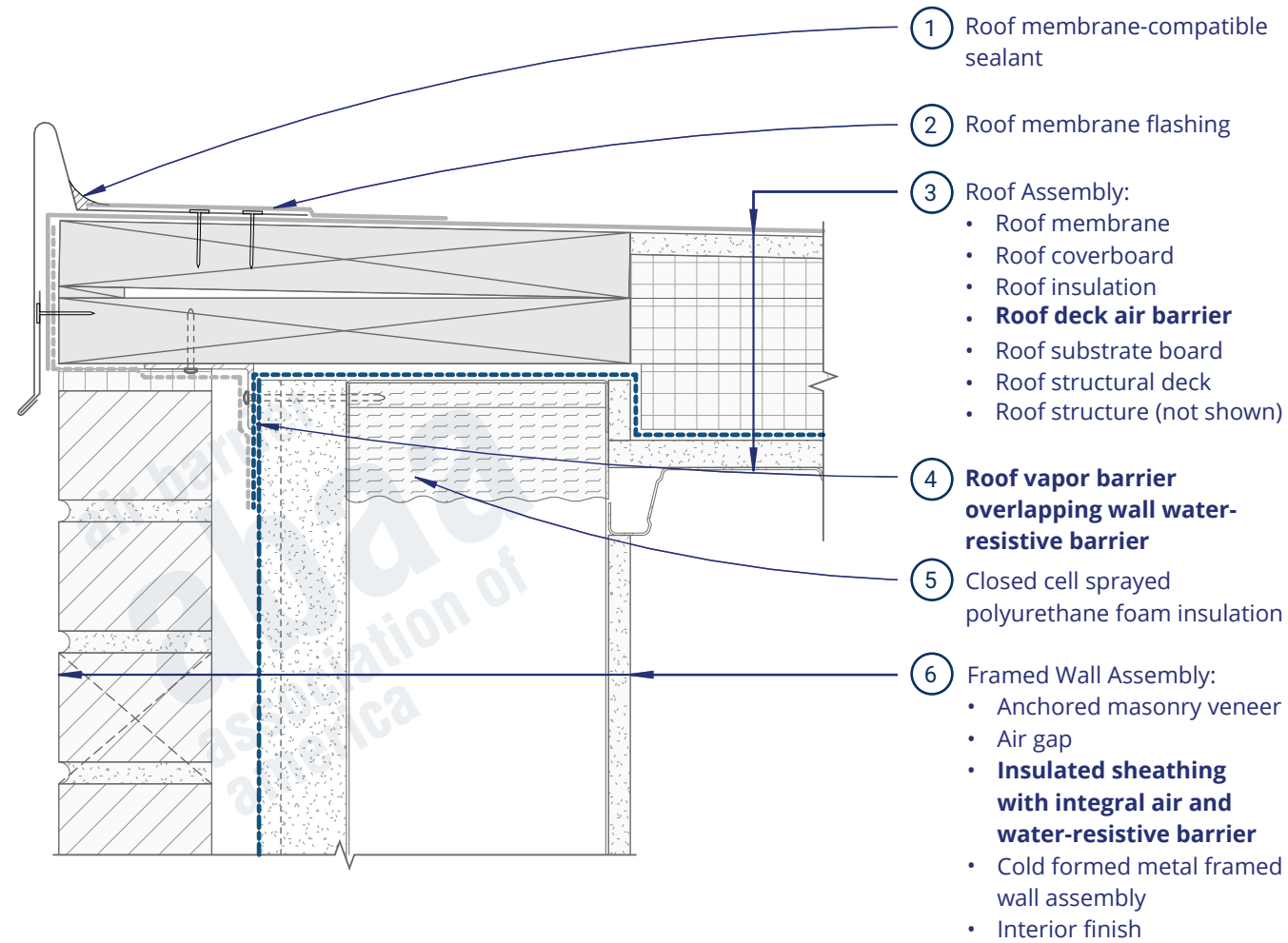

View from Roof

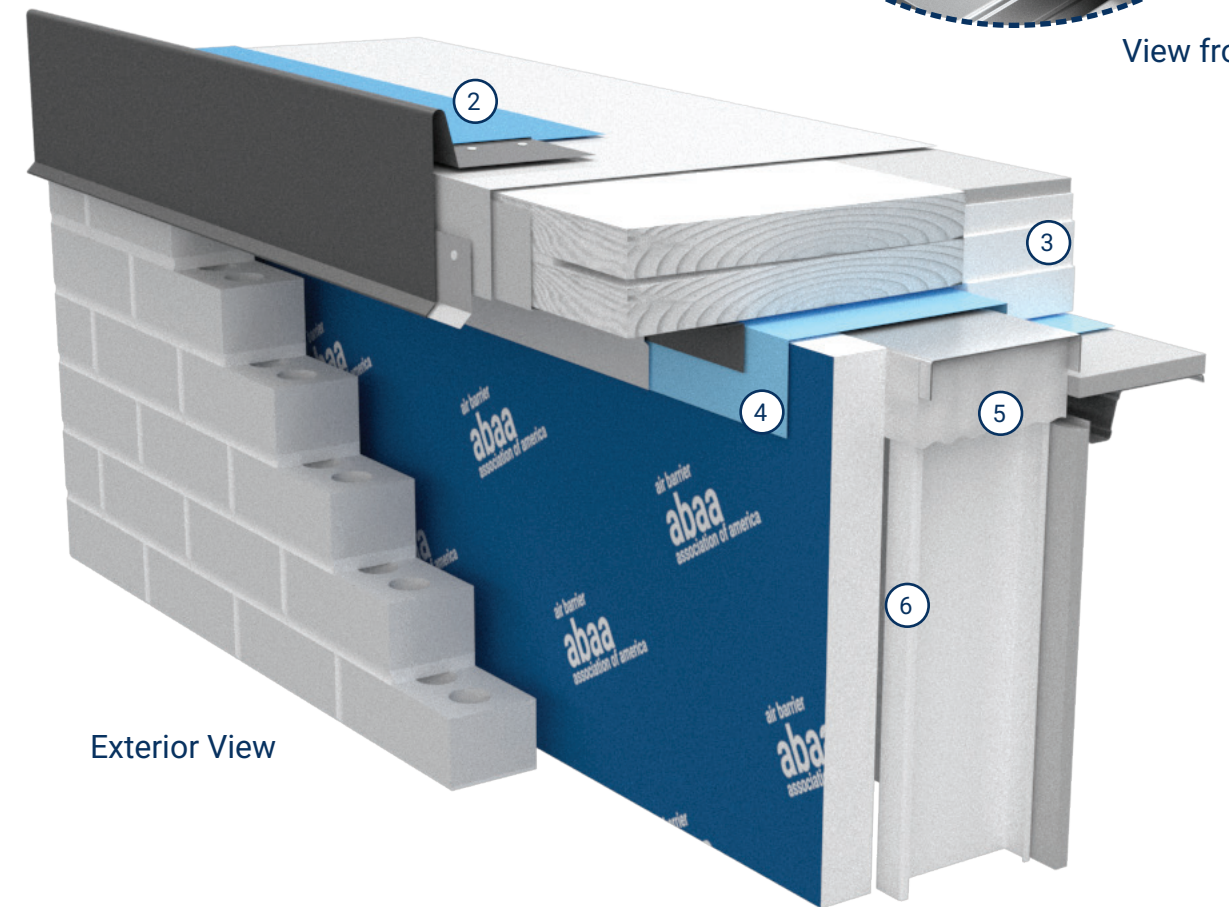

Exterior View

Insulated Sheathing Rainscreen Wall - Roof With Roof Deck Air Barrier (3D)

Detail IRS3

Insulated Sheathing Rainscreen Wall - Parapet With Foam Insulation Base Plug at Deck (2D)

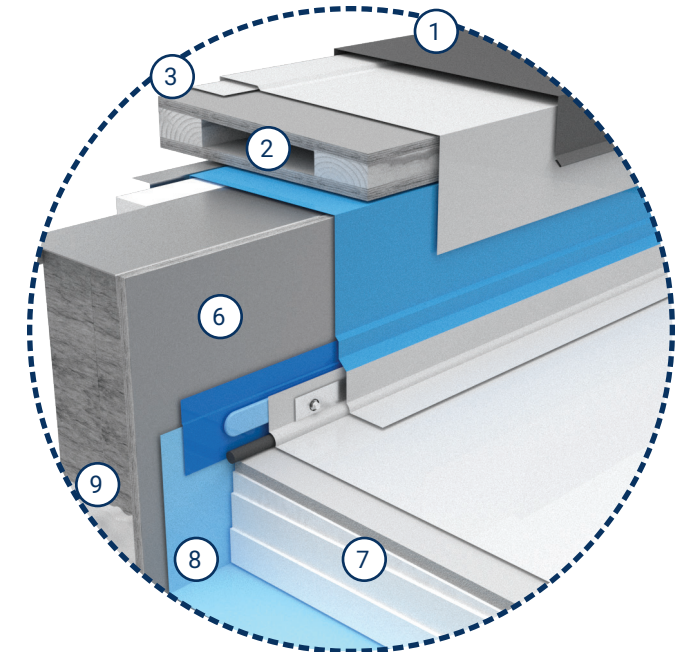
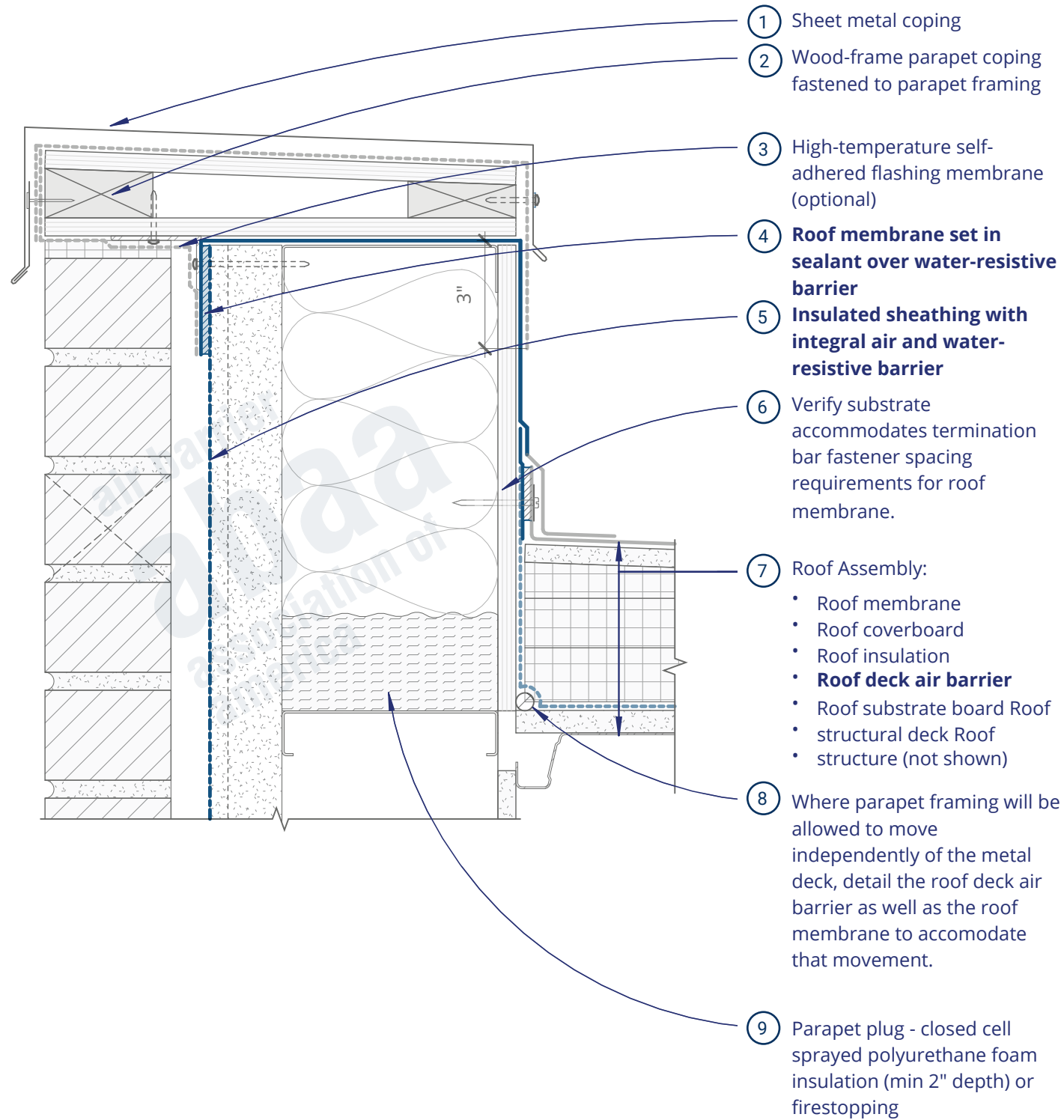

View from Roof

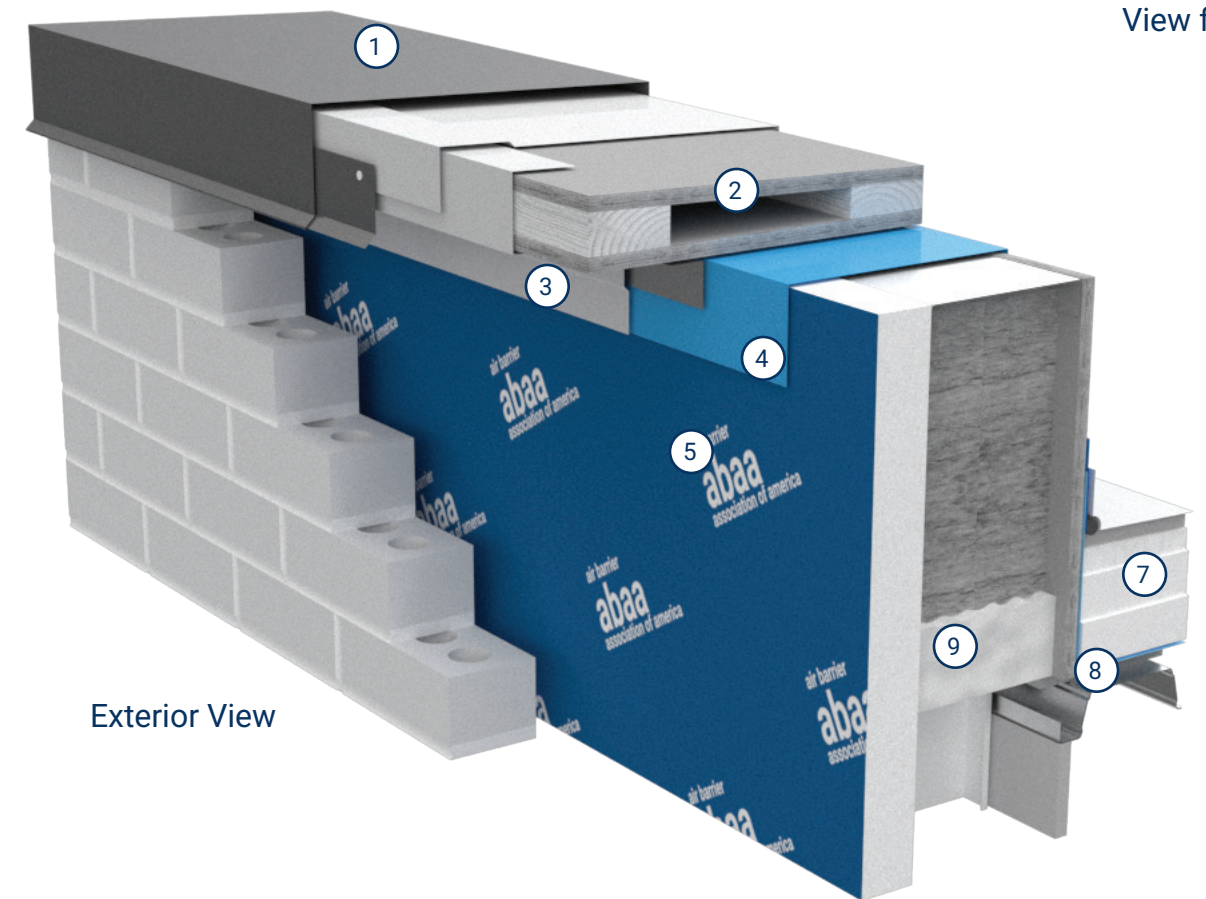

Exterior View

Insulated Sheathing Rainscreen Wall - Parapet With Foam Insulation Base Plug at Deck (3D)

Detail IRS4

Insulated Sheathing Rainscreen Wall - Parapet With Continuous Rigid Board Exterior Insulation (2D)

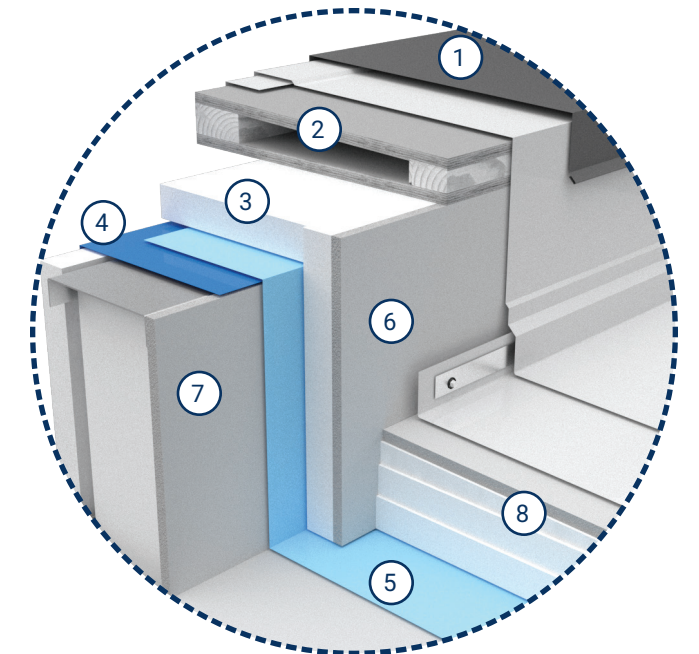
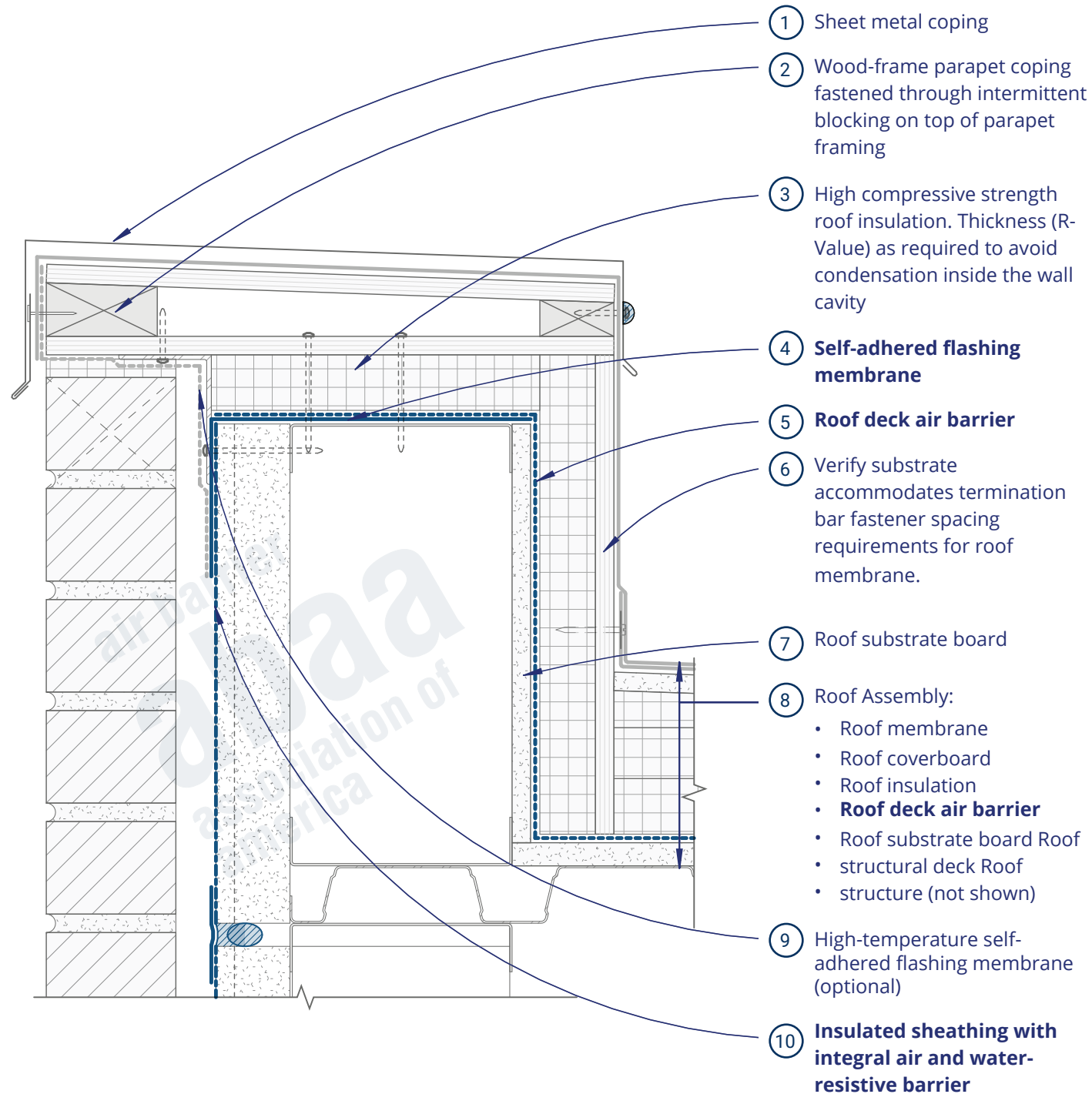

View from Roof

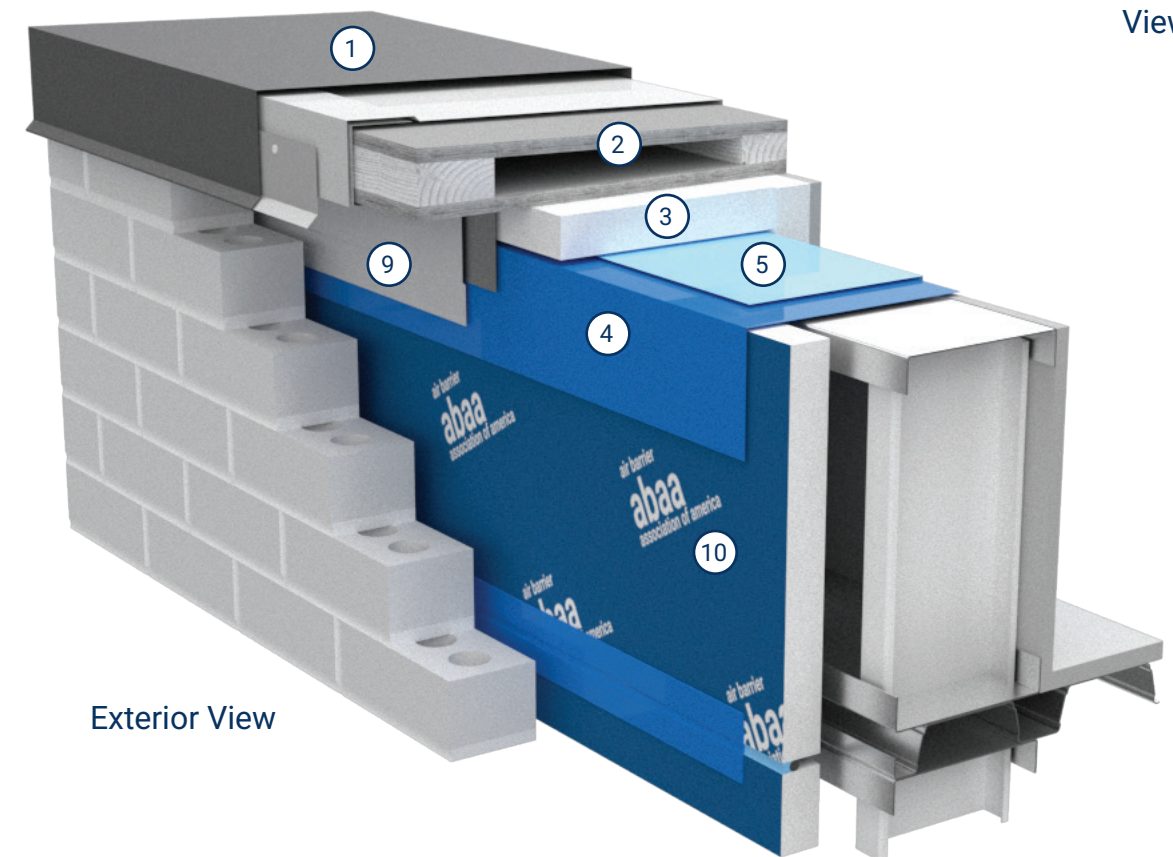

Exterior View

Insulated Sheathing Rainscreen Wall - Parapet With Continuous Rigid Board Exterior Insulation (3D)

Detail IRS5

Insulated Sheathing Rainscreen Wall - Parapet With Foam Insulation at Top of Parapet (2D)

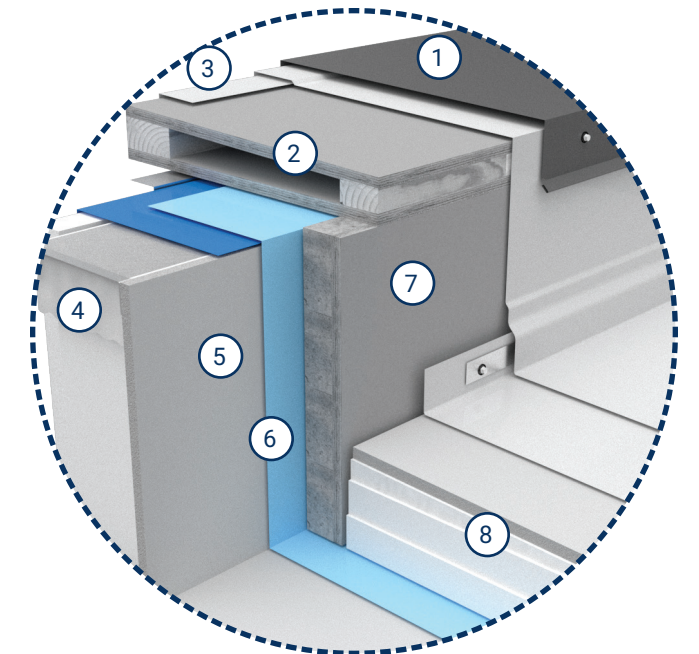
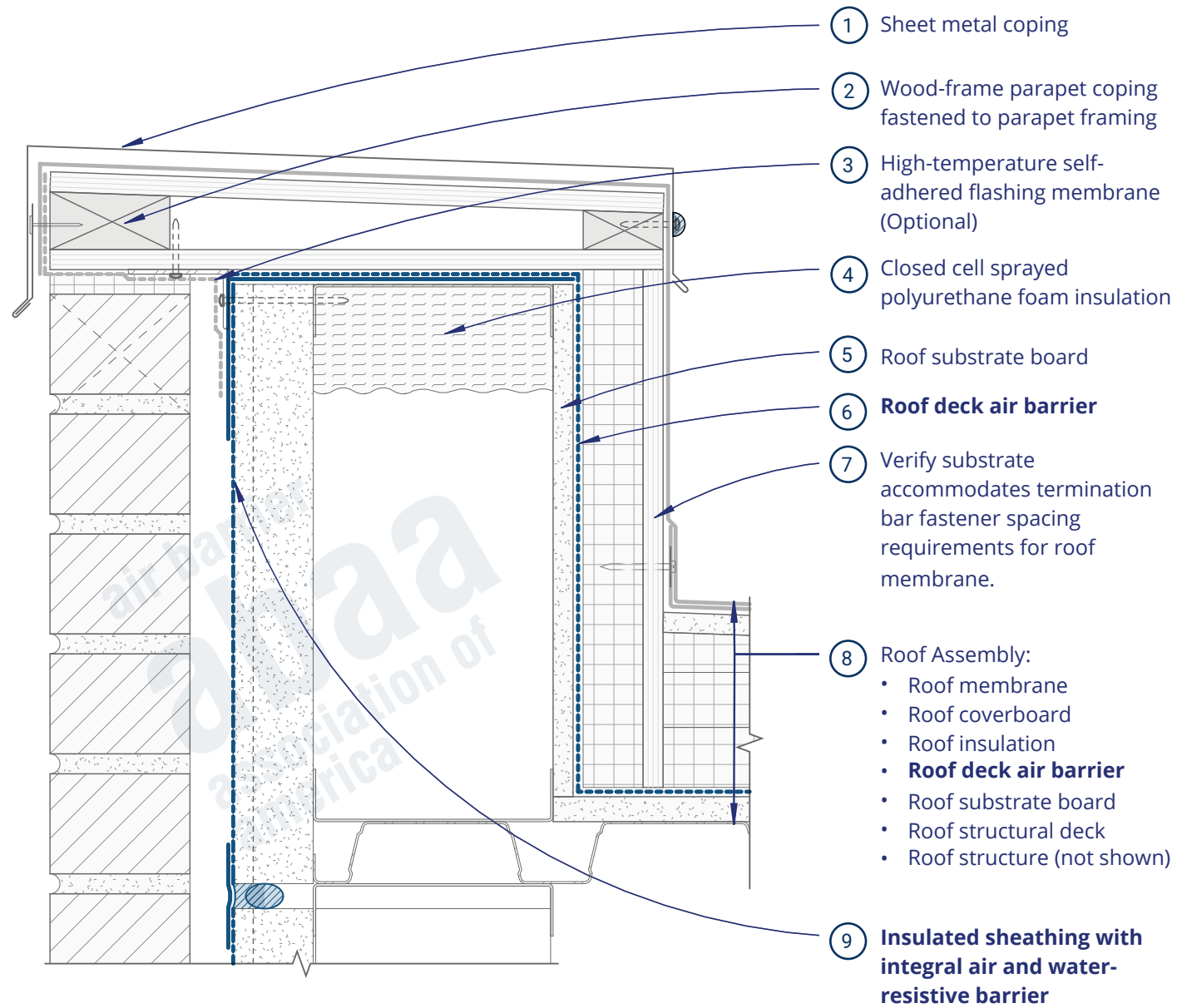

View from Roof

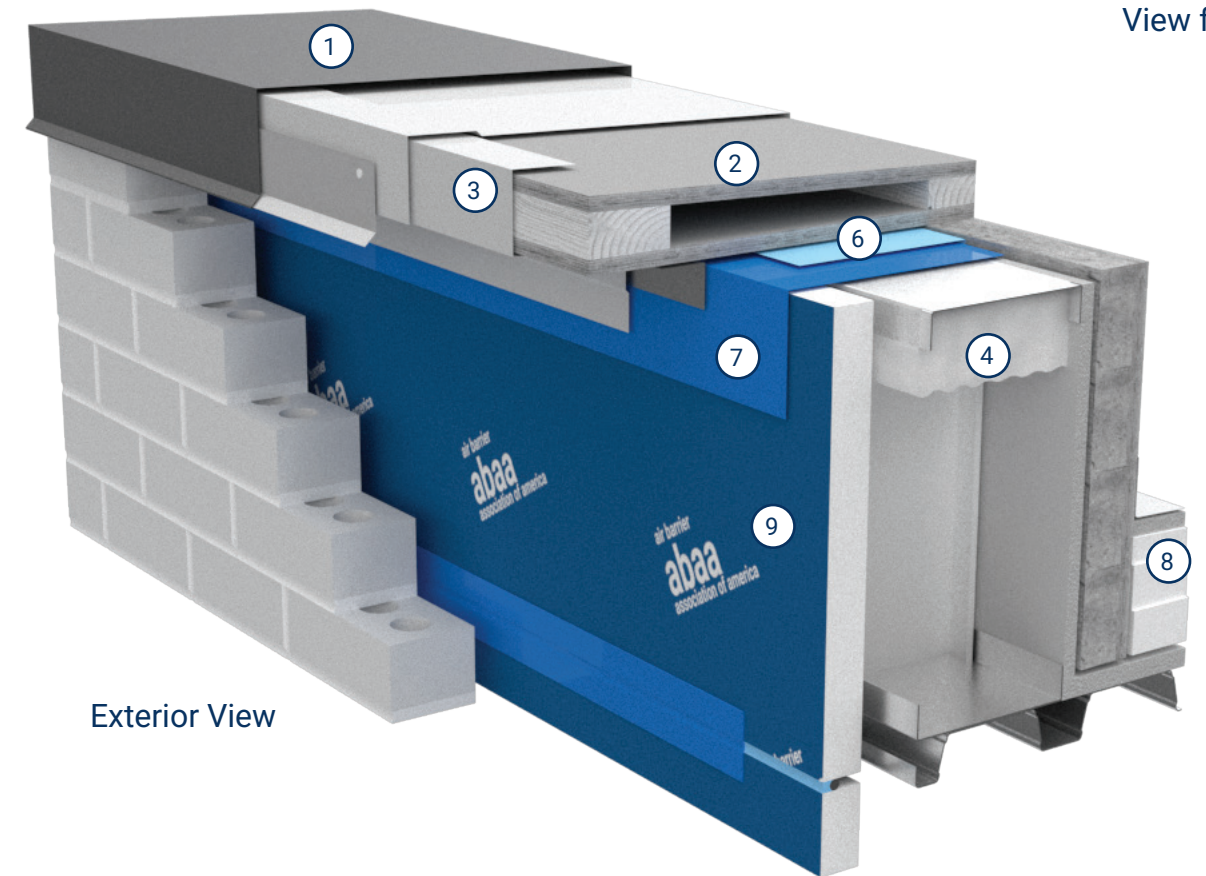

Exterior View

Insulated Sheathing Rainscreen Wall - Parapet With Foam Insulation at Top of Parapet (3D)

Detail IRS6

Insulated Sheathing Rainscreen Wall - Parapet With Insulation within Coping Blocking Assembly (2D)

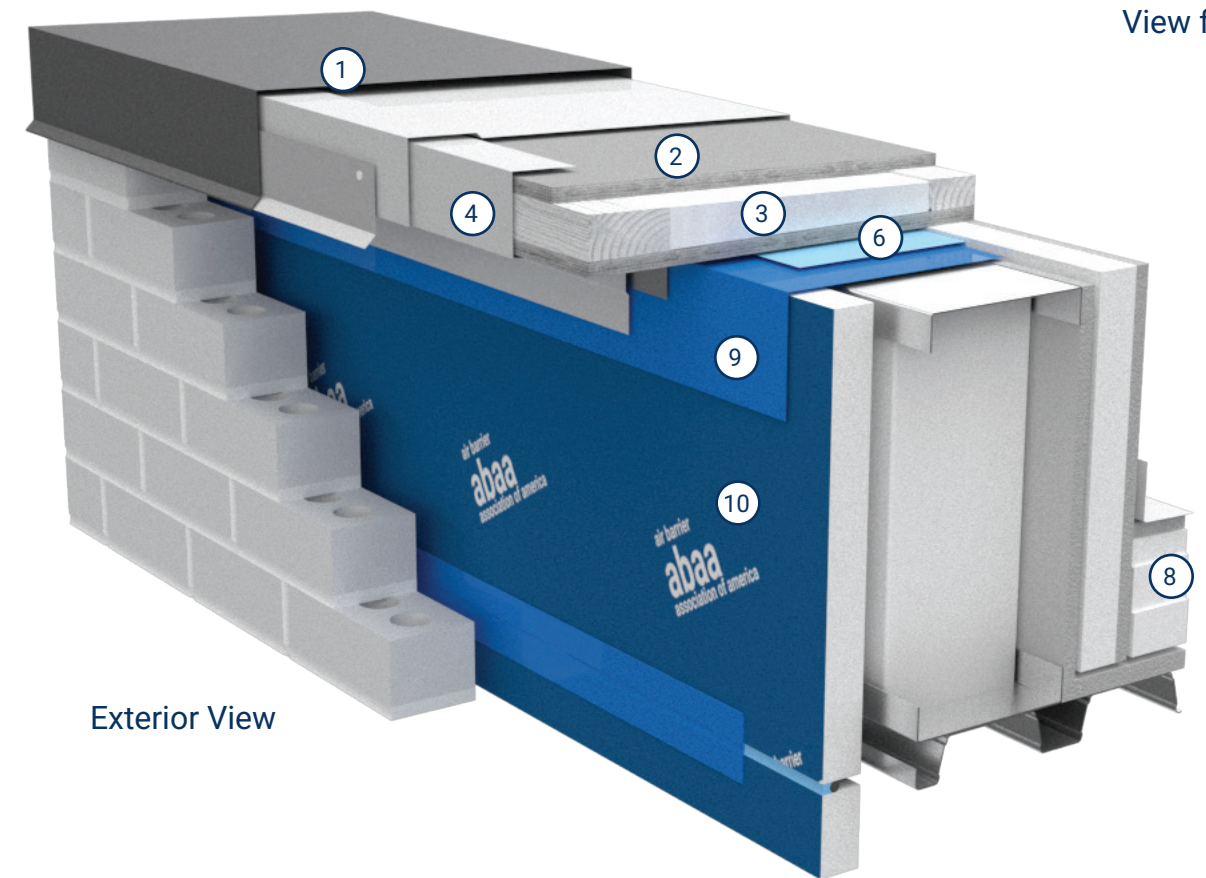
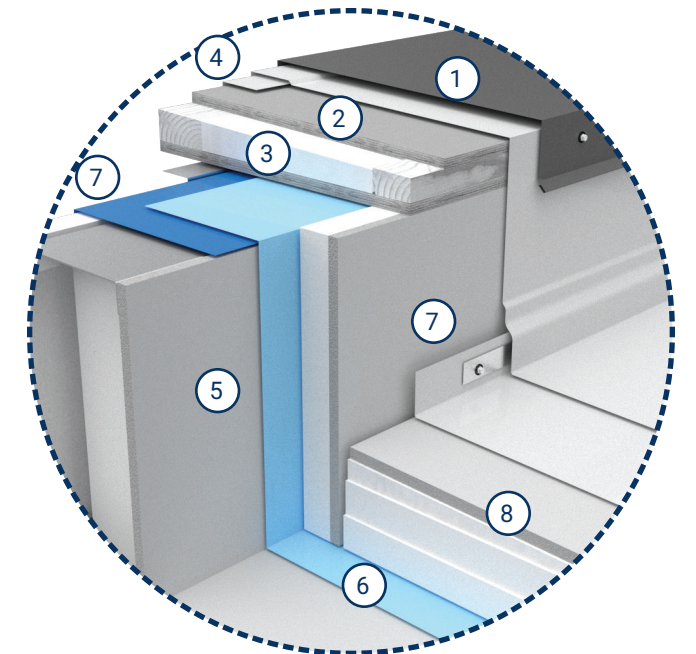
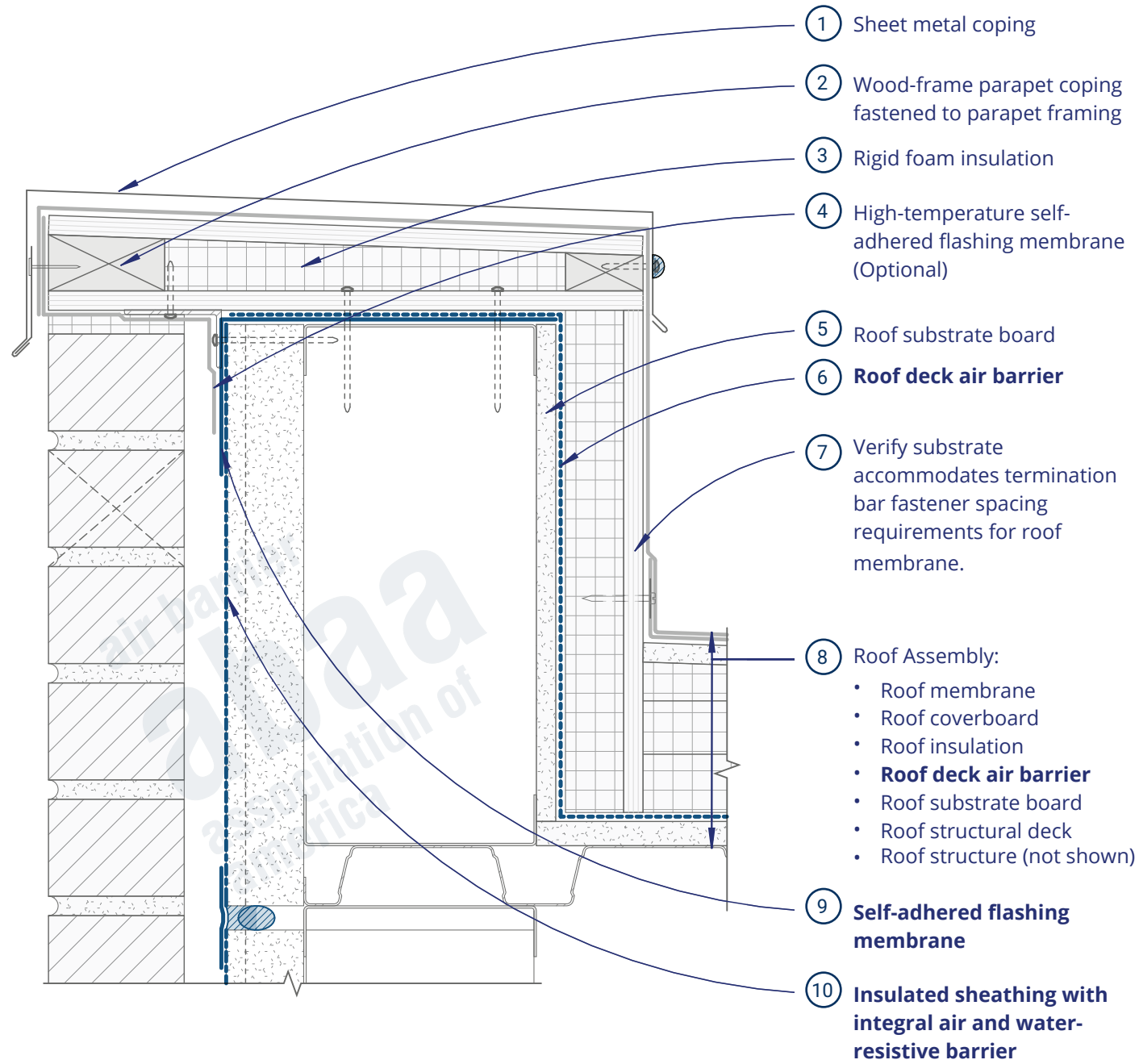

Insulated Sheathing Rainscreen Wall - Parapet With Insulation within Coping Blocking Assembly (3D)

Detail IRS7

Insulated Sheathing Rainscreen Wall - Air Barrier Installation Prior to Parapet Extension - Without Thermal Break (2D)

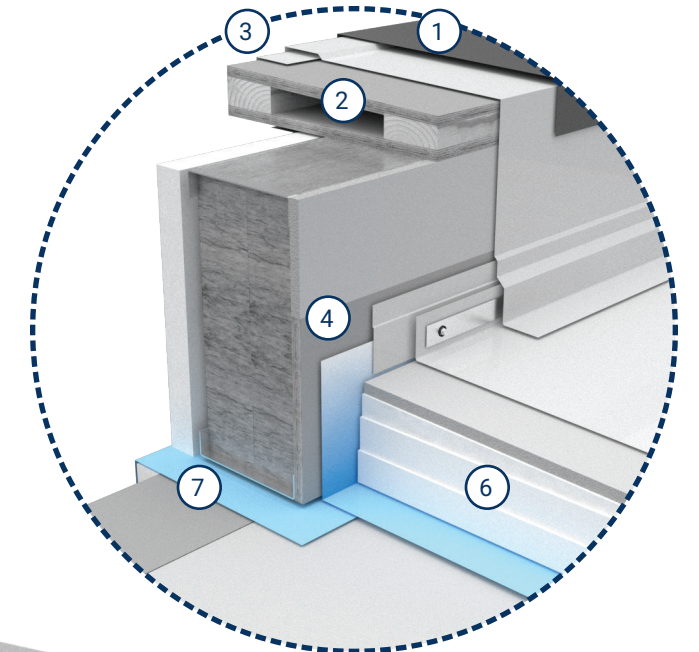
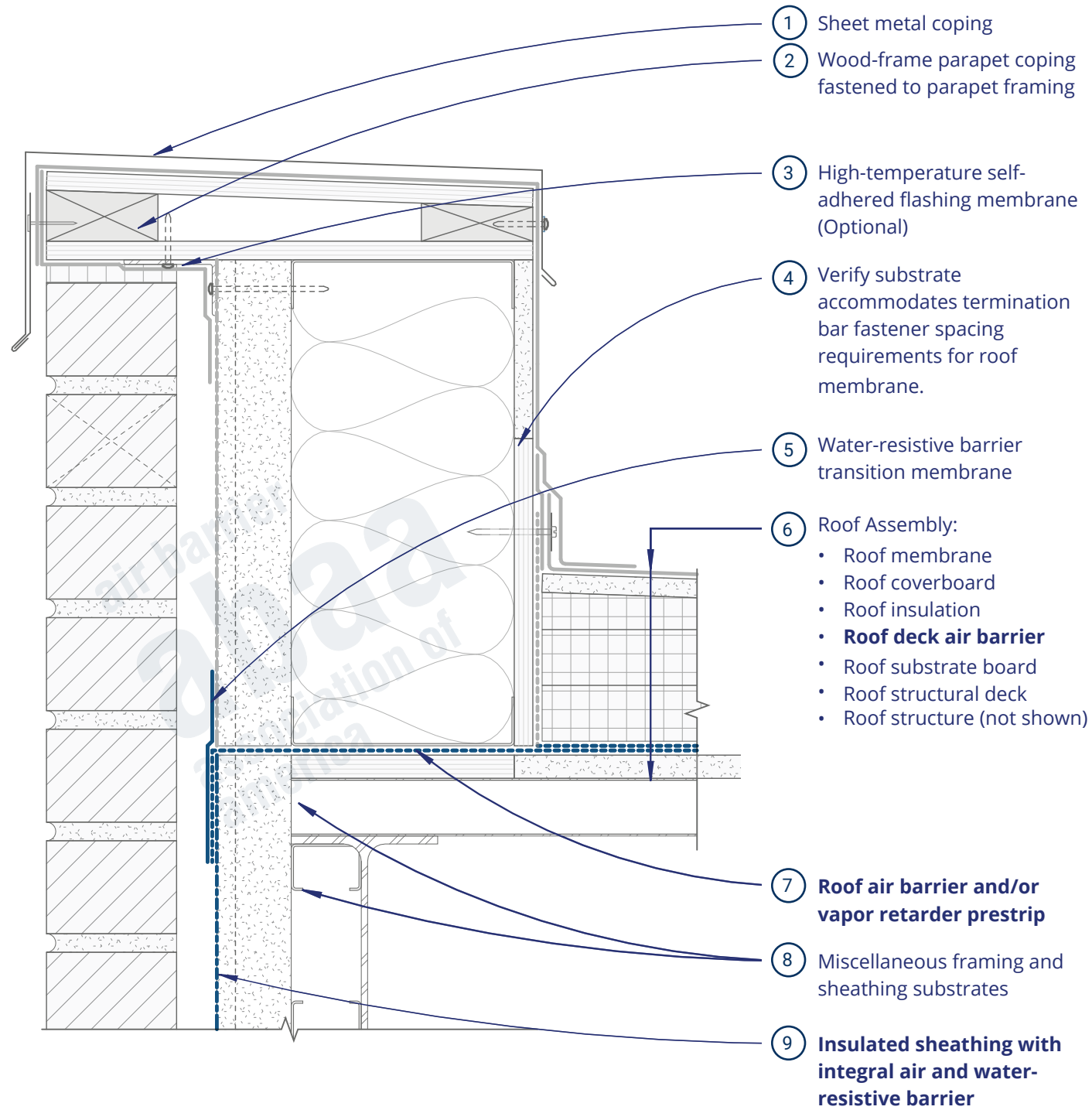

View from Roof

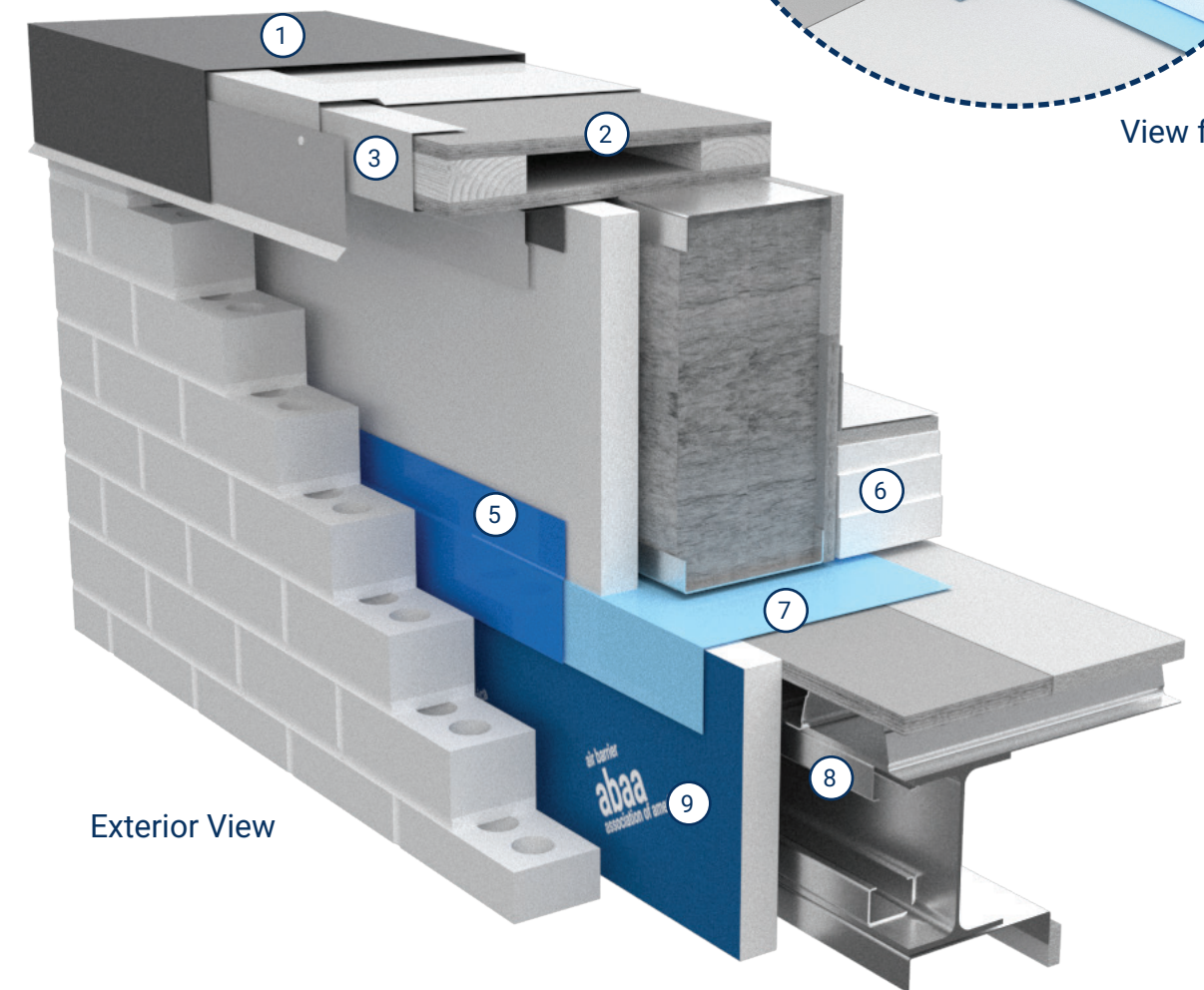

Exterior View

Insulated Sheathing Rainscreen Wall - Air Barrier Installation Prior to Parapet Extension - Without Thermal Break (3D)

Detail IRS8

Insulated Sheathing Rainscreen Wall - Air Barrier Installation Prior to Parapet Extension - With Thermal Break (2D)

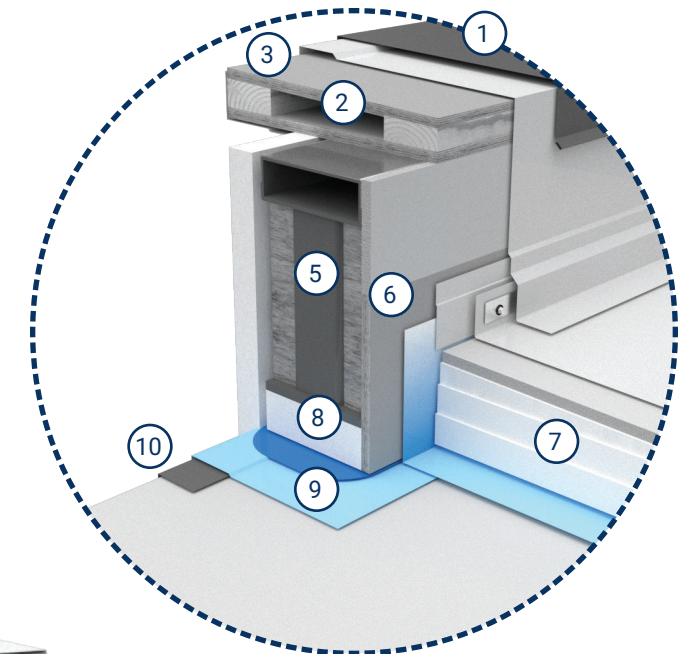
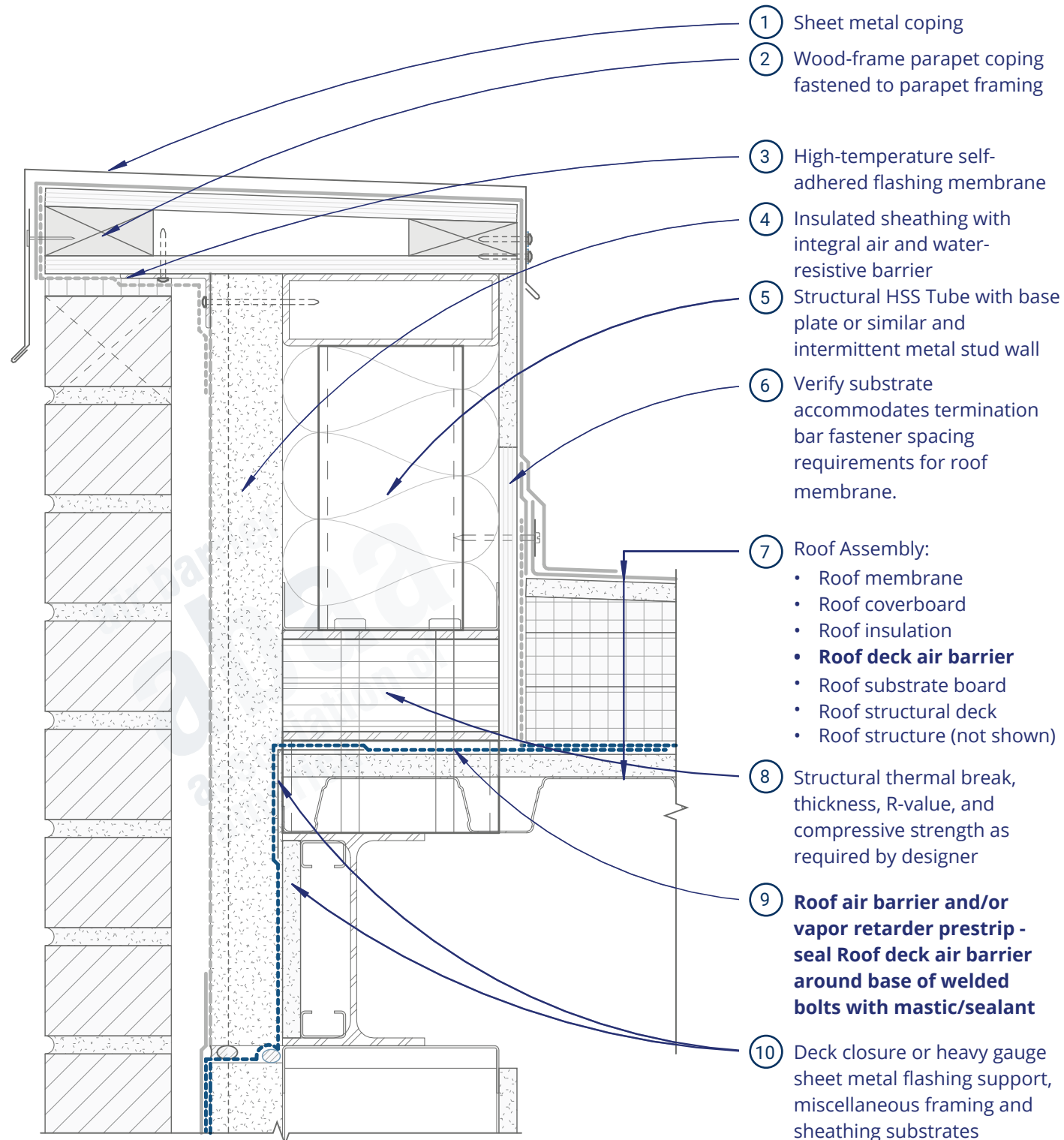

View from Roof

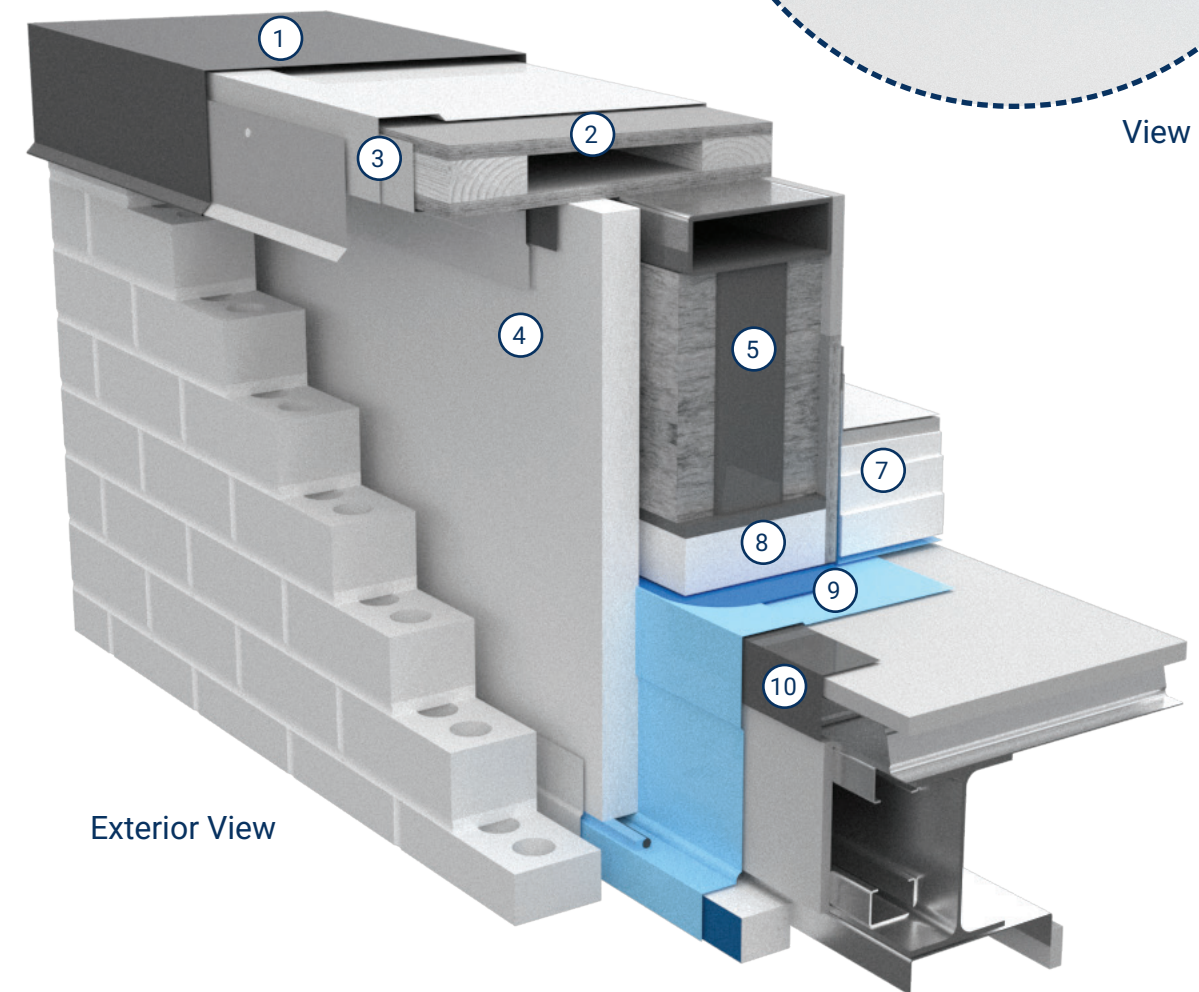

Exterior View

Insulated Sheathing Rainscreen Wall - Air Barrier Installation Prior to Parapet Extension - With Thermal Break (3D)

Parapet Details:
See General Notes sheet regarding parapet heights, condensation risk, and air and thermal continuity.

Detail RW1

Roof-to-Rising-Wall-Transition - Brick Shelf Angle With Standoff Clips (2D)

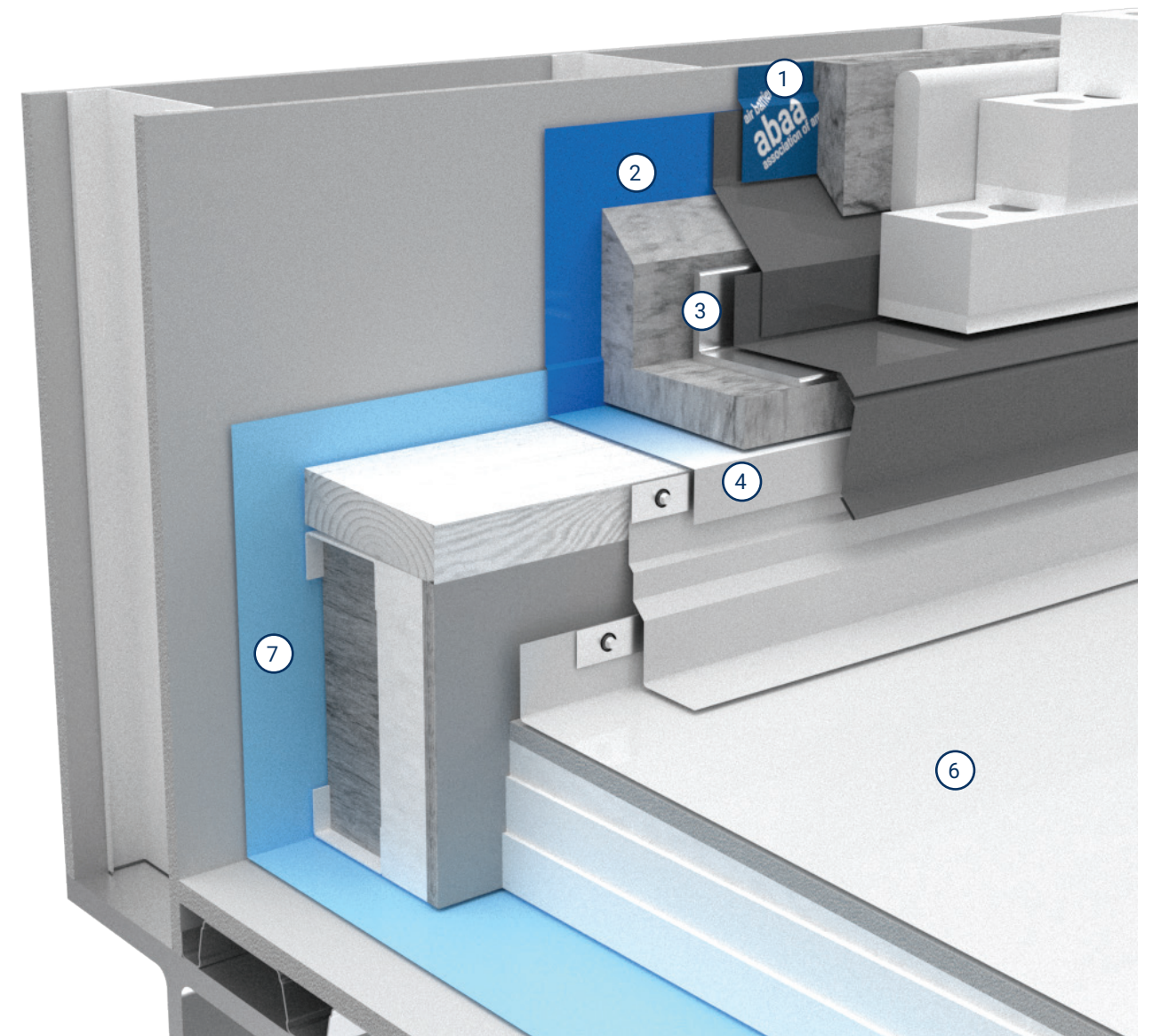
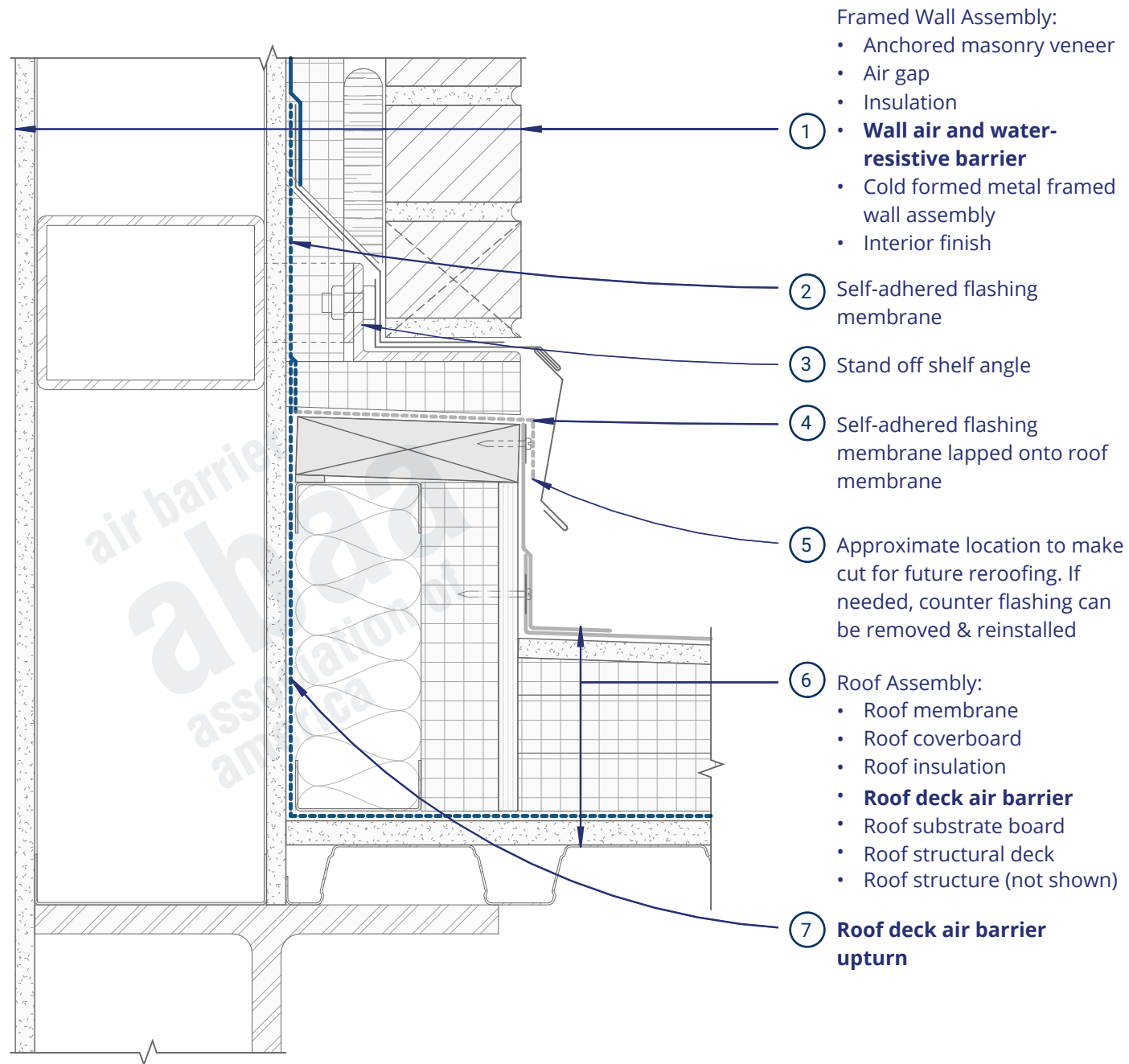

Roof-to-Rising-Wall-Transition - Brick Shelf Angle With Standoff Clips (2D)

Detail RW2

Roof-to-Rising-Wall Transition - Structural Thermal Break (2D)

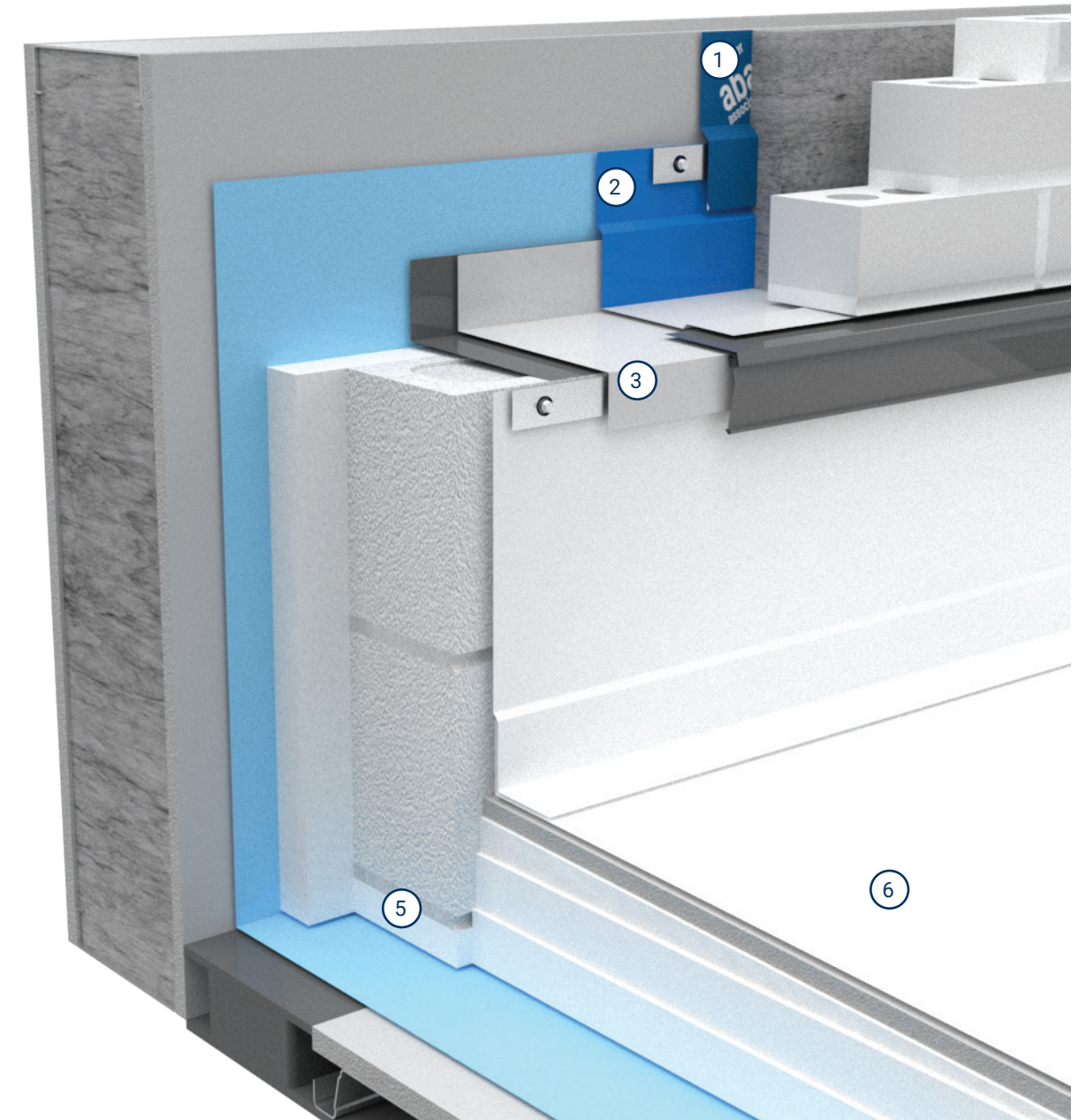
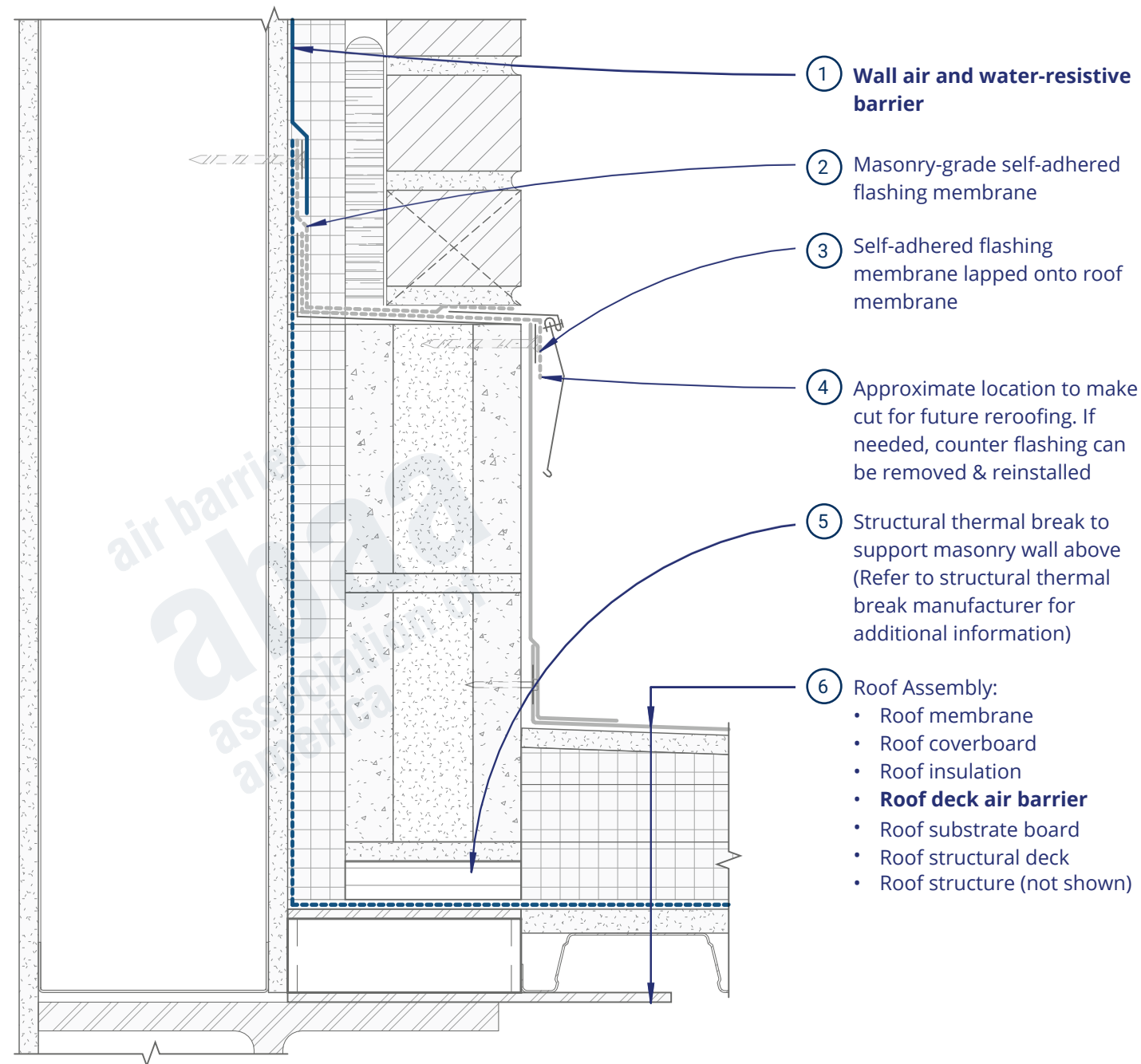

Roof-to-Rising-Wall Transition - Structural Thermal Break (3D)

Detail CL1

Roof Overhang - With Air Barrier Transition Through Metal Deck (2D)

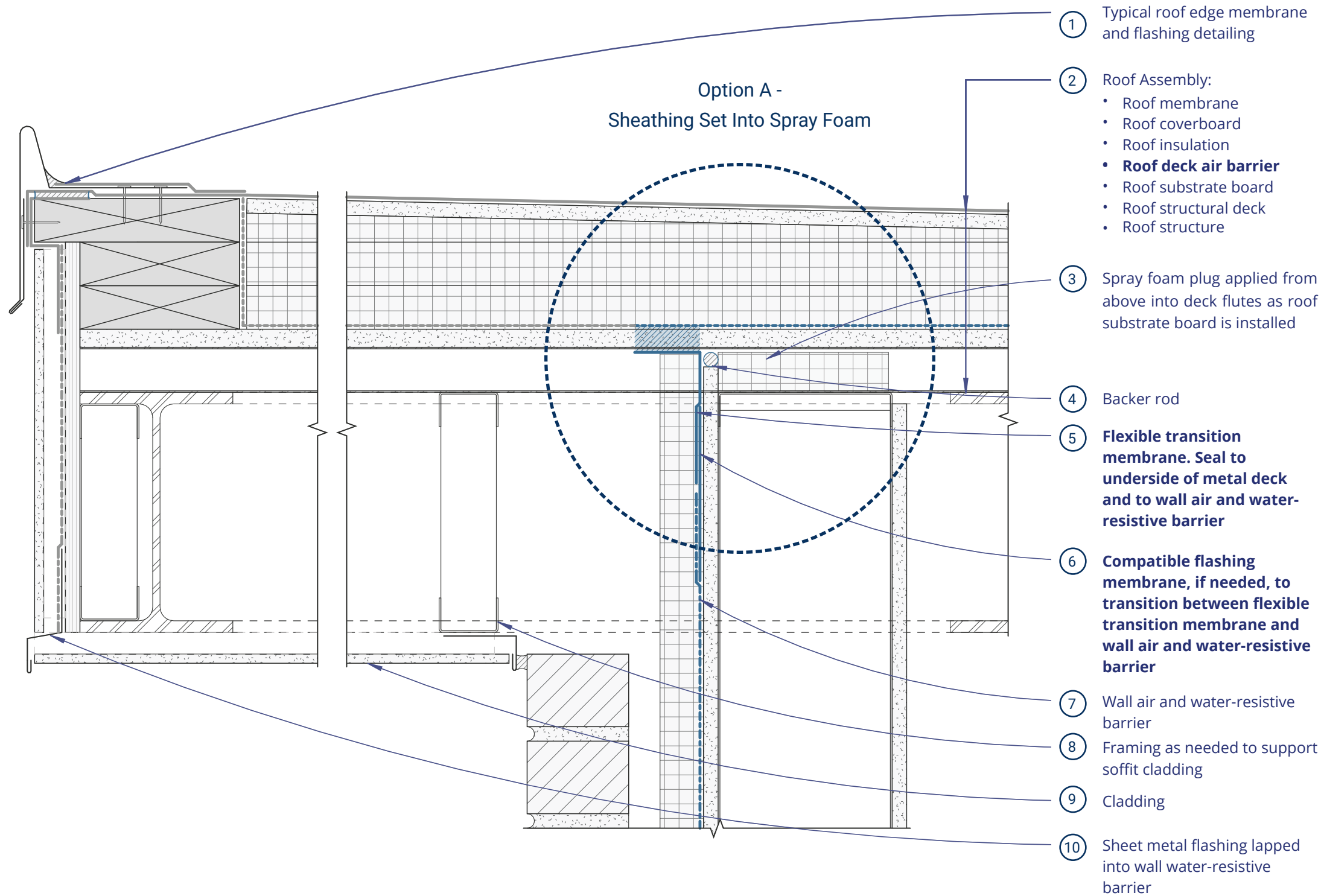

Strip of roof deck air barrier membrane, sealed from top of substrate board to sheet metal strip.

Strip of sheet metal. Seal all laps.

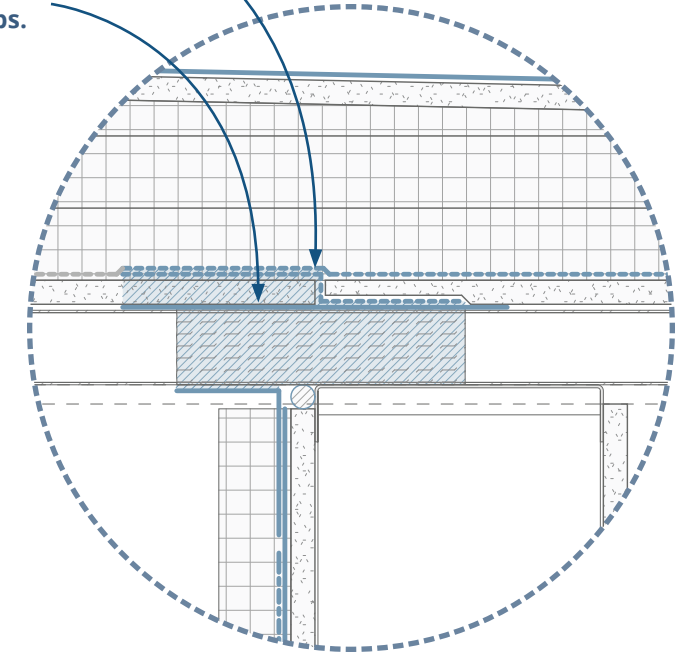

Option B - Membrane Transition at Split Sheathing

Detail CL1

Roof Overhang - With Air Barrier Transition Through Metal Deck (3D)

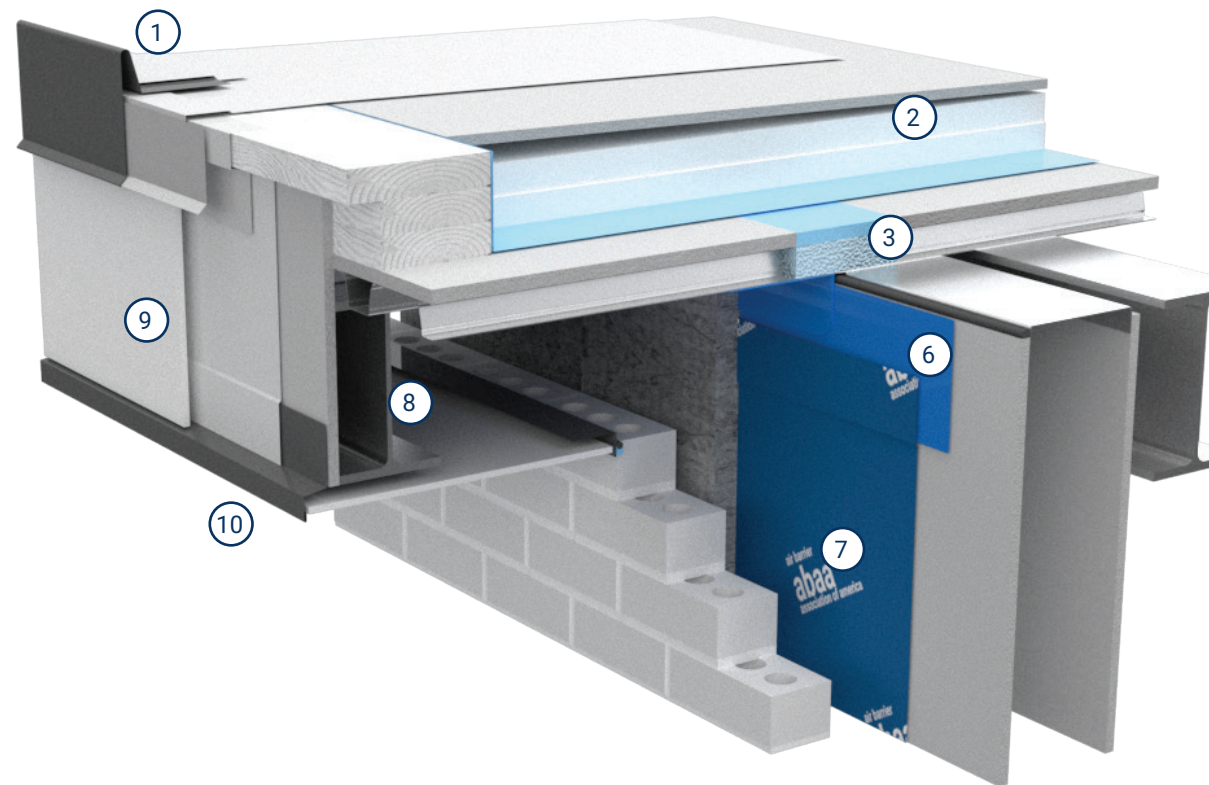
View from
Top Right

- ① Typical roof edge membrane and flashing detailing
- ② Roof Assembly:
 - Roof membrane
 - Roof coverboard
 - Roof insulation
 - **Roof deck air barrier**
 - Roof substrate board
 - Roof structural deck
 - Roof structure
- ③ Spray foam plug applied from above into deck flutes as roof substrate board is installed
- ④ Backer rod
- ⑤ **Flexible transition membrane. Seal to underside of metal deck and to wall air and water-resistant barrier**
- ⑥ **Compatible flashing membrane, if needed, to transition between flexible transition membrane and wall air and water-resistant barrier**
- ⑦ Wall air and water-resistant barrier
- ⑧ Framing as needed to support soffit cladding
- ⑨ Cladding
- ⑩ Sheet metal flashing lapped into wall water-resistant barrier

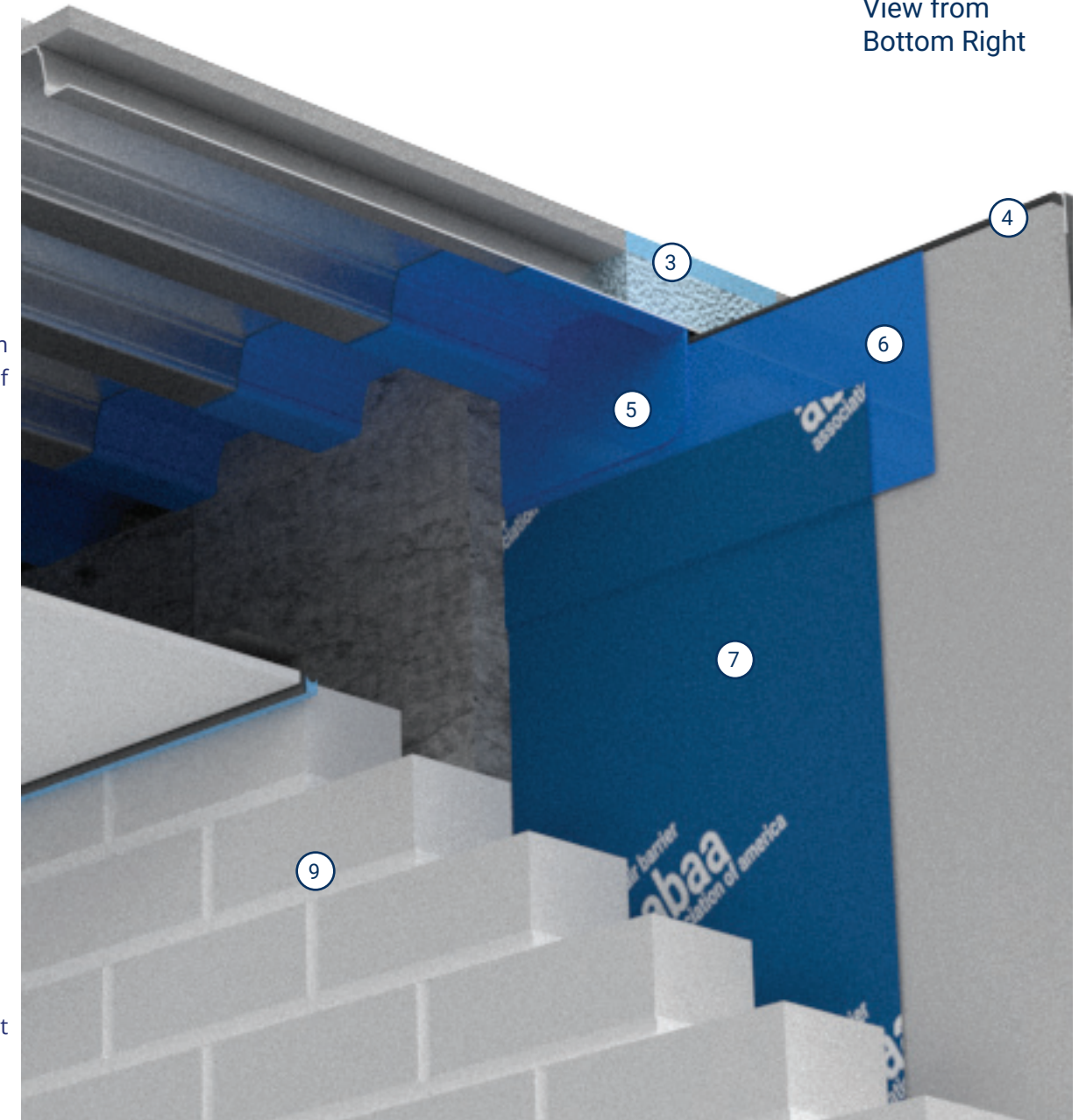
View from
Bottom Right

Detail CL2

Roof Overhang - With Structural Thermal Break (2D)

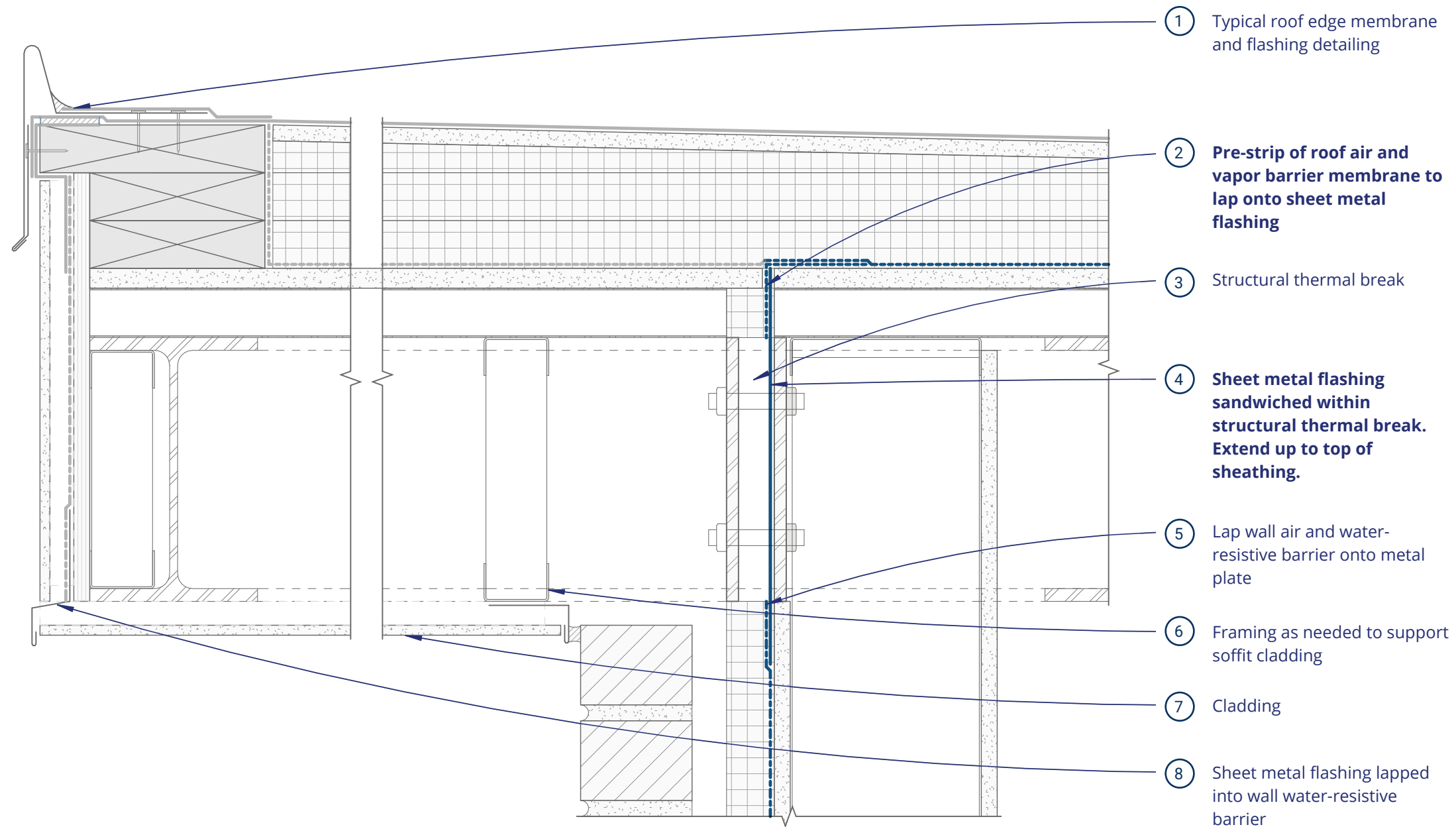

Detail CL2

Roof Overhang - With Structural Thermal Break (3D)

View from Top Right

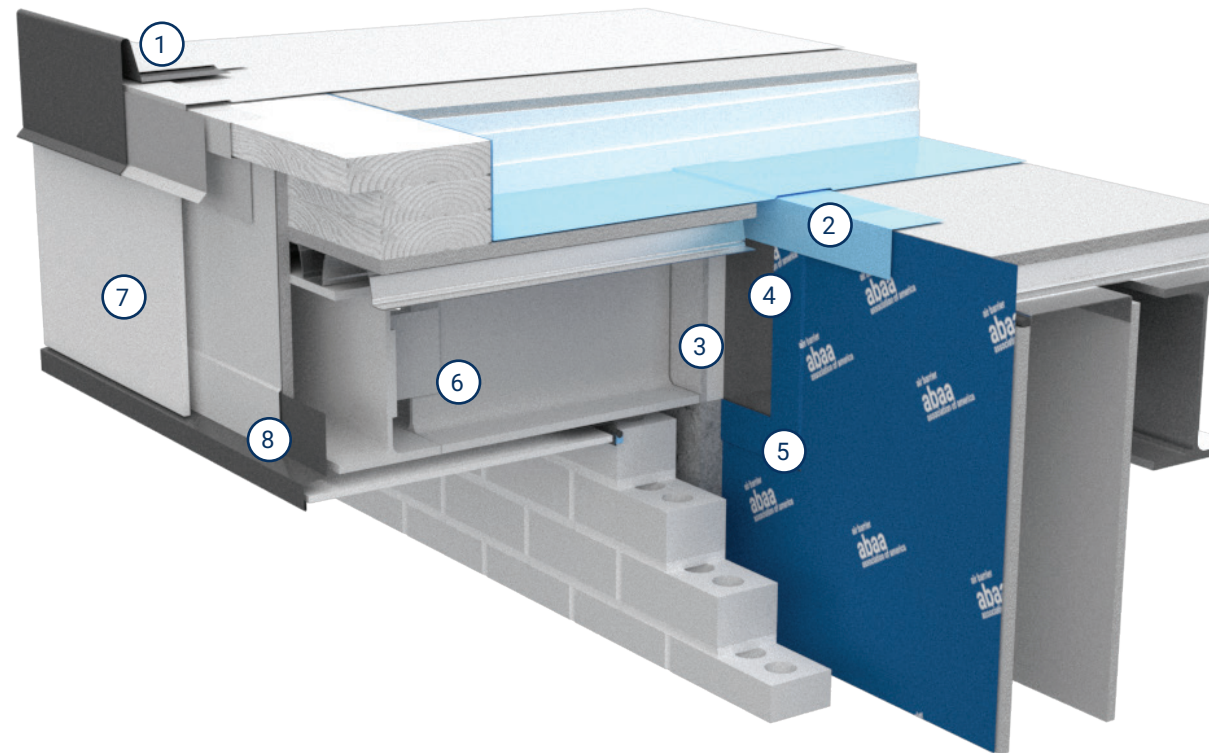

- ① Typical roof edge membrane and flashing detailing
- ② Pre-strip of roof air and vapor barrier membrane to lap onto sheet metal flashing
- ③ Structural thermal break
- ④ Sheet metal flashing sandwiched within structural thermal break. Extend up to top of sheathing.
- ⑤ Lap wall air and water-resistant barrier onto metal plate
- ⑥ Framing as needed to support soffit cladding
- ⑦ Cladding
- ⑧ Sheet metal flashing lapped into wall water-resistant barrier

View from Bottom Right



Detail CL3

Roof Overhang - With Air Barrier Wrapped Overhang (2D)

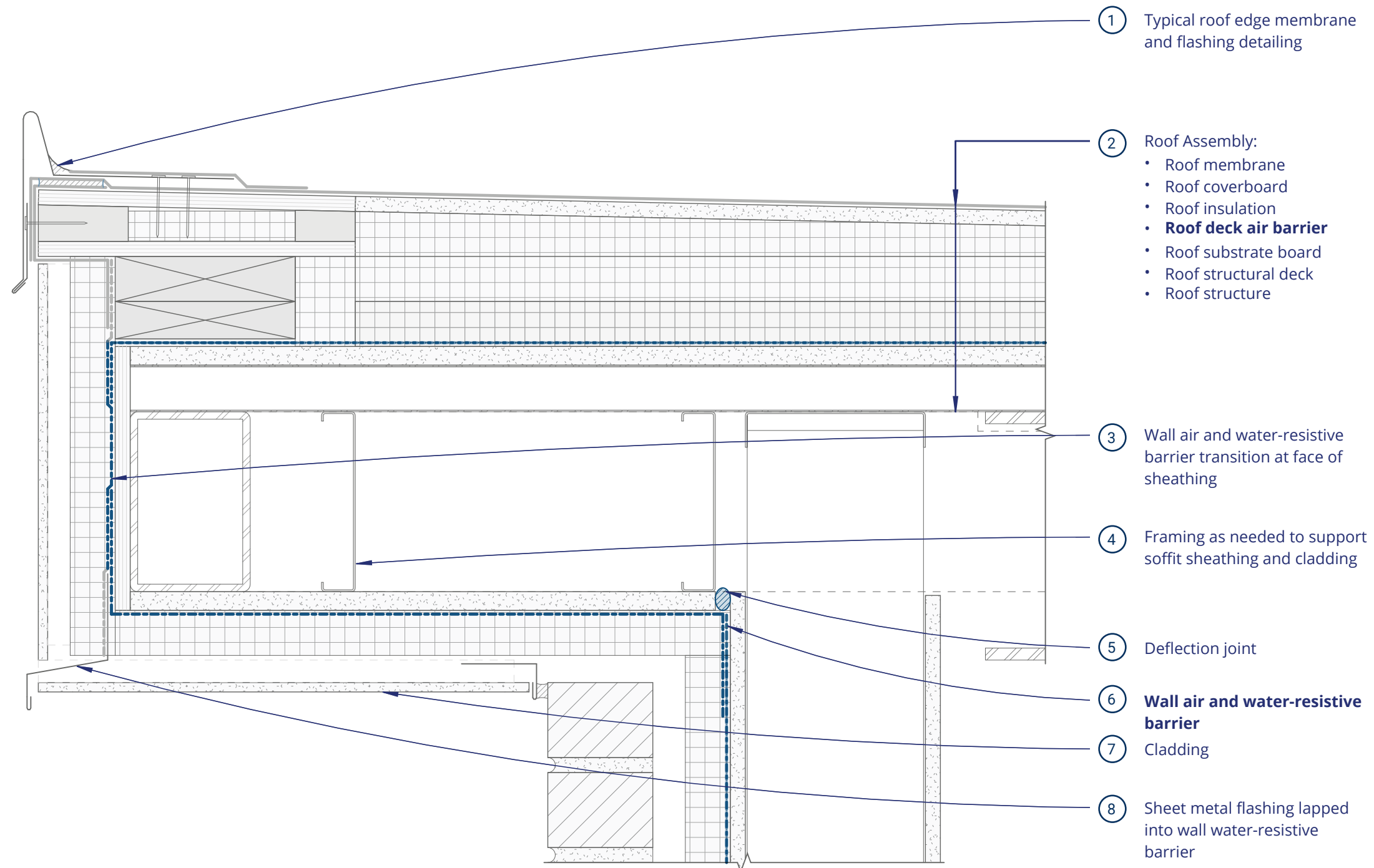

Detail CL3

Roof Overhang - With Air Barrier Wrapped Overhang (3D)

View from Top Right

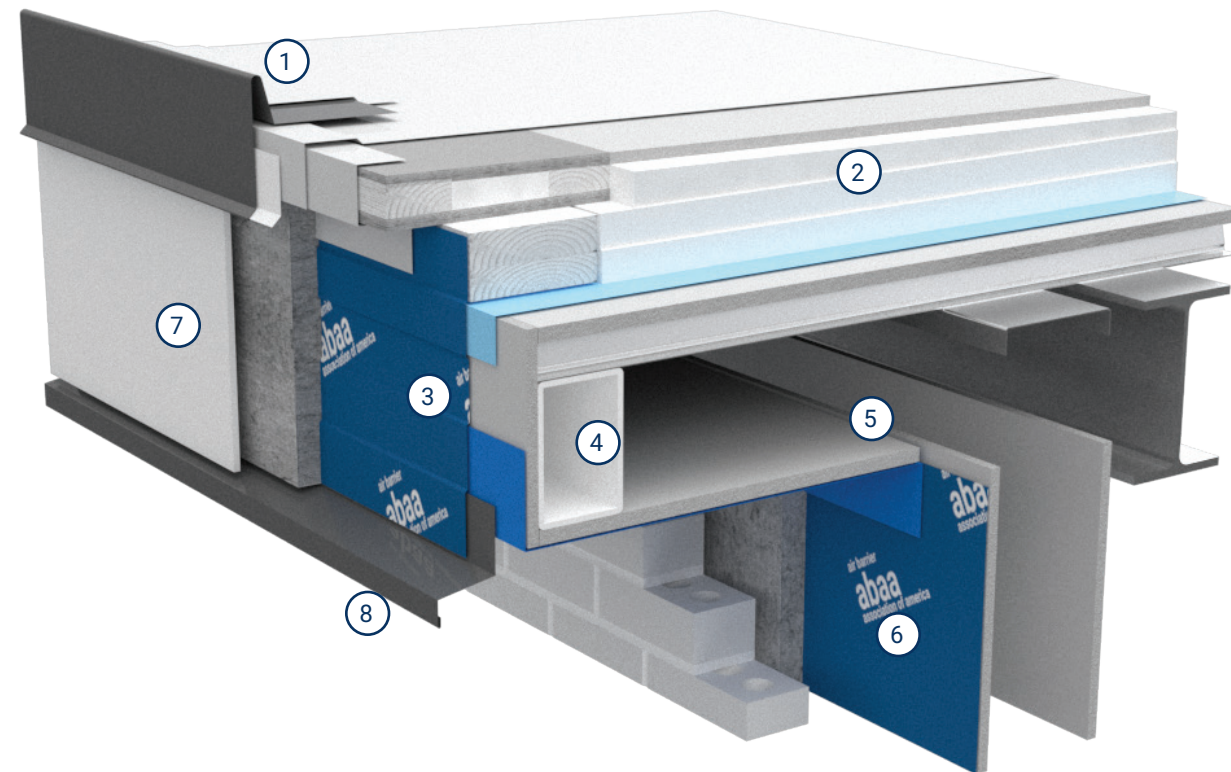

① Typical roof edge membrane and flashing detailing

② Roof Assembly:

- Roof membrane
- Roof coverboard
- Roof insulation
- **Roof deck air barrier**
- Roof substrate board
- Roof structural deck
- Roof structure

③ Wall air and water-resistive barrier transition at face of sheathing

④ Framing as needed to support soffit sheathing and cladding

⑤ Deflection joint

⑥ **Wall air and water-resistive barrier**

⑦ Cladding

⑧ Sheet metal flashing lapped into wall water-resistive barrier

View from Bottom Right

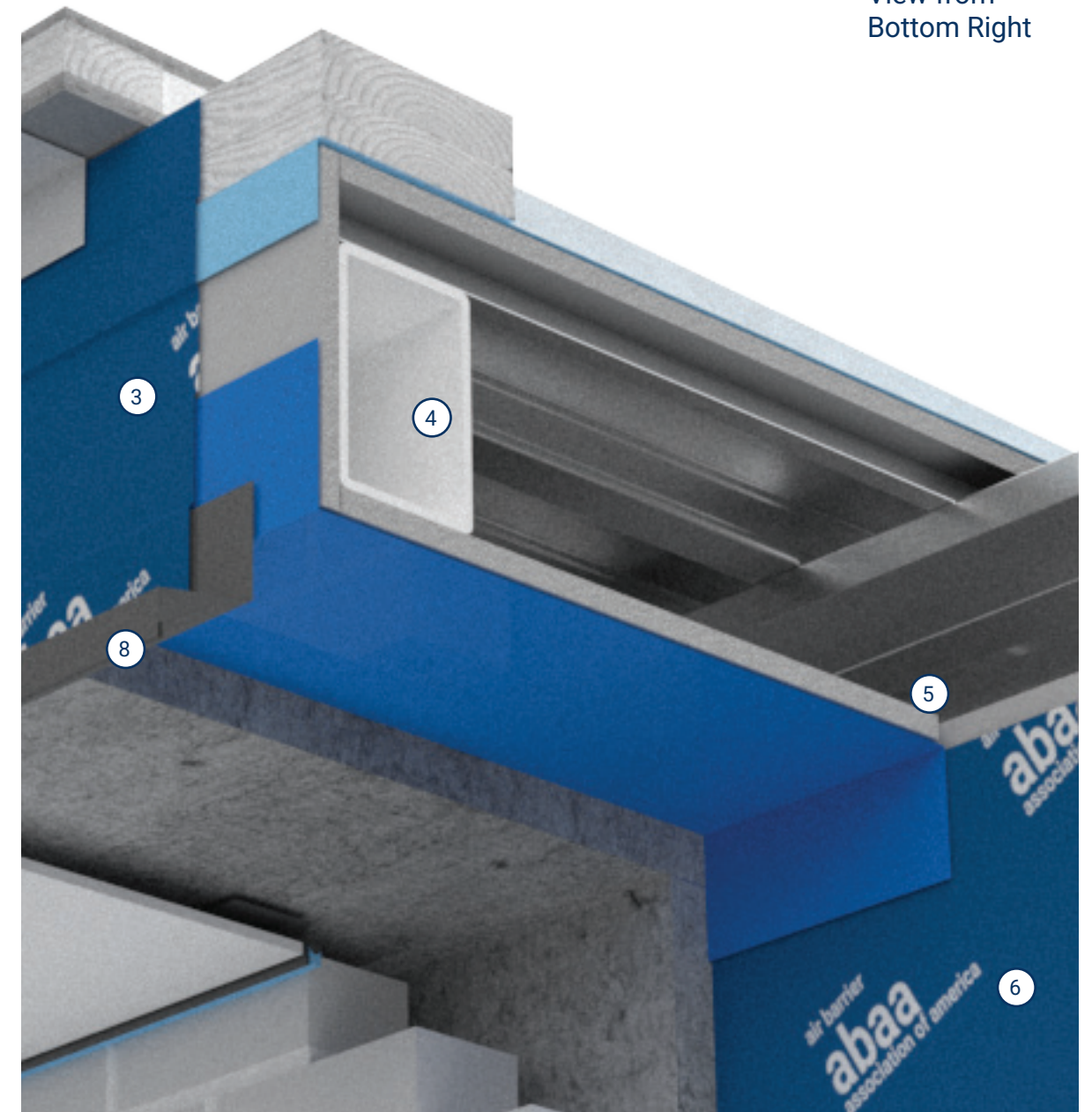

Detail IM1

Solutions for Incompatible Roof and Wall Membranes (2D)

